



Main

Range of product	Harmony XB5
Product or component type	Flush mounting kit
Accessory / separate part category	Mounting and fixing accessory
Product compatibility	ZB5RZA0 ZB5AJ ZB5AW ZB5AD.9 ZB5AA.6 ZB5AD.8 ZB5AH..3 ZB5RTA ZB5AK ZB5AD
Accessory / separate part destination	Selector switch with high bezel and high guard Illuminated push-button with high bezel and high guard

Complementary

Colour	Black
IP degree of protection	IP66 front face IEC 60529 IP69 front face IEC 60529 IP69K front face DIN 40050-9
IK degree of protection	IK03 IEC 50102
Mounting diameter	30.5 mm
Quantity per set	Set of 1
Product weight	0.007 kg

Dimensions with Flush Mounting Kit

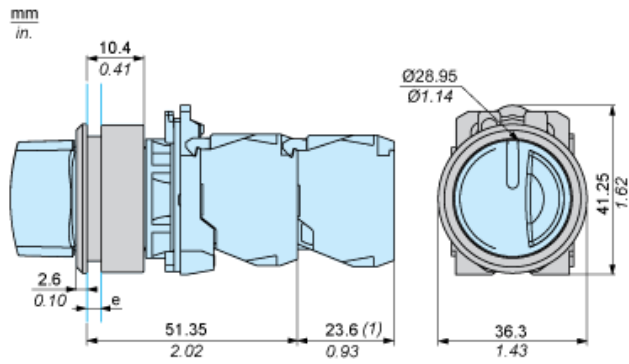

- e : Clamping thickness : 1 to 3.5 mm / 0.04 to 0.14 in.
- (1) Additional row of contacts or double contact

Panel Cut-Out and Mounting

