

# ISL32740EVAL1Z

## User's Manual: Evaluation Board

Industrial Precision

ISL32740EVAL1Z

Evaluation Board

UG119  
Rev.1.00  
Aug 24, 2017

**1. Overview**

The ISL32740EVAL1Z board enables the evaluation of the [ISL32740EIBZ](#) isolated, half-duplex RS-485 transceiver in a typical bus node application, used in isolated industrial networks.

**1.1 Features**

- Drive capability of up to 160x1/5UL-transceivers
- Isolated 3.3V to 5V DC/DC converter with regulated output

**1.2 Specifications**

This board has been configured and optimized for the following operating conditions:

- Up to 40Mbps data rate
- $V_{CC} = 3.3V$

**1.3 Related Literature**

- For a full list of related documents, visit our website
  - [ISL32740E](#) product page

**1.4 Ordering information**

Part Number	Description
ISL32740EVAL1Z	ISL32740EIBZ evaluation board

**1.5 Block Diagram**

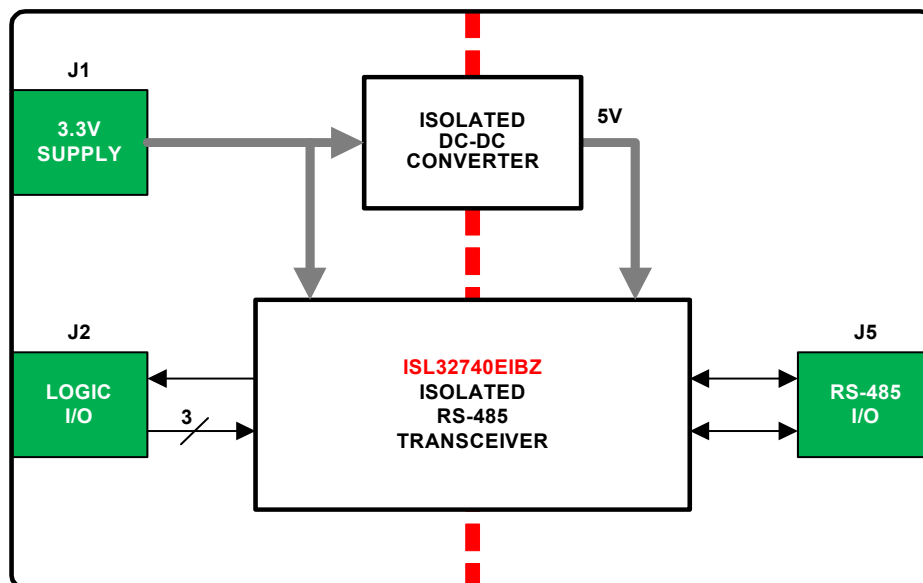

Figure 1. Block Diagram

## 2. Functional Description

The ISL32740EIBZ is an isolated, 40Mbps, half-duplex RS-485 transceiver. The device incorporates a patented refresh circuit to maintain the correct output state with respect to data input. At power-up, the bus outputs follow the truth tables shown in [Tables 1](#) and [2](#).

The DE input should be held low during power-up to prevent false drive data pulses on the bus. This is accomplished by connecting DE using a 10k $\Omega$  pull-down resistor to GND1.

This transceiver uses a differential input receiver for maximum noise immunity and common-mode rejection. Input sensitivity is  $\pm 200\text{mV}$ , as required by the RS-485 specification.

The receiver input resistance is 54k $\Omega$  minimum. The receiver includes a “fail-safe if open” function that ensures a high-level receiver output if the receiver inputs are unconnected (floating). The receiver output is tri-statable through the active low  $\overline{\text{RE}}$  input.

The RS-485 driver is a differential output device that delivers at least 2.1V across a 54 $\Omega$  purely differential load. The driver features low propagation delay skew to maximize bit width and to minimize EMI.

The driver in the ISL32740E is tri-statable through the active high DE input. The outputs of the ISL32740E driver are not slew rate limited, so faster output transition times allow data rates of at least 40Mbps.

### Important Notice:

For convenience, an isolated DC/DC converter is used to provide the power supply across the isolation barrier. Its isolation ratings however, are lower than those of the transceiver. Therefore, it must be ensured that the ground potential difference between the left side (GND1, GND2) and the right side (GND3, GND4) of the board remain below 50VAC (see [Figure 2.1 on page 4](#)).

### 2.1 Truth Tables

**Table 1. Truth Table - Receiving**

Receiving			
Inputs			Output
$\overline{\text{RE}}$	DE	A-B	RO
0	0	$V_{AB} \geq -0.05\text{V}$	1
0	0	$-0.05\text{V} > V_{AB} > -0.2\text{V}$	Undetermined
0	0	$V_{AB} \leq -0.2\text{V}$	0
0	0	Inputs Open/Shorted	1
1	1	X	High-Z
1	0	X	High-Z*

**Table 2. Truth Table - Transmitting**

Transmitting					
Inputs			Outputs		
$\overline{\text{RE}}$	DE	D	ISODE	B	A
X	1	1	1	0	1
X	1	0	1	1	0
0	0	X	0	High-Z	High-Z
1	0	X	0	High-Z*	High-Z*

Note: \*Transceiver shutdown mode.

### 3. PCB Layout Guidelines

Both supplies,  $V_{DD1}$  and  $V_{DD2}$ , must be bypassed with 100nF ceramic capacitors. These should be placed as close as possible to the supply pins for proper operation.

#### 3.1 ISL32740EVAL1Z Evaluation Board

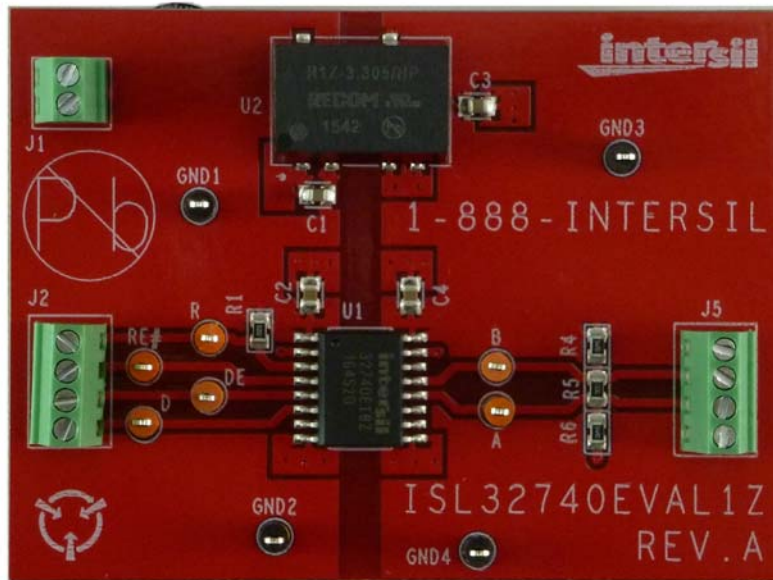

Figure 2. Top Side

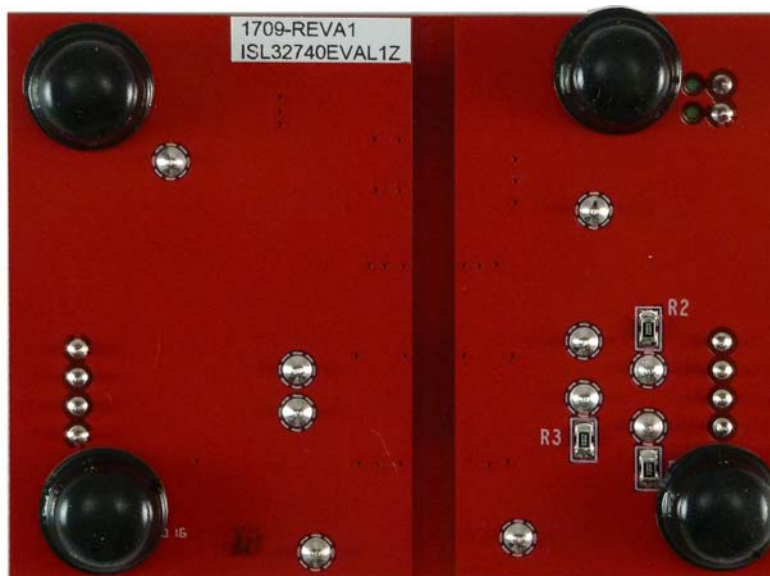

Figure 3. Bottom Side

### 3.2 ISL32740EVAL1Z Circuit Schematic

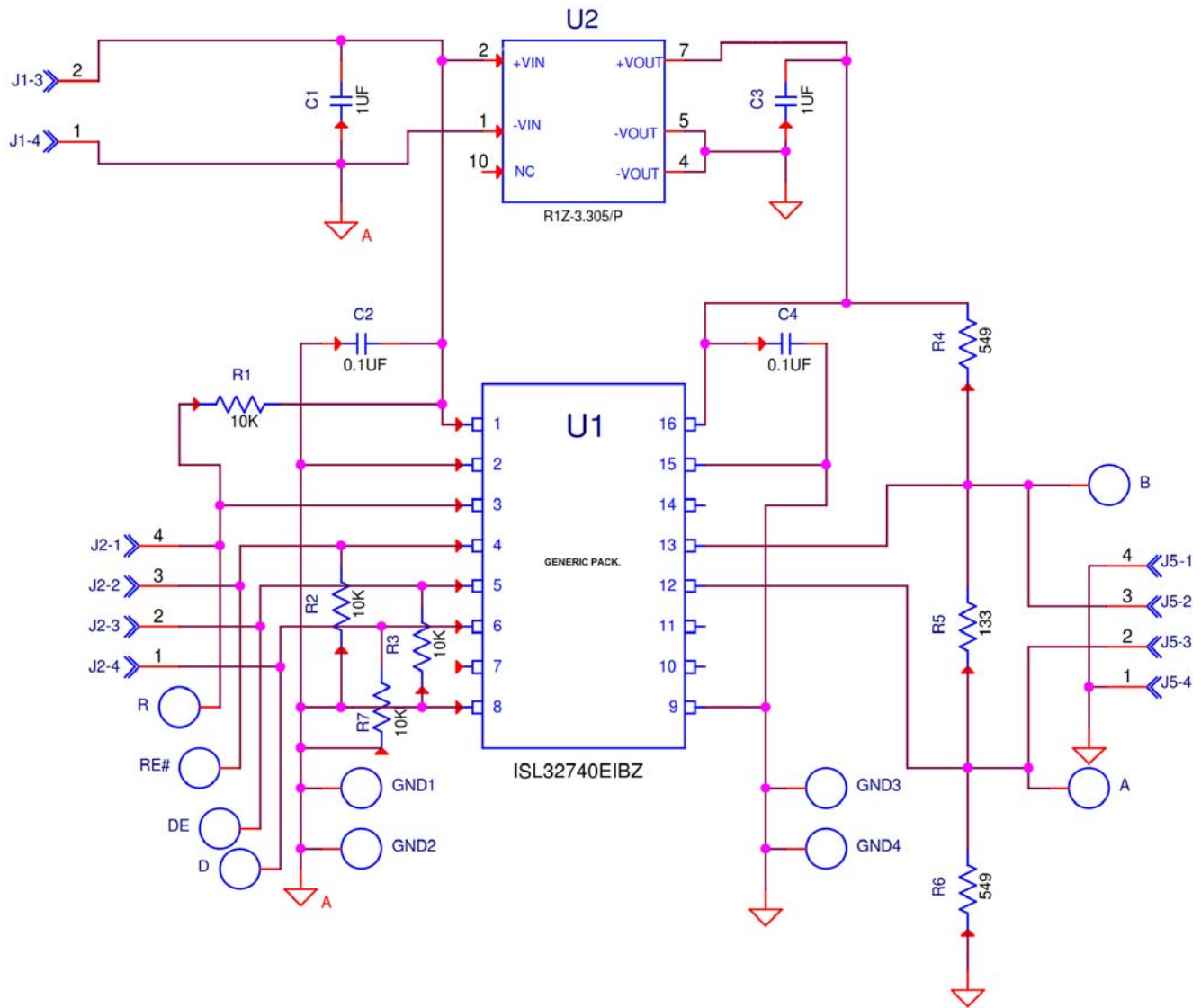

Figure 4. ISL32740EVAL1Z Schematic

### 3.3 Bill of Materials

Manufacturer Part	Qty	Reference Designator	Description	Manufacturer
ISL32740EVAL1ZREVAPCB	1		PWB-PCB, ISL32740EVAL1Z, REVA, ROHS	Imagineering Inc
ISL32740EIBZ	1	U1	ISOLATED, 40Mbps, HALF-DUPLEX RS-485 TRANSCEIVER, ROHS	Intersil
R1Z-3.305/P	1	U2	ISOLATED 3.3V-TO-5V DC/DC CONVERTER WITH REGULATED OUTPUT, ROHS	RECOM Power
CR0805-8W-1002FT (Pb-FREE)	4	R1 - R3, R7	RES, SMD, 0805, 10k, 1/8W, 1%, TF, ROHS	Venkel
RK73H2AT1330F	1	R5	RES, SMD, 0805, 133Ω, 1/8W, 1%, TF, ROHS	KOA
RC0805FR-07549RL	2	R4, R6	RES, SMD, 0805, 549Ω, 1/8W, 1%, TF, ROHS	Yageo
C0805X5R160-106KNE	2	C1, C3	CAP, SMD, 0805, 10μF, 16V, 10%, X5R, ROHS	Venkel
ECJ-2VB1E104K	2	C2, C4	CAP, SMD, 0805, 0.1μF, 25V, 10%, X7R, ROHS	Panasonic
1725656	1	J1	CONN-TERMINAL BLK, TH, 2P, 6A, 125V, 20-30AWG, 2.54mm, ROHS	Phoenix Contact
1725672	2	J2, J5	CONN-TERMINAL BLOCK, 4POS, 0.1, 26-20AWG, 63V, 6A, ROHS	Phoenix Contact
5001	4	GND1 - GND4	CONN-MINI TEST PT, VERTICAL, BLK, ROHS	Keystone
5003	6	A, B, D, R, DE, RE#	CONN-MINI TEST POINT, VERTICAL, ORG, ROHS	Keystone
S-2261	1	Place assy in bag	BAG, STATIC, 4x6, ZIPLOC, ROHS	ULINE
LABEL-DATE CODE	1	Affix to back of PCB	LABEL-DATE CODE_LINE 1: YRWK/REV#, LINE 2: BOM NAME	Intersil

### 3.4 Board Layout

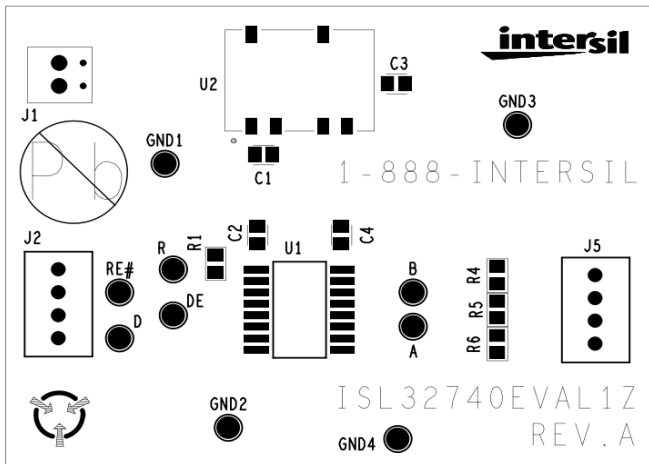

Figure 5. Silkscreen Top

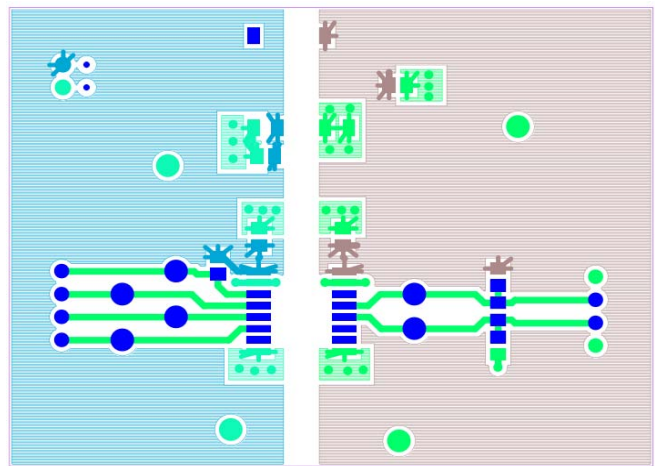

Figure 6. Top Layer

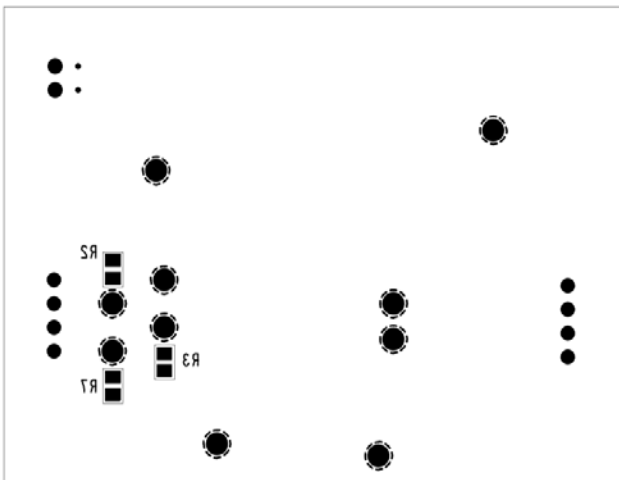

Figure 7. Silkscreen Bottom

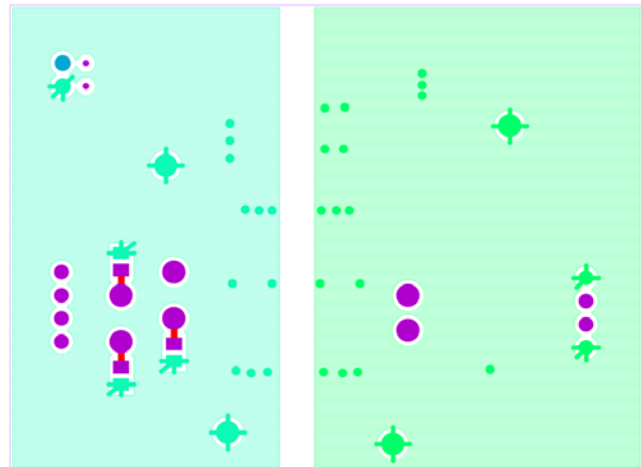

Figure 8. Bottom Layer

### 4. Performance Curves

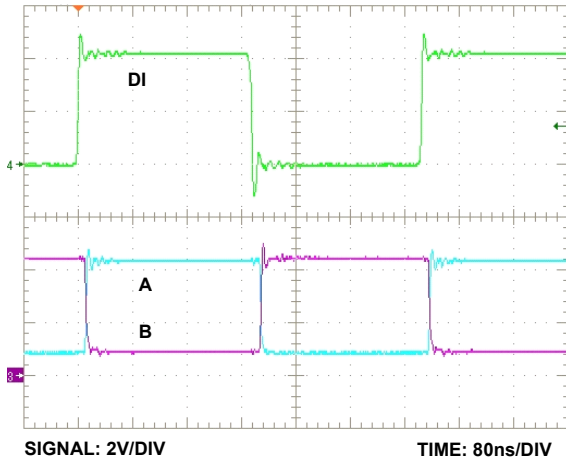

Figure 9. Transmit Mode (DR = 4Mbps)

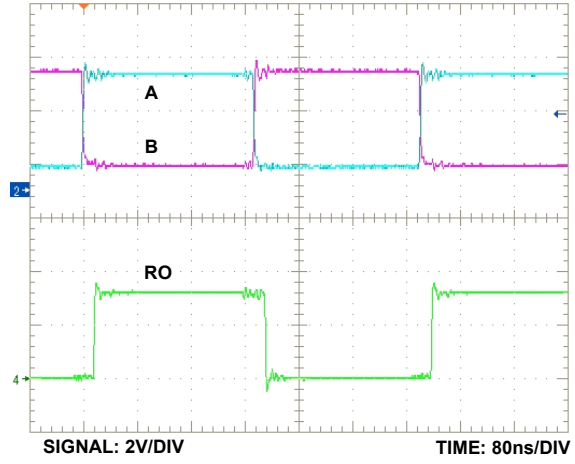

Figure 10. Receive Mode (DR = 4Mbps)

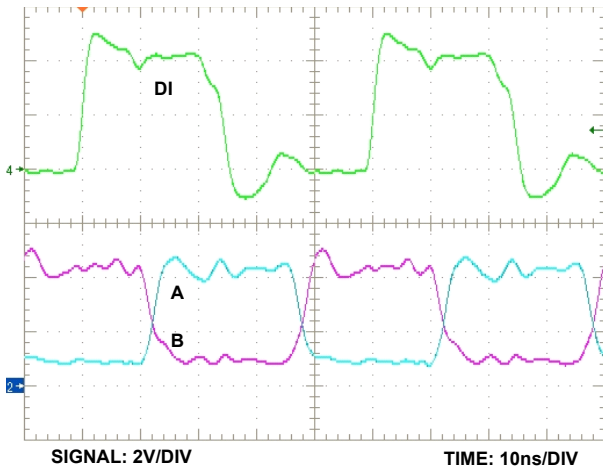

Figure 11. Transmit Mode (DR = 40Mbps)

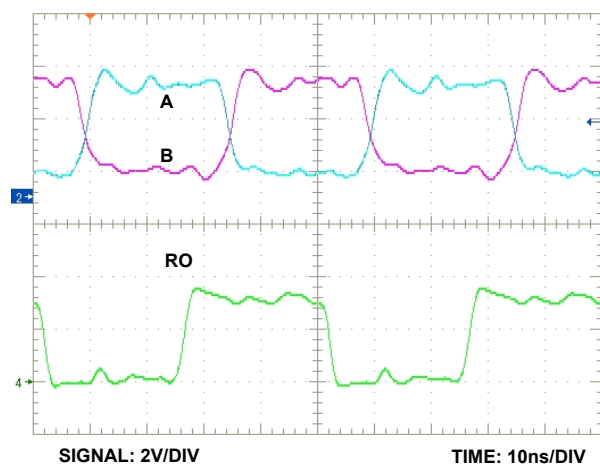

Figure 12. Receive Mode (DR = 40Mbps)



## 5. Revision History

Rev.	Date	Description
1.00	Aug 24, 2017	Updated Truth Tables on page 3.
0.00	Apr 3, 2017	Initial release

© Copyright Intersil Americas LLC 2017. All Rights Reserved.  
All trademarks and registered trademarks are the property of their respective owners.

---

*Intersil Corporation reserves the right to make changes in circuit design, software and/or specifications at any time without notice. Accordingly, the reader is cautioned to verify that the document is current before proceeding.*

---

For information regarding Intersil Corporation and its products, see [www.intersil.com](http://www.intersil.com)

ISL32740EVAL1Z