



### Main

Range of product	Zelio Relay
Product or component type	Solid state relay
Provided equipment	Thermal pad
Device short name	SSP1
Mounting support	Panel
Network number of phases	1 phase
Contacts type and composition	1 NO
[In] rated current	125 A
Solid state output type	Zero voltage switching SCR output

### Complementary

[Uc] control circuit voltage	4...32 V DC
Minimum switching voltage	4 V DC turn-on
Maximum switching voltage	1 V DC turn-off
Response time	0.5 cycle turn-on 0.5 cycle turn-off
Input current limits	7...12 mA
Output voltage	48...660 V AC
Load current	0.15...125 A
Absolute maximum voltage	1200 V
Surge current	<= 1750 A for 16.6 ms
Maximum I <sup>2</sup> t for fusing	12709 A <sup>2</sup> .s for 8.33 ms at 60 Hz half cycle 13950 A <sup>2</sup> .s for 10 ms at 50 Hz half cycle
Protection device type	Type 1 - 80 A miniature circuit breaker (MCB) - curve B Type 2 - 63 A miniature circuit breaker (MCB) - curve B
Leakage current	<= 1 mA off-state
Voltage drop	1.15 V on-state

Disclaimer: This documentation is not intended as a substitute for and is not to be used for determining suitability or reliability of these products for specific user applications

DV/Dt	500 V/ $\mu$ s off-state at maximum voltage
Cos phi	0.5 with maximum load
Motor power hp	2 hp 120 V AC 5 hp 240 V AC 10 hp 480 V AC
Insulation resistance	1000 MOhm at 500 V DC
Capacitance unbalance	8 pF for input/output
Dielectric strength	4 kV AC for input/output 4 kV AC for input or output to case
[Uimp] rated impulse withstand voltage	6 kV output to case 6 kV input to output
Tightening torque	1.5...1.7 N.m for input 2...2.2 N.m for output
Connections - terminals	Forked type tag connectors : 9.2 x 4 mm for input Ring lugs : 9.2 x 4 mm for input Forked type tag connectors : 11.7 x 4.5 mm for output Ring lugs : 11.7 x 4.5 mm for output Screw terminals : 0.2...3.3 mm <sup>2</sup> , (AWG 24...AWG 12) with cable end for input Screw terminals : 0.5...5.26 mm <sup>2</sup> , (AWG 20...AWG 10) with cable end for output Screw terminals : 0.2...3.3 mm <sup>2</sup> , (AWG 24...AWG 12) without cable end for input Screw terminals : 0.5...8.26 mm <sup>2</sup> , (AWG 20...AWG 8) without cable end for output
Thermal resistance	0.22 °C/W junction to case
Thermal impedance	0.48 °C-in <sup>2</sup> /W at 25 psi
Local signalling	LED, green for input
IP degree of protection	IP20
Safety reliability data	B10d = 1731395 MTTFd = 1875.9 years
Product weight	89.2 g

## Environment

Ambient air temperature for operation	-40...80 °C
Ambient air temperature for storage	-40...125 °C
Pollution degree	2
Overvoltage category	III
Product certifications	CE RoHS EAC REACH UL CSA
Marking	UL CSA EAC CE
Standards	EN/IEC 60950-1 UL 508 CSA C22.2 No 14-13 EN/IEC 62314

## Offer Sustainability

Sustainable offer status	Green Premium product
RoHS (date code: YYWW)	Compliant - since 1522 - Schneider Electric declaration of conformity <a href="#">Schneider Electric declaration of conformity</a>
REACH	Reference not containing SVHC above the threshold <a href="#">Reference not containing SVHC above the threshold</a>
Product environmental profile	Available <a href="#">Product environmental</a>
Product end of life instructions	Available <a href="#">End of life manual</a>

Dimensions

mm  
in.

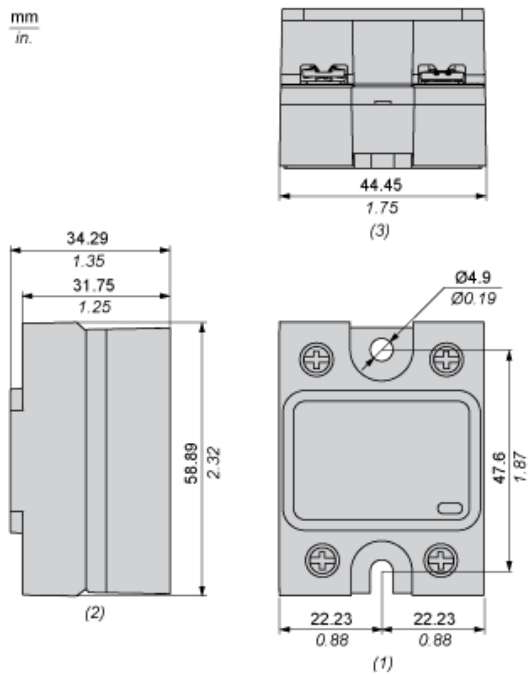

- (1) Front view
- (2) Side view
- (3) Bottom view

Derating Curves

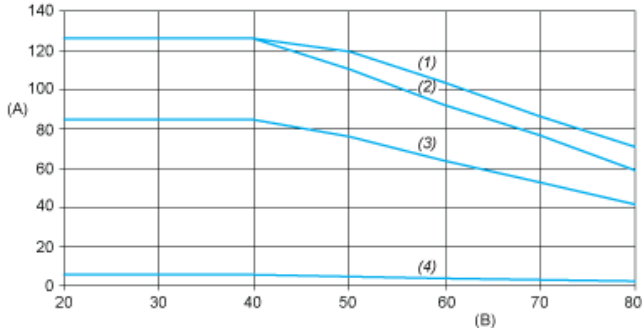

- A : Load Current (Arms)
- B : Ambient Temperature (°C)
- (1) For Heatsink SSRHP02
- (2) For Heatsink SSRHP05
- (3) For Heatsink SSRHP07
- (4) No Heatsink