

New!

Lamina BL-4000 Optics - Preliminary Data

Lamina LED Light Sources

As the market leader in the development and manufacture of super-bright LED arrays, Lamina brings solid state lighting to applications which until now were only possible with traditional lighting sources.

Lamina's LED arrays are manufactured by combining high brightness LEDs from industry-leading LED manufacturers with Lamina's proprietary packaging technology, multilayer Low Temperature Co-Fired Ceramic on Metal (LTCC-M). LTCC-M is a breakthrough in thermal performance for LED packaging technology, a key factor in determining LED life and reliability. Unmatched thermal performance coupled with package interconnectivity allows Lamina to densely cluster multiple LEDs to achieve exceptionally high luminous intensity in very small footprints. Lamina's LED light sources are available in white, RGB and monochrome, from 1W to 100W, and also in custom packages up to 1000W.

Lamina LED Light sources provide:

- HIGH LUMINOUS FLUX IN SMALL FOOTPRINT
- SUPERIOR THERMAL PERFORMANCE FOR IMPROVED RELIABILITY
- LONG LIFE AND HIGH LUMEN MAINTENANCE
- SUSTAINABLE DESIGN – RoHS COMPLIANT
- CUSTOM SIZES AND SHAPES AVAILABLE

BL-4000 Optics – Preliminary Data

Lamina now offers optics with narrow, medium and wide beam distributions designed for the BL-4000 product family. Lamina, working with Fraen Corporation, has developed optics and optic holders based on Fraen's popular FHS series. BL-4000 optics are designed to produce homogeneous beam distributions with high collection efficiencies. The optic holders are designed to attach to Lamina's EZConnect board.

Lamina BL-4000 Optic advantages:

- NARROW, MEDIUM AND WIDE BEAM DISTRIBUTIONS
- HIGH EFFICIENCY – UP TO 90%
- EASY ATTACHMENT OF OPTIC HOLDER TO EZCONNECT BOARD
- DURABILITY
- EXCELLENT LONG-TERM STABILITY



LAMINA LED LIGHT SOURCE TYPICAL APPLICATIONS

ARCHITECTURAL LIGHTING

- DECORATIVE AND ACCENT
- COVE AND UNDER-SHELF
- GARDEN AND PATHWAY
- STEP LIGHTS

ARCHITAINMENT

LCD BACKLIGHTING

SIGNAGE & CHANNEL LETTERS

SIGNALS

- AIRFIELD TAXIWAY
- TRAFFIC
- SECURITY
- BEACONS
- RAIL

MACHINE VISION





MEDICAL

To see how you can realize all these design benefits, to request a sample, or to speak with an engineer about your design, contact Lamina at 800.808.5822 or 609.265.1401 or visit www.laminaceramics.com.

General Characteristics	
Lens Material	Optical Grade PMMA
Holder Material	PC ABS
Operating Temperature range	-40°C / +80°C
Storage Temperature range	-40°C / +80°C

Optical Performance– Preliminary Data

The BL-4000 typical beam distributions are shown below.

BL-4000 RGB		Typical total beam divergence (deg) (1)			
Lens Part Number	Type of lens	Red Only	Green Only	Blue Only	RGB
					
FHS-HNB1-LC01-H	Narrow beam	N/A	N/A	N/A	N/A
FHS-HMB1-LC01-H	Medium beam	25	25	25	25
FHS-HWB1-LC01-H	Wide beam	40	40	40	40

BL-4000 White		Typical total beam divergence (deg) (1)
Lens Part Number	Type of lens	
FHS-HNB1-LC01-H	Narrow beam	10
FHS-HMB1-LC01-H	Medium beam	30
FHS-HWB1-LC01-H	Wide beam	45

1. The typical total divergence is the full angle measured where the luminous intensity is half of the peak value.

Dimensional Specifications

Lamina's BL-4000 optics are sold unassembled to an optic holder. The optic is attached to the holder via mechanical clips as well as with heat staking. Heat staking ensures the optics are firmly attached to the holder, and prevents optic movement in vibration sensitive applications.

The outside mechanical dimensions of all the Lambertian lenses (Narrow, Medium and Wide beam) are the same. The top of the lens, however, is different and can be identified by the images on the following page:

To see how you can realize all these design benefits, to request a sample, or to speak with an engineer about your design, contact Lamina at 800.808.5822 or 609.265.1401 or visit www.laminaceramics.com.

Top Views of Optics

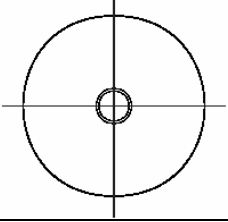
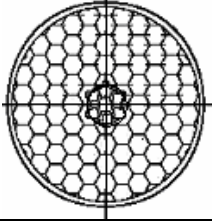
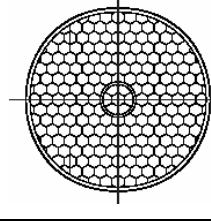
Narrow Beam lens: FHS-HNB1-LC01-H	Medium Beam lens: FHS-HMB1-LC01-H	Wide Beam lens: FHS-HWB1-LC01-H
		
Flat surface	2.6mm hexagonal shaped microlens array	1.7mm hexagonal shaped microlens array

Mechanical Dimensions

Mechanical Dimensions

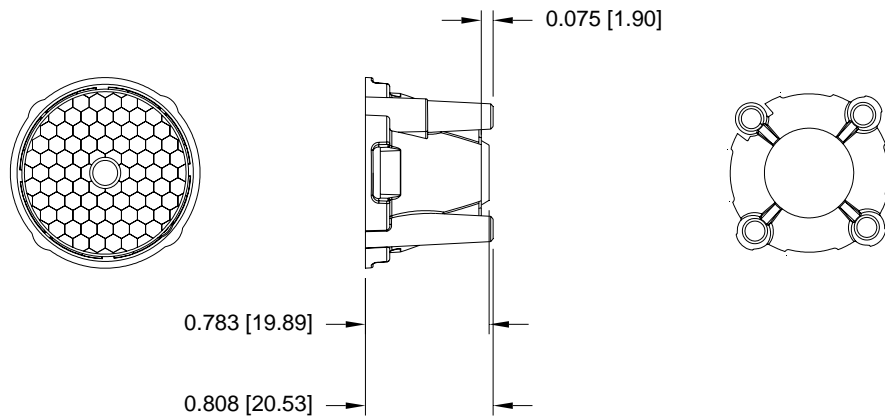

Lens and Holder Assembly

Optic, Optic Holder, BL-4000 RGB+ Light source attached to EZConnect Board and wiring harness



Assembled BL-4000 Module



Note: Optic is sold attached to the optic holder.

Assembly

The BL-4000 optic holders are designed to be inserted into the four corner holes in Lamina's EZConnect board. The EZConnect board is designed to align the optic to the center of the light source and allow the optic to rest on the light source surface.

Attachment of the optic holder to the EZConnect board is performed using epoxy or a silicone based adhesive. Recommended epoxy is Loc-Tite OM-50/81501 two-part, room temperature curing epoxy, or an equivalent. Adhesive should be applied to the optic holder legs and / or to the heat sink surface, below the holes in the EZConnect board. Care should be taken to prevent adhesive from coming in contact with the clear optic surfaces. In addition, to prevent damage to the LED light source, avoid contact or pressure on the light source domes.

Please visit Lamina's website, www.LaminaCeramics.com, for more information on Lamina's LED light sources and Lamina's worldwide distribution network.

Lamina Ceramics
120 Hancock Lane
Westampton, NJ 08060

Specifications subject to change without notice.
©2005 Lamina Ceramics, Inc.
REV. 07.25.05

To see how you can realize all these design benefits, to request a sample, or to speak with an engineer about your design, contact Lamina at 800.808.5822 or 609.265.1401 or visit www.laminaceramics.com.