

ACT20P ACT20P-UI-AO-DO-LP-S

Weidmüller Interface GmbH & Co. KG
 Klingenbergstraße 16
 D-32758 Detmold
 Germany
 Fon: +49 5231 1429-0
 Fax: +49 5231 14292083
 www.weidmueller.com



ACT20P: The flexible solution

- Precise and highly functional signal converters
- Simple configuration via display (Pro DCDC II), FDT/DTM software or DIP switch
- Release levers simplify handling
- More space in the control cabinet, from 12.5 mm wide for two channels

General ordering data

Type	ACT20P-UI-AO-DO-LP-S
Order No.	1453210000
Version	ACT20P, Signal converter/insulator, Limit value monitoring, Input: temperature, R, U, I, Output current loop powered, Screw connection
GTIN (EAN)	4050118259605
Qty.	1 pc(s).

ACT20P
ACT20P-UI-AO-DO-LP-S

Weidmüller Interface GmbH & Co. KG
 Klingenbergstraße 16
 D-32758 Detmold
 Germany
 Fon: +49 5231 1429-0
 Fax: +49 5231 14292083
 www.weidmueller.com

Technical data**Dimensions and weights**

Width	12.5 mm	Width (inches)	0.492 inch
Height	119.2 mm	Height (inches)	4.693 inch
Depth	113.6 mm	Depth (inches)	4.472 inch
Net weight	80 g		

Temperatures

Humidity	10...90 % (no condensation)	Operating temperature	-20 °C...70 °C
Ambient temperature	-20 °C...+70 °C	Storage temperature	-20 °C...70 °C

Input

Number of inputs	1	Type	Universal signal isolator / signal amplifier, thermocouple, RTD
Sensor	PT100 / 2-/3-/4-wire, PT1000/2-/3-/4-wire, PT200, N120, Thermocouples: B, E, J, K, L, N, R, S, T, U, Potentiometer	Sensor supply	0.1 mA / 0.05 mA (depending on measuring range) @ RTD cable
Influence of the sensor cable resistance		Input voltage	configurable, ± 300 V DC (min. measurement range 100 V), 0...300 V AC (min. measurement range 100 V)
Input resistance, voltage	5 Ω @ RTD- Kabel	Input current	configurable, ± 5 A DC (min. measurement range 0.5 A)
Input resistance, current	2 MΩ, > 10 MΩ	Input measurement range	PT100 -200...+850 °C, Thermocouple type J -100...+1200°C, Thermocouple type K -200...+1370°C, customization
Cable-length compensation	40 Ω	Resistance	0... 12 kΩ, 0... 1k5 Ω, 0... 750 Ω
Potentiometer	< ±0.002 Ω per cable resistance Ω		
	1.2...500 kΩ		

Output

Type	Output-loop powered	Number of outputs	1
Output signal limit	Harmonics: <10 mV (peak to peak)	Output current	4...20 mA, 20...4 mA, Current loop
cold junction compensation	±1°C (-20°C...60°C)	load impedance current	typ. 700 Ω @ 24 V DC
Supply voltage	via output current loop		

General data

Accuracy	< 0.1 % of measuring range	Cold-junction compensation error	±1.0°C @ -20° C - 65°C
Configuration	With FDT/DTM software	Galvanic isolation	2-way isolator, between input/output
Mounting rail	TS 35	Step response time	450 ms
Supply voltage	Output loop powered, (10...45 V)	Temperature coefficient	< 0.02 °C of measuring range / °C

Creation date November 7, 2017 5:36:17 PM CET

Catalogue status 20.10.2017 / We reserve the right to make technical changes.

2

ACT20P
ACT20P-UI-AO-DO-LP-S

Weidmüller Interface GmbH & Co. KG
 Klingenbergstraße 16
 D-32758 Detmold
 Germany
 Fon: +49 5231 1429-0
 Fax: +49 5231 14292083
 www.weidmueller.com

Technical data**Insulation coordination**

Galvanic isolation	2-way isolator, between input/output	Impulse withstand voltage	4 kV (1.2/50 µs)
Insulation voltage	3.51 kV between input and output	Pollution severity	2
Rated voltage	300 V _{eff}	Standards	DIN EN 61326-1, DIN EN 61010-1
Surge voltage category	III		

Output (digital)

Type	Transistor, open collector	Rated switching current	20 mA
Rated switching voltage	≤ 30 V DC		

Connection data

Type of connection	Screw connection	Tightening torque, min.	0.4 Nm
Tightening torque, max.	0.6 Nm	Clamping range, rated connection	2.5 mm ²
Clamping range, rated connection, min.	0.5 mm ²	Clamping range, rated connection, max.	2.5 mm ²
Wire connection cross section AWG, min.	AWG 30	Wire connection cross section AWG, max.	AWG 14

Classifications

ETIM 5.0	EC002653	ETIM 6.0	EC002653
eClass 6.2	27-21-01-20	eClass 7.1	27-21-01-20
eClass 8.1	27-21-01-20	eClass 9.0	27-21-01-20
eClass 9.1	27-21-01-90		

Product information

Descriptive text ordering data	CBX200 USB configuration adapter - 8978580000
--------------------------------	---

Approvals

Approvals



ROHS Conform

Downloads

Approval/Certificate/Document of Conformity	Declaration of Conformity
Brochure/Catalogue	CAT 4.1 ELECTR 16/17 EN
Engineering Data	EPLAN, WSCAD, Zuken E3.S
Software	WI-Manager, DTM-Library for online installation
User Documentation	Instruction sheet

**ACT20P
ACT20P-UI-AO-DO-LP-S**

Weidmüller Interface GmbH & Co. KG
 Klingenbergstraße 16
 D-32758 Detmold
 Germany
 Fon: +49 5231 1429-0
 Fax: +49 5231 14292083
 www.weidmueller.com

Drawings

Wiring diagram

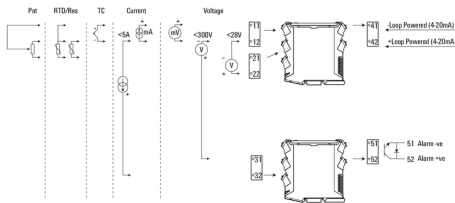

Dimensioned drawing

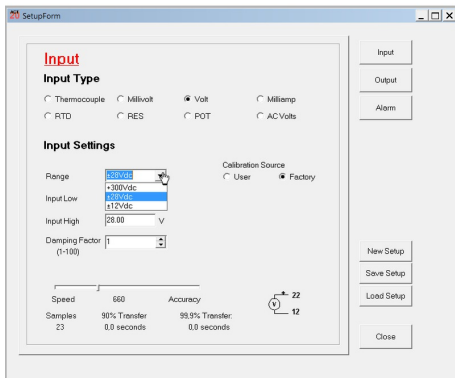
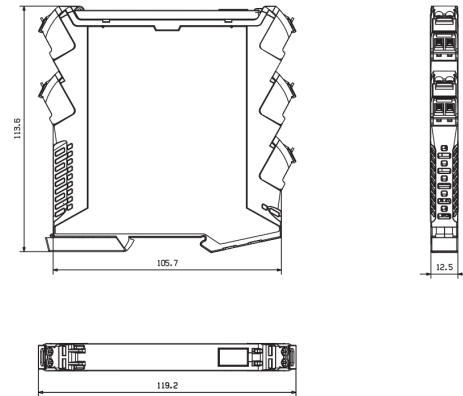

screenshot, configuration of voltage input as example

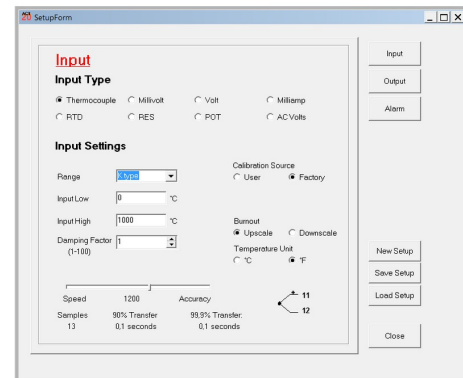

screenshot, configuration of temperature input as example

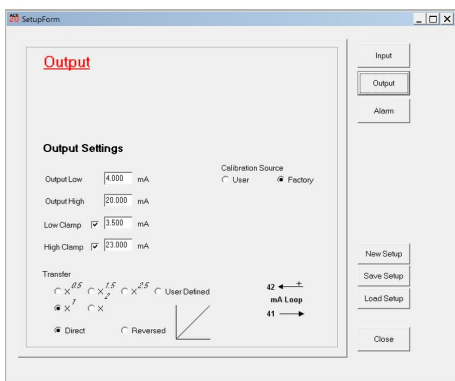

screenshot, configuration of analogue output as example

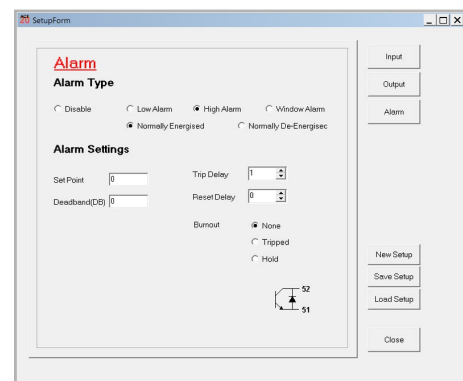

screenshot, configuration of alarm output (limit value) as example