

PRODUCT DATA SHEET / DATENBLATT

P/N 624 663 3 02

Crimping die set for use with the following hand tools or CM25 crimp machines
Crimpeinheit für folgende Handwerkzeuge oder CM25 Crimpmaschinen



P/N 624 000 6
P/N 624 000 3



P/N 6370 0100 1 (EU)
P/N 6370 0200 1 (GB)
P/N 6370 0300 1 (USA)



P/N 636 025-1
P/N 636 025-5
P/N 636 025-6

Description
Bezeichnung

Crimping die set 12.663 incl. wire stop
Crimpeinsatz 12.633 incl. Drahtanschlag

Image
Darstellung

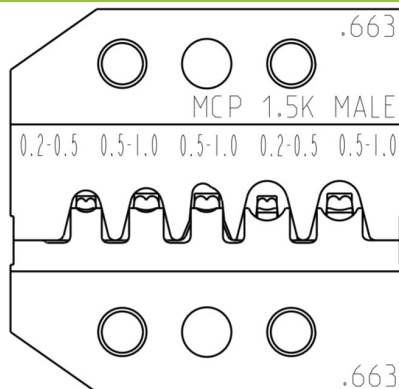

Capacity mm² or AWG
Kapazität mm² oder AWG

0,2 – 1,0 mm²
24 – 17 AWG

Application (contact P/N) Anwendung (Kontaktnummer)	Description	Contact Manufacturer	P/N- Strip	P/N- Loose	Type	Range mm²
	Micro Timer (EDS)	Tyco Electronics	1241730	1241731	Female	0,20 - 0,50
	Micro Timer (EDS)	Tyco Electronics	1241732	1241733	Female	0,50 - 1,00
	Micro Timer	Tyco Electronics	962942	962944	Female	0,20 - 0,50
	Micro Timer	Tyco Electronics	962943	962945	Female	0,50 - 1,00
	TAB 1.6 mm (EDS)	Tyco Electronics	964028	964029	Male	0,20 - 0,50
	Micro Timer	Tyco Electronics	964261	964262	Female	0,20 - 0,50
	Micro Timer	Tyco Electronics	964263	964264	Female	0,50 - 1,00
	TAB 1.6 mm	Tyco Electronics	964265	964266	Male	0,20 - 0,50
	TAB 1.6 mm	Tyco Electronics	964267	964268	Male	0,50 - 1,00
	TAB 1.6 mm (EDS)	Tyco Electronics	964269	964270	Male	0,50 - 1,00
	Micro Timer (EDS)	Tyco Electronics	964274	964275	Female	0,50 - 1,00
	Micro Timer	Tyco Electronics	964348	964349	Female	0,50 - 1,00
	Micro Timer	Tyco Electronics	965914	965915	Female	0,20 - 0,50
	Micro Timer (EDS)	Tyco Electronics	969005	969019	Female	0,20 - 0,50