	TYPE	PRODUCT SPECIFICATION		NUMBER	BUS-12-021	
	TITLE			PAGE	REVISION	
Gold Plated Clincher™ Connector			1 of 15		M	
			AUTHORIZED BY		DATE	
			C. Martinez		AUG 25 06	
			CLASSIFICATION			
			UNRESTRICTED			

1.0 GENERAL

Scope

This specification covers the Gold Plated Clincher™ Connector designed to terminate flat conductor, flat flexible cable and to interconnect this cable with 0.025 inch square or round pins on 0.100 inch centers. The specification is composed of the following sections.

<u>Paragraph</u>	<u>Title</u>	<u>Page</u>
1.0	GENERAL	1
2.0	APPLICABLE DOCUMENTS	1
3.0	REQUIREMENTS	2
3.1	Qualification	2
3.2	Material	2
3.3	Finish	2
3.4	Design and Construction	3
3.5	Electrical Characteristics	3
3.6	Mechanical Characteristics	4
3.7	Environmental Conditions	6
4.0	QUALITY ASSURANCE PROVISIONS	10
4.1	Equipment Calibration	10
4.2	Inspection Conditions	10
4.3	Qualification Inspection	11
4.4	Quality Conformance Inspection	12
4.5	Acceptance Inspection	13
5.0	NOTES AND DEFINITIONS	14

2.0 APPLICABLE DOCUMENTS

The following documents, of the issue in effect on the date of the latest revision of this specification, shall form a part of this specification to the extent specified herein.

Military Specifications

MIL-G-45204	Gold Plating, Electrodeposited
MIL-G-45662	Calibration System Requirement

Military Standards

MIL-STD-105	Sampling Procedures and Tables for Inspection by Attributes
MIL-STD-202	Test Methods for Electrical and Electronic Component Parts
EIA-364	Test Methods for Electrical Connectors

Federal Specifications

QQ-N-290	Nickel Plating (Electrodeposited)
QQ-C-533	Beryllium Alloy Copper Strip

	TYPE	PRODUCT SPECIFICATION		NUMBER	BUS-12-021		
	TITLE Gold Plated Clincher™ Connector			PAGE	2 of 15	REVISION	M
				AUTHORIZED BY	C. Martinez		DATE
				CLASSIFICATION	UNRESTRICTED		

Industry Specification/Standards

UL-94	Tests for Flammability of Plastic Materials
IPC-FC-220	Specification for Flat Cable, Flat-Conductor, Flexible, Unshielded
ASTM B122	Copper-Nickel-Tin Alloy, Copper-Nickel-Zinc Alloy (Nickel, Silver), and Copper-Nickel Alloy Plate, Sheet, Strip and Rolled Bar

3.0 **REQUIREMENTS**

3.1 Qualification

Connectors furnished under this specification shall be products capable of meeting the qualification test requirements specified herein.

3.2 Material

The material for each part shall be as specified herein, or equivalent. Substitute material shall meet the performance requirements of this specification.

3.2.1 Metallic Parts

3.2.1.1 **Contact Body.** The body shall be half-hard (HO2 Temper) Copper-Nickel-Tin Alloy 725 in accordance with ASTM B122.

3.2.1.2 **Contact Spring.** The spring shall be half-hard beryllium copper in accordance with QQ-C-533, heat treated to full-hard condition.

3.2.2 Housing. The housing shall be molded of flame retardant Polypropylene. The material shall be rated V-O in accordance with UL-94.

3.3 Finish

3.3.1 Contact Body. The body shall be plated in the contact area and lower crimp area with 30 microinches (minimum) gold per MIL-G-45204, Type II, Grade C, Class 0.

3.3.2 Contact Spring. The spring shall be plated on its convex side with 5 microinches (minimum) gold over .000050 Nickel under plating per MIL-G-45204, Type II, Grade C, Class 00.

	TYPE	NUMBER	
	PRODUCT SPECIFICATION	BUS-12-021	
TITLE Gold Plated Clincher™ Connector	PAGE	3 of 15	REVISION M
	AUTHORIZED BY C. Martinez	DATE AUG 25 06	
	CLASSIFICATION UNRESTRICTED		

3.4 Design and Construction

The connector shall be a multi-piece assembly having a single row of non-removable contacts with an insulation displacement style crimp termination. The female contact shall be a high reliability disconnect for 0.025 square or round male pins on 0.100 centers.

- 3.4.1 Installation. The connector shall simultaneously terminate up to 32 signal leads on 0.100 inch centers.
- 3.4.2 Mating. The connector shall be capable of mating and unmating by hand without the use of special tools within the specified temperature range.
- 3.4.3 Workmanship. Connectors shall be uniform in quality, and shall be free from burrs, scratches, cracks, voids, chips, blisters, pin holes, sharp edges, and other defects that will adversely affect life or serviceability.
- 3.4.4 Interchangeability. The connector shall be capable of mating with an appropriately constituted male connector or pin filed (see figure 2) of the same population without degradation in performance.

3.5 Electrical Characteristics

- 3.5.1 Current Rating. The maximum current rating of the connector shall be 2.0 ampere DC.
- 3.5.2 Contact Resistance. The contact resistance shall not exceed 15 milliohms (20 milliohms after environmental exposure) when measured in accordance with MIL-STD-202, Method 307; the following details shall apply:
 - a. Method of Connection - Attach current and voltage leads as shown in Figure 1.
 - b. Test Current - 1.0 ampere DC
- 3.5.3 Low Level Circuit Resistance. The low level circuit resistance shall not exceed 10 milliohms (20 milliohms after environmental exposure) when measured in accordance with EIA-364 TP45; the following details shall apply:
 - a. Method of Connection - See Figure 1
 - b. Test Current - 10 milliamperes DC, approximate
 - c. Open-Circuit Voltage - 50 millivolts, maximum

	TYPE	PRODUCT SPECIFICATION		NUMBER	BUS-12-021		
	TITLE	Gold Plated Clincher™ Connector		PAGE	4 of 15	REVISION	M
				AUTHORIZED BY	C. Martinez	DATE	AUG 25 06
				CLASSIFICATION	UNRESTRICTED		

3.5.4 Insulation Resistance. The insulation resistance of the unterminated connector shall be not less than 5000 megohms (10 megohms within 15 minutes after exposure to the humidity environment described in 3.7.2) when measured in accordance with MIL-STD-202, Method 302; the following details shall apply:

- a. Test Condition - B (500 volts DC)
- b. Points of Measurement - Between adjacent contacts

3.5.5 Dielectric Withstanding Voltage. There shall be no evidence of arc-over, insulation breakdown, or excessive leakage current (> 1.0 milliampere) when the unterminated connector is tested in accordance with MIL-STD-202, Method 301; the following details shall apply:

- a. Test Potential - 1000 volts RMS, 60 Hz (sea-level pressure)
- b. Test Duration - 60 seconds
- c. Points of Measurement - Between adjacent contacts

3.6 Mechanical Characteristics

3.6.1 Total Mating and Unmating Force. The total force to mate (or unmate) the terminated connector with an appropriately populated header consisting of properly configured (see Figure 2) 0.025 inch square or round pins shall not exceed 300 grams times the number of terminals. The test shall be in accordance with EIA-364 TP13, at a cross-head speed of one (1) inch per minute.

For product with an external mechanical locking device, the total mating force shall not exceed 300gm times the number of terminals plus 521gm for the mechanical latch.

For product with an external mechanical locking device, the total unmating force shall not be more than 300gm times the number of terminals plus 1200gm for the mechanical latch.

3.6.2 Individual Contact Withdrawal Force. When measured using a minimum gage configured as shown in Figure 3, the individual contact withdrawal force shall be not less than 25 grams. The test shall be in accordance with EIA-364 TP37; the following details shall apply:

- a. Test Procedure - 1
- b. Speed of Withdrawal - 1 inch per minute
- c. Insertion Depth - 0.230 to 0.250 inch
- d. Number of Prior Activations - 1 (with maximum gage shown in Figure 3)

3.6.3 Cable Retention. The contact termination shall withstand, without loss of continuity, an evenly distributed force of 10 pounds per inch-of-cable-width applied to the cable in a direction parallel to the contact axis.



	TYPE	NUMBER	
	PRODUCT SPECIFICATION	BUS-12-021	
TITLE	Gold Plated Clincher™ Connector	PAGE	REVISION
		5 of 15	M
		AUTHORIZED BY	DATE
		C. Martinez	AUG 25 06
		CLASSIFICATION	
		UNRESTRICTED	

FIGURE 2 - MATING HEADER

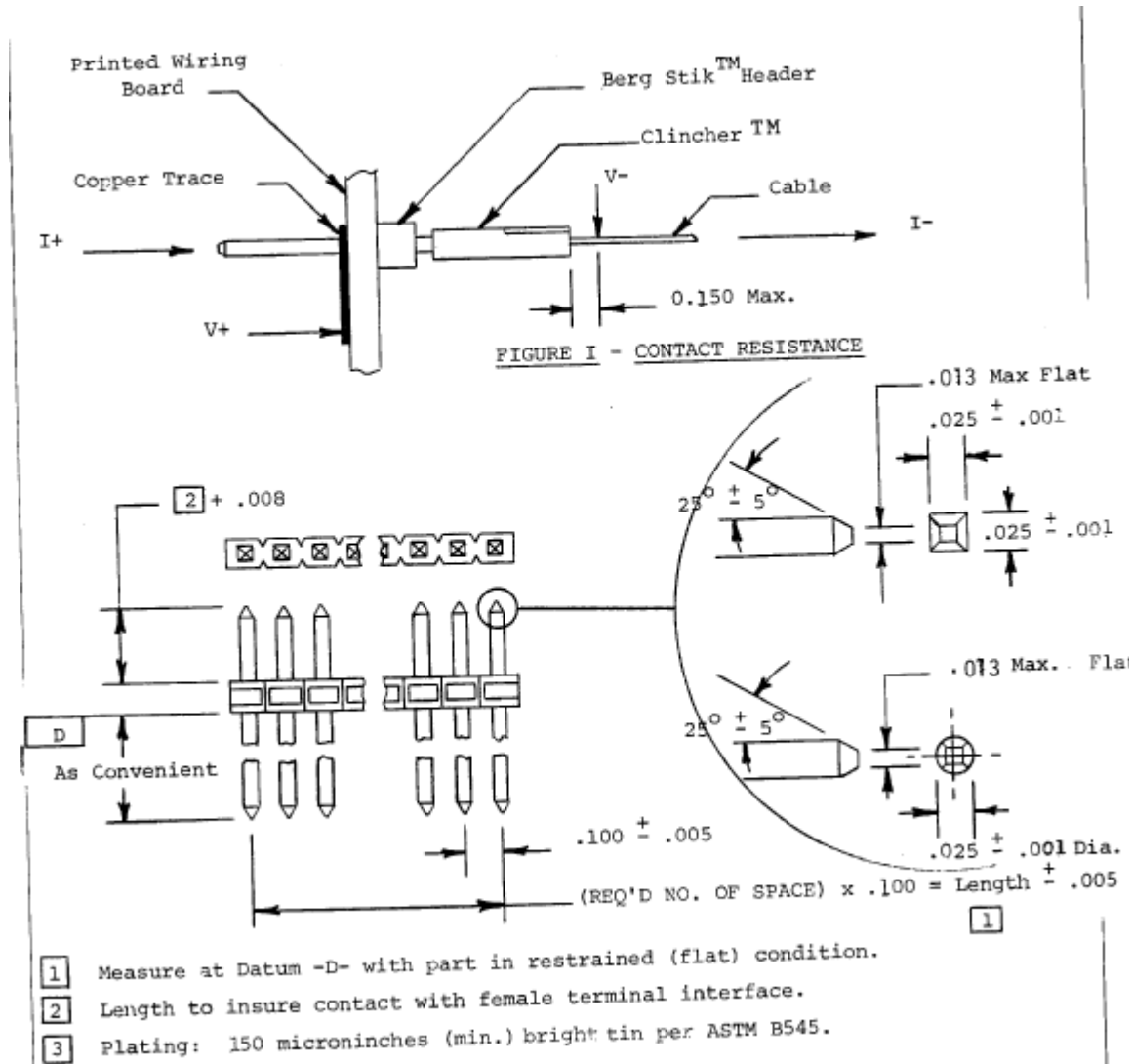

	TYPE	NUMBER	
	PRODUCT SPECIFICATION	BUS-12-021	
TITLE Gold Plated Clincher™ Connector	PAGE	6 of 15	REVISION M
	AUTHORIZED BY C. Martinez	DATE AUG 25 06	
	CLASSIFICATION UNRESTRICTED		

3.6.4 Cable Flex Resistance (see 5.1). The contact termination shall withstand, without loss of continuity, 100 cycles of flexing; the following details shall apply:

- a. Tension on Cable - 2 pounds per inch-of-cable-width
- b. Flex Angle - 140° as shown in Figure 4

3.6.5 Durability. After 100 mating cycles of the connector and an appropriately populated header consisting of properly configured (see Figure 2) 0.025 inch square or round pins, the total mating and unmating force shall not exceed 300 grams times the number of terminals (see 3.6.1), the individual contact withdrawal force shall be not less than 25 grams (see 3.6.2) and the contact resistance shall not exceed 20 milliohms (see 3.5.2).

3.6.6 Mechanical Latch Retention. Total Force required to dislodge the latch only of an unloaded housing with the appropriate mating header shall be 4lbs. Minimum.

3.6.7 Mechanical Latch Normal Force. Force required to depress the mechanical latch .040 of an inch. Is 3 lb. Maximum at ambient temperature. (See Figure 6)

3.6.8 Latch Durability. Latch to be depressed .040 of inch and return to it's original position +/- .010 after initial and 25 cycles at ambient temperature and at -65 C degrees. There shall be no evidence of cracking of the latch after cycling.

3.7 Environmental Conditions

3.7.1 Thermal Shock (see 5.2). After exposure of the mated connector and header to alternate periods of extreme high and low temperature, there shall be no evidence of cracking or crazing of the insulator or other physical damage to the connector; the dielectric withstanding voltage of an unterminated connector shall be not less than 1000 volts rms, 60 Hz (see 3.5.5). The test shall be in accordance with MIL-STD-202, Method 107; the following details shall apply:

- a. Test Condition - B (5, 1-hour cycles)
- b. Temperature Range - -65°C to +105°C
- c. Time at each Temperature - 30 minutes, minimum
- d. Transfer Time - 30 seconds, maximum

3.7.2 Humidity. Within one (1) hour after exposure to a high humidity environment, the insulation resistance of an unterminated connector shall be not less than 5,000 megohms (see 3.5.4); the low level circuit (contact) resistance of the mated connector and header shall not exceed 20 milliohms (see 3.5.3). The test shall be in accordance with MIL-STD-202, Method 103; the following details shall apply:

- a. Test Condition - B (96 hours)
- b. Chamber Temperature - +40°C
- c. Relative Humidity - 90%

	TYPE	PRODUCT SPECIFICATION		NUMBER	BUS-12-021		
	TITLE	Gold Plated Clincher™ Connector		PAGE	7 of 15	REVISION	M
				AUTHORIZED BY	C. Martinez	DATE	AUG 25 06
				CLASSIFICATION	UNRESTRICTED		

- 3.7.3 High Temperature Life (see 5.2). After exposure of the unterminated connector to a high temperature operating environment, the insulation resistance shall be not less than 5,000 megohms (see 3.5.4); the contact resistance of the mated connector and header shall not exceed 20 milliohms (see 3.5.2). The test shall be in accordance with MIL-STD-202, Method 108; the following details shall apply:
- Chamber Temperature - +85°C, (+105°C, unterminated connector only)
 - Test Condition - B (250 hours)
 - Operating Conditions - 0.5 ampere DC current through all signal contacts of terminated connector; duty cycle: 45 minutes ON and 15 minutes OFF
- 3.7.4 Shock (see 5.3). There shall be no evidence of physical or mechanical damage or disassociation of parts when the mated connector and header are subjected to transient accelerations. During and after each shock, the contacts shall exhibit no discontinuity greater than 1 microsecond. The test shall be in accordance with MIL-STD-202, Method 213; the following details shall apply:
- Test Condition - 1 (100g, 6 millisecond sawtooth)
 - Number of Shocks - 3 shocks in both directions along each of three (3) orthogonal axes (18 total)
 - Mounting - see Figure 5
- 3.7.5 Vibration (see 5.3). There shall be no evidence of physical or mechanical damage or disassociation of the part when the mated connector and header are subjected to prolonged mechanical vibration; during vibration along each axis, the contacts shall exhibit no discontinuity greater than 1 microsecond. At the completion of the test, the individual contact withdrawal force shall be no less than 25 grams (see 3.6.2) and the contact resistance shall not exceed 20 milliohms (see 3.5.2). The test shall be in accordance with MIL-STD-202, Method 204; the following details shall apply:
- Test Condition - B (+15g, 10 to 2000 Hz)
 - Test Duration - 4 hours along each of three (3) orthogonal axes (12 hours total)
 - Mounting - see Figure 5

	TYPE	NUMBER	
	PRODUCT SPECIFICATION	BUS-12-021	
TITLE	Gold Plated Clincher™ Connector	PAGE	REVISION
		8 of 15	M
		AUTHORIZED BY	DATE
		C. Martinez	AUG 25 06
		CLASSIFICATION	
		UNRESTRICTED	

FIGURE 4 - FLEX RESISTANCE



	TYPE PRODUCT SPECIFICATION	NUMBER BUS-12-021	
TITLE Gold Plated Clincher™ Connector		PAGE 9 of 15	REVISION M
		AUTHORIZED BY C. Martinez	DATE AUG 25 06
CLASSIFICATION UNRESTRICTED			

FIGURE 5 - MOUNTING FOR SHOCK AND VIBRATION

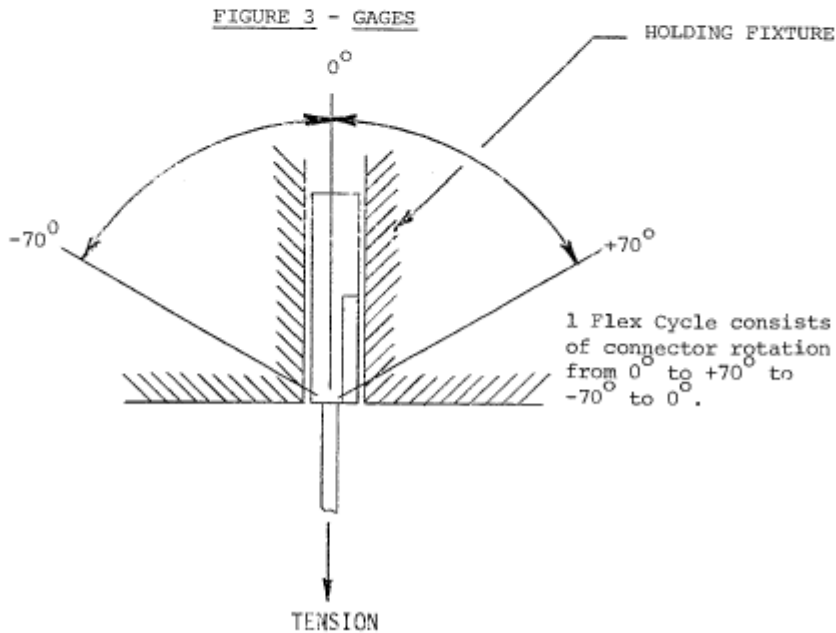
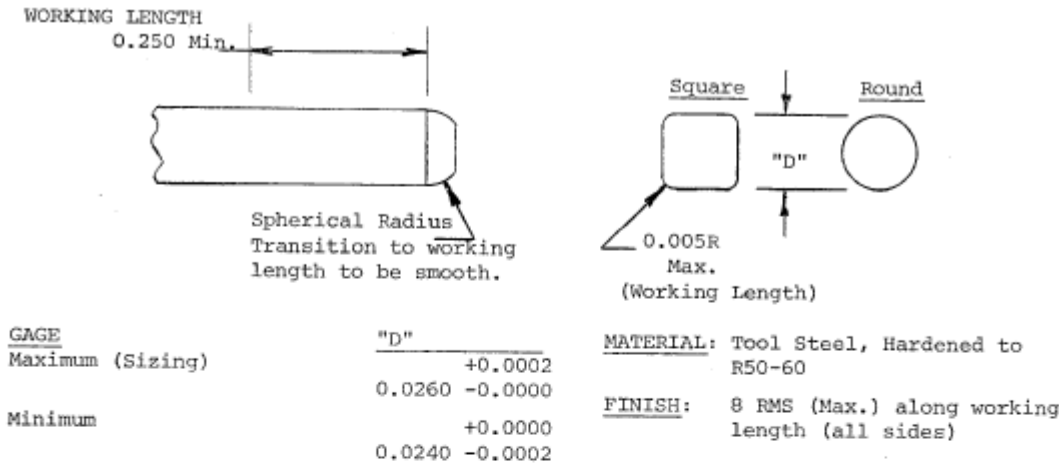
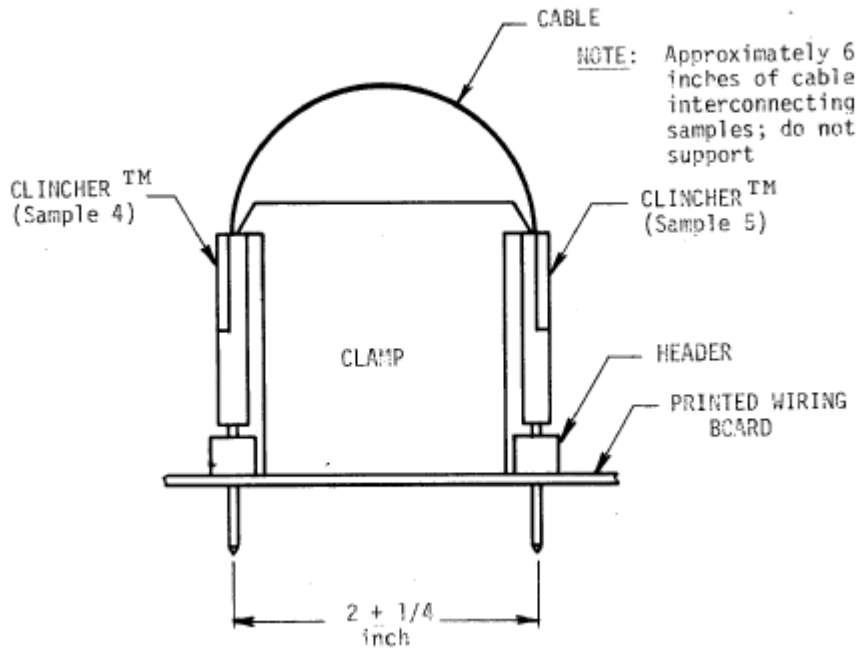
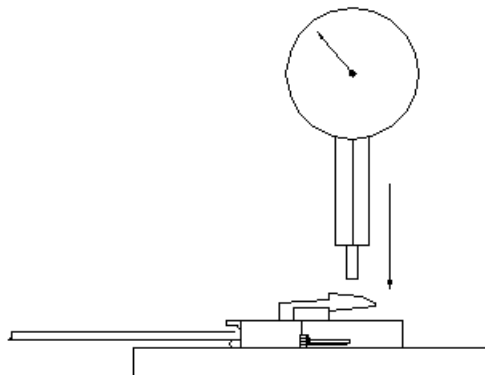



Figure 6 External Latch Testing



	TYPE	PRODUCT SPECIFICATION		NUMBER	BUS-12-021	
	TITLE			PAGE	REVISION	
Gold Plated Clincher™ Connector			10 of 15		M	
			AUTHORIZED BY		DATE	
			C. Martinez		AUG 25 06	
			CLASSIFICATION			
			UNRESTRICTED			

3.7.6 Hydrogen Sulfide (H₂S) Atmosphere. After exposure of the mated connector and header to a moist H₂S atmosphere (approximately 3 ppm), the low level circuit (contact) resistance shall not exceed 20 milliohms (see 3.5.3). The following details shall apply:

- a. Test Medium - solution of 120 grams Na₂S·9₂O in 500 milliliters of distilled water, with 14 grams K₂HPO₄ added immediately prior to test.
- b. Test Temperature - +40°C
- c. Test Duration - 48 hours in a sealed 9,000 cubic centimeter glass container

3.7.7 Salt Spray. After exposure of the mated connector and header to a salt fog atmosphere, the low level circuit (contact) resistance shall not exceed 20 milliohms (see 3.5.3). The test shall be in accordance with MIL-STD-202, Method 101; the following details shall apply:

- a. Test Condition - B (48 hours)
- b. Solution Concentration - 5 percent (by weight)

4.0 QUALITY ASSURANCE PROVISIONS

4.1 Equipment Calibration

All test equipment and inspection facilities used in the performance of any test shall be maintained in a calibration system in accordance with MIL-C-45662.

4.2 Inspection Conditions

Unless otherwise specified herein, all inspections shall be performed under the following ambient conditions.

- a. Temperature - 25°C +_ 5°C
- b. Relative Humidity - 30 to 80%
- c. Barometric Pressure - local ambient

4.3 Qualification Inspection

Qualification inspection shall be performed on sample units produced with equipment and procedures normally used in production.

4.3.1 Sample. Nine (9) connectors shall be subjected to the Qualification Inspection.

	TYPE	PRODUCT SPECIFICATION		NUMBER	BUS-12-021			
	TITLE Gold Plated Clincher™ Connector			PAGE	11 of 15		REVISION	M
				AUTHORIZED BY	C. Martinez		DATE	AUG 25 06
				CLASSIFICATION	UNRESTRICTED			

4.3.2 **Preparation of Samples.** The various test samples shall be configured and terminated as shown in Table III. The cable shall conform to the requirements of IPC Specification FC-220, Type A and B, Tolerance Class IV, except that the margin shall be 0.069 inch (nominal) and the conductor width shall be 0.062 +_ 0.003 inch.

TABLE III - QUALIFICATION INSPECTION SAMPLES

Sample No.	No. of Positions	Crimp Height	Mating Header	
			Square	Round
1, 2 & 4-6, 10	19	Maximum	X	-
3	19	-	-	-
7-9	5	Minimum	-	X

4.3.3 **Test Sequence.** The sample connectors shall be subjected to the inspections specified in Table IV, in the order shown.

TABLE IV - QUALIFICATION INSPECTION

Examination or Test	Para	1	2	3	4	5	6	7	8	910*
Total Mating and Unmating Force	3.6.1	-	-	-	X	X	X	X	X	XX
Individual Contact Insertion and Withdrawal Force	3.6.2	-	-	-	X	-	X	X	X	X-
Cable Retention	3.6.3	-	X	-	-	X	X	X	-	--
Cable Flex Resistance	3.6.4	X	-	-	X	-	-	-	X	--
Contact Resistance	3.5.2	X	X	-	X	X	X	X	X	X-
Insulation Resistance	3.5.4	-	-	X	-	-	-	-	-	--
Dielectric Withstanding Voltage	3.5.5	-	-	X	-	-	-	-	-	--
Thermal Shock	3.7.1	X	X	X	-	-	-	-	-	--
Humidity	3.7.2	X	X	X	-	-	-	-	-	--
High Temperature Life	3.7.3	X	X	X	-	-	-	-	-	--
Shock	3.7.4	-	-	-	X	X	-	-	-	--
Vibration	3.7.5	-	-	-	X	X	-	-	-	--
Durability	3.6.5	-	-	-	X	-	X	X	X	X-
Hydrogen Sulfide Atmosphere	3.7.6	-	-	-	X	X	X	X	X	X-
Salt Spray	3.7.7	-	-	-	X	X	X	X	X	X-
Mechanical Latch Retention	3.6.6	-	-	-	-	-	-	-	-	X
Mechanical Latch Normal Force	3.6.7	-	-	-	-	-	-	-	-	X
Mechanical Latch Durability	3.6.8	-	-	-	-	-	-	-	-	X

*Latching Clincher™ test sequence 10 on separate sample groups for each test.

	TYPE	PRODUCT SPECIFICATION		NUMBER	BUS-12-021			
	TITLE Gold Plated Clincher™ Connector			PAGE	12 of 15		REVISION	M
				AUTHORIZED BY	C. Martinez		DATE	AUG 25 06
				CLASSIFICATION	UNRESTRICTED			

4.4 Quality Conformance Inspection

Quality conformance inspection shall be performed on sample units produced with equipment and procedures normally used in production.

- 4.4.1 Sample. Six (6) of the largest population connectors, available at the time of test, shall be selected at random from items produced and subjected to the Quality Conformance Inspection.
- 4.4.2 Preparation of Samples. The various test samples shall be configured and terminated as shown in Table V.
- 4.4.3 Test Sequence. The sample connectors shall be subjected to the inspections specified in Table VI, in the order shown.
- 4.4.4 Failure. If the connector fails to pass the Quality Conformance Inspection, appropriate corrective action shall be taken on the materials or processes and additional sample units shall be subjected to the Quality Conformance Inspection to verify the effectiveness of the action.

TABLE V - QUALITY CONFORMANCE INSPECTION SAMPLES

<u>Sample No.</u>	<u>Crimp Height</u>	<u>Mating Header</u>	
		<u>Square Pin</u>	<u>Round Pin</u>
1, 2, 4 & 5, 7	Maximum	X	X
3	-	-	-
6	Minimum	-	X

	TYPE	NUMBER	
	PRODUCT SPECIFICATION	BUS-12-021	
TITLE	Gold Plated Clincher™ Connector	PAGE	REVISION
		13 of 15	M
		AUTHORIZED BY	DATE
		C. Martinez	AUG 25 06
		CLASSIFICATION	
		UNRESTRICTED	

TABLE VI - QUALITY CONFORMANCE INSPECTION

Examination or Test	Para	1	2	3	4	5	6	7*
Total Mating and Unmating Force	3.6.1	-	-	-	X	X	X	X
Individual Contact Insertion and Withdrawal Force	3.6.2	-	-	-	X	X	-	-
Cable Retention	3.6.3	X	-	-	X	-	-	-
Cable Flex Resistance	3.6.4	-	X	-	-	X	-	-
Contact Resistance	3.5.2	X	X	-	X	X	X	-
Insulation Resistance	3.5.4	-	-	X	-	-	-	-
Dielectric Withstanding Voltage	3.5.5	-	-	X	-	-	-	-
Thermal Shock	3.7.1	X	-	X	-	-	-	-
Humidity	3.7.2	X	X	X	-	-	-	-
Durability	3.6.5	X	X	X	X	-	X	-
Hydrogen Sulfide Atmosphere	3.7.6	-	-	-	X	X	X	-
Salt Spray	3.7.7	-	-	-	X	X	X	-
Mechanical Latch Retention	3.6.6							X
Mechanical Latch Normal Force	3.6.7							X
Mechanical Latch Durability	3.6.8							X

*Latching Clincher™ test sequence 7 on separate sample groups for each test

4.5 Acceptance Inspection

Acceptance Inspection shall consist of the examinations and inspections specified in Table VII.

TABLE VII - ACCEPTANCE INSPECTION

Examination	AQL	
	Major	Minor
Visual and Mechanical	1%	4%

- 4.5.1 **Inspection Lot.** An inspection lot shall consist of all connectors produced under essentially the same conditions and offered for inspection at one time.
- 4.5.2 **Sampling Plan.** A) Statistical sampling and inspection shall be performed for General Inspection, B) FCI is committed to a Zero Defect Philosophy utilizing Statistical Process Control. Our commitment to Zero Defects is a continuous improvement in process and product quality.
- 4.5.3 **Rejected Lots.** Rejected lots shall be reworked to correct the defects or screened to remove defective units and re-submitted for inspection.
- 4.5.4 **Disposition of Sample Units.** Sample units that have been subjected to the acceptance inspection shall be considered deliverable on the contract or purchase order.

	TYPE PRODUCT SPECIFICATION	NUMBER BUS-12-021	
TITLE Gold Plated Clincher™ Connector	PAGE 14 of 15	REVISION M	
	AUTHORIZED BY C. Martinez	DATE AUG 25 06	
CLASSIFICATION UNRESTRICTED			

5.0 NOTES AND DEFINITIONS

5.1 Cable Flex Resistance

The connector design does not provide the strain relief usually considered necessary for the type of extreme handling represented by this test. While the connector-cable interface will withstand repeated flexing under the specific conditions of test described in this specification, long-term use in a similar environment should include specific provisions for anchoring the cable close to the connector.

5.2 High-Temperature Limit

The Underwriters Laboratories "Temperature Index" for the material used in the housing is +65°C, for purposes of long term exposure. The rating must be kept in mind in any projected connector use.

5.3 Shock and Vibration Environments

The overall connector design (low contact population, single row layout, low force contacts, etc.) precludes self-retention during these mechanical environments. Some latching or other retention technique must be provided by the user if the connector will be exposed to these conditions.

	TYPE	PRODUCT SPECIFICATION		NUMBER	BUS-12-021	
	TITLE			PAGE	REVISION	
Gold Plated Clincher™ Connector			15 of 15		M	
			AUTHORIZED BY		DATE	
			C. Martinez		AUG 25 06	
			CLASSIFICATION			
			UNRESTRICTED			

REVISION RECORD

<u>REV</u>	<u>PAGE</u>		<u>EC #</u>	<u>DATE</u>
E	All		12349	12/07/84
F	3, 14		13190	12/18/85
G	3, 6		13650	11/25/86
H	All		V11789	06/19/91
J	13		V12247	08/07/91
K	All	Revised format to be consistent with GS-01-001, and change BERG, Dupont, etc. references to FCI.	V01904	07/27/00
L	ALL	Add section 3.6.6, 3.6.7 and 3.6.8 mating/unmating information for External locking device to 3.6.1, Add fig. 6 Add sequence 10 to table IV & add sequence 7 to table VI.	V03-0776	07/15/03
M	ALL 1	Revised format; change logo. MIL-STD-1344 was replaced by EIA-364	M06-0326	08/25/06