

NUMBER <b>GS-20-130</b>	TYPE <b>APPLICATION SPECIFICATION</b>		
TITLE <b>Handling Procedures and Remarks for 1.0mm Pitch FPC/FFC Connector SFW__R-3/4ST__LF</b>		PAGE 1 of 7	REVISION A
		AUTHORIZED BY M.YAMASHITA	DATE 26 OCT 09
CLASSIFICATION <b>UNRESTRICTED</b>			

1. SUMMARY OF THE CONNECTOR

1-1 MOUNTING METHOD OF THE CONNECTOR ON P.C.BOARD

This connector applies the construction which copes with automatic mounting and SMT. Therefore please proceed reflow soldering after mounting it on P. C. Board by automatic mounting machine.

Package style of connector	Plastic tape which cope with JIS C 0806
Automatic mounting machine	One by one system
Soldering	Reflow soldering (Infrared reflow system etc.)

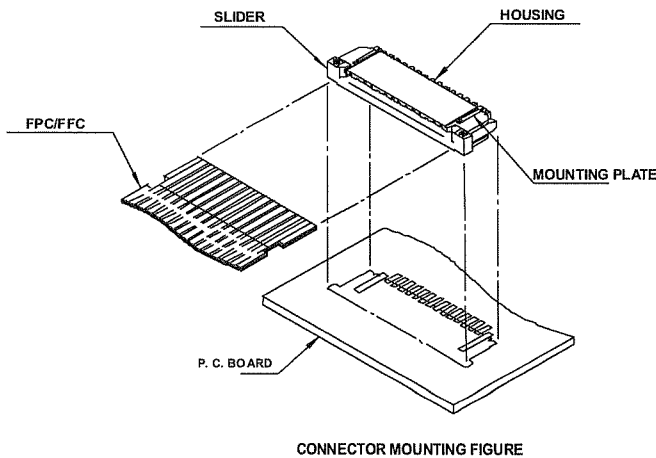
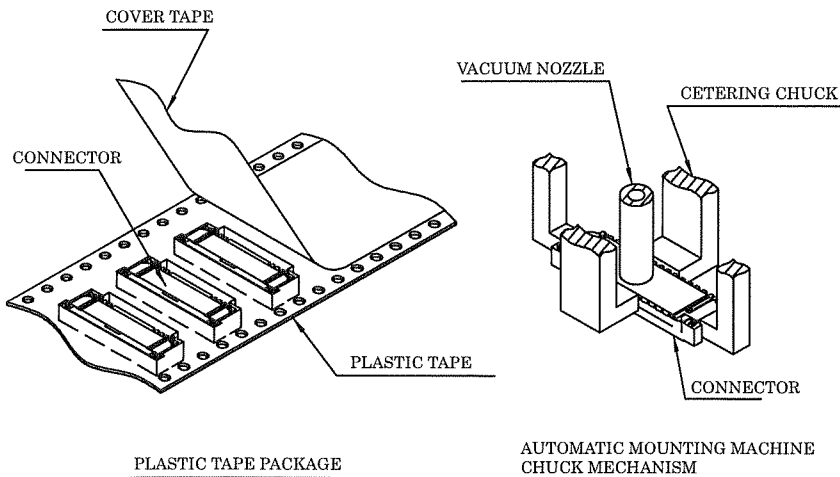

NOTE) Please refer to the drawings attached to the specification for details of dimensions etc.

NUMBER <b>GS-20-130</b>	TYPE <b>APPLICATION SPECIFICATION</b>	<b>FCI</b>	
TITLE <b>Handling Procedures and Remarks for 1.0mm Pitch FPC/FFC Connector SFW__R-3/4ST__LF</b>		PAGE 2 of 7	REVISION A
		AUTHORIZED BY M.YAMASHITA	DATE 26 OCT 09
		CLASSIFICATION <b>UNRESTRICTED</b>	

1-2. INTERNAL STRUCTURE

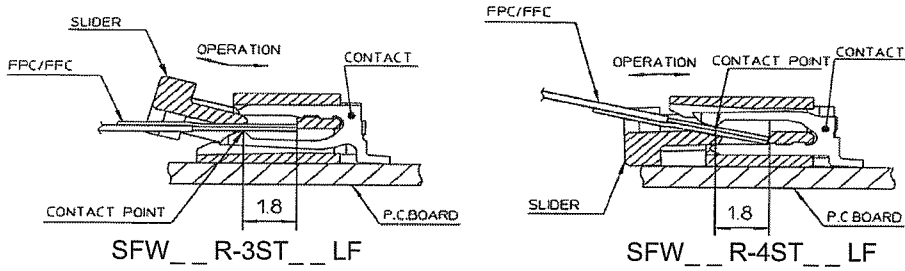

1-3 STRONG POINT

The merit of this connector is to apply cable-lock mechanism and the cable-lock mechanism provides the following advantages.

Slight slant of cable from vertical insertion line after insertion of cable temporarily, can be corrected by slider-lock operation. (Prevention of cable insufficient insertion)

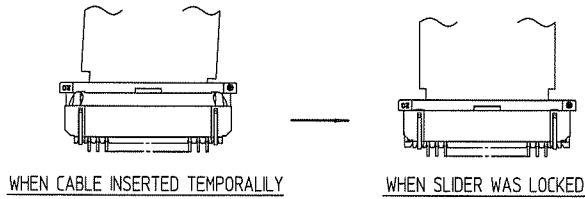

※ REMARKS

1). In case of existing large slant of cable, in some cases, the slant of cable can not be corrected.

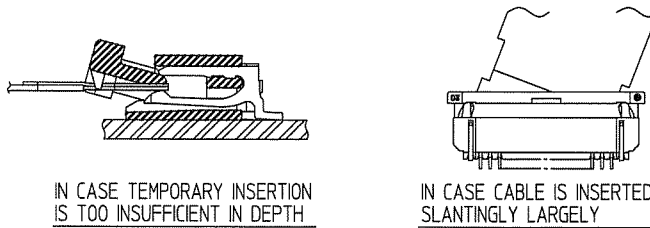

2). Please use cable with cut-out as shown in the following figure by all means.

(Please refer to the drawing attached to our specification for detail dimensions.)

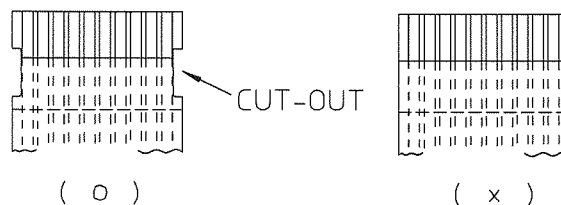

NUMBER <b>GS-20-130</b>	TYPE <b>APPLICATION SPECIFICATION</b>		
<b>TITLE</b> <b>Handling Procedures and Remarks for 1.0mm Pitch</b> <b>FPC/FFC Connector</b> <b>SFW__R-3/4ST__LF</b>		PAGE 3 of 7	REVISION A
		AUTHORIZED BY M.YAMASHITA	DATE 26 OCT 09
		CLASSIFICATION <b>UNRESTRICTED</b>	

2. BASIC OPERATION PROCEDURES OF CONNECTOR

Conductor connections after soldered the connector on P. C. Board shall be done by the following procedures.  
Pulling conductor forcibly in the condition of slider being locked must be avoided.

Works	No	Operating Procedure
Connecting of conductor	2-1	Provide open status by pulling slider
	2-2	Match connecting side of conductor to connecting side of connector
	2-3	Fix temporarily by inserting conductor into card slot
	2-4	Provide lock status by pressing slider into
Removing of conductor	2-5	Provide open status by pulling slider
	2-6	Extract conductor to upper slant direction against P.C. Board

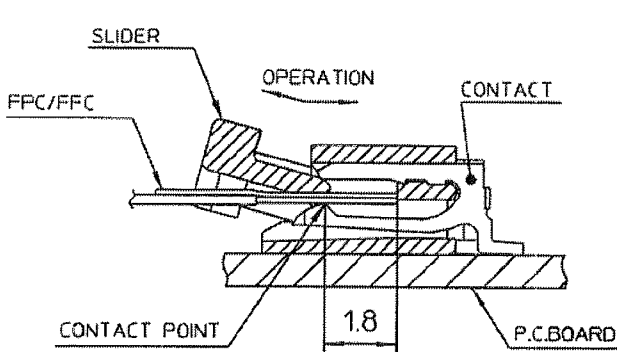

SFW\_\_R-3ST\_\_LF

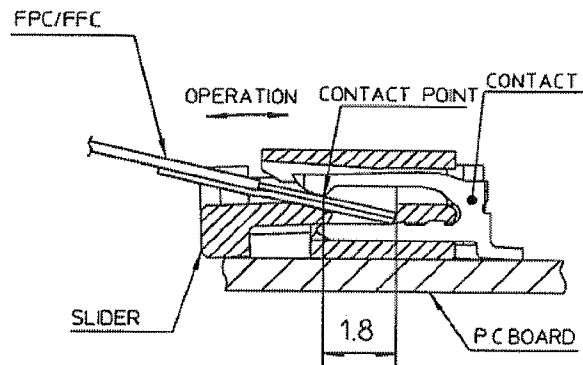

SFW\_\_R-4ST\_\_LF

NUMBER <b>GS-20-130</b>	TYPE <b>APPLICATION SPECIFICATION</b>		
TITLE <b>Handling Procedures and Remarks for 1.0mm Pitch FPC/FFC Connector SFW__R-3/4ST__LF</b>		PAGE 4 of 7	REVISION A
		AUTHORIZED BY M.YAMASHITA	DATE 26 OCT 09
		CLASSIFICATION <b>UNRESTRICTED</b>	

### 3. HANDLING PROCEDURE DETAILS AND REMARKS

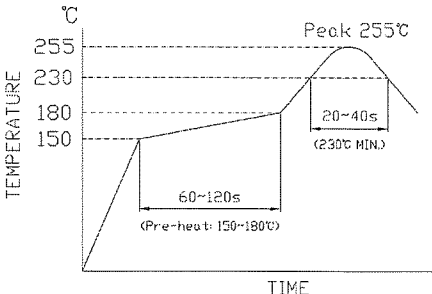
No	Procedure	Remarks
3-1	<p><b><u>Cream Solder Printing</u></b> Print cream solder with adequate quantity on P.C. B pattern. &lt;Recommended cream solder&gt;</p> <ul style="list-style-type: none"> <li>• JIS Z 3282 Sn96.5Ag3.0Cu0.5</li> <li>• Stencil thickness: 0.15 ~ 0.2mm.</li> </ul>	<ul style="list-style-type: none"> <li>• Please refer to the drawing attached to the specification for recommended P.C.B pattern dimensions.</li> <li>• Please print cream solder with adequate quantity by adjusting thickness of stencil.</li> </ul>
3-2	<p><b><u>Mounting on P.C. Board</u></b> By using automatic mounting machine (One by one system) which copes with plastic tape, mount the connector on predetermined position on P.C. Board coated with cream solder.</p>	<ul style="list-style-type: none"> <li>• Please confirm carefully mounting accuracy of automatic mounting machine and dimensional accuracy of P.C.B.</li> <li>• Use by selecting adequate one for vacuum nozzle diameter and centering chuck shape of automatic mounting machine.</li> </ul>
3-3	<p><b><u>Reflow soldering</u></b> 1) Soldering method Solder by using reflow bath. &lt;Recommended soldering condition&gt;</p>  <p style="text-align: center;"><u>Recommended reflow temperature profile</u></p> <p>Note) Temperature shown above indicates it of contact terminal portion.</p> <p>2) Cleaning Cleaning of flux residue is recommended by considering the reliability of insulation resistance and corrosion characteristics after soldered.</p>	<ul style="list-style-type: none"> <li>• Please check the reflow soldering condition for your own application beforehand due to different conditions with soldering devices, P.C. Boards, etc.</li> <li>• No moisture treatment before reflow process.</li> </ul>

NUMBER <b>GS-20-130</b>	TYPE <b>APPLICATION SPECIFICATION</b>		
TITLE <b>Handling Procedures and Remarks for 1.0mm Pitch FPC/FFC Connector SFW__R-3/4ST__LF</b>		PAGE 5 of 7	REVISION A
		AUTHORIZED BY M.YAMASHITA	DATE 26 OCT 09
CLASSIFICATION <b>UNRESTRICTED</b>			

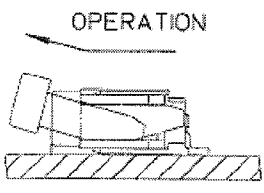
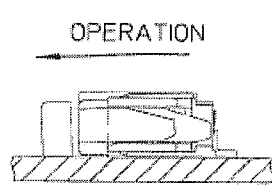
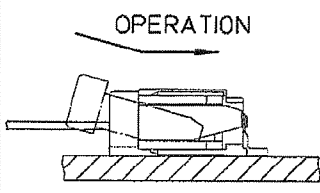
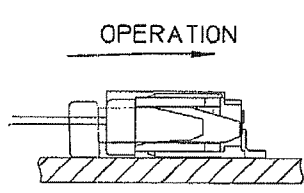
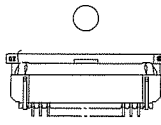
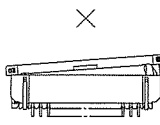
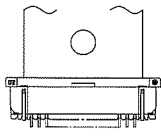
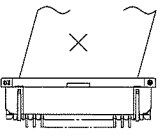
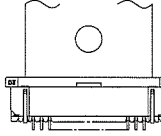
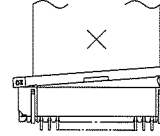
No	Procedure	Remarks
3-4	<p><b>Connection of conductor (FPC/FFC)</b></p> <p>1) Provide open status by operating slider. In this case, operate both edges of slider by all means. (Slider is fixed by keeping lift up condition on the slant.)</p> <div style="display: flex; justify-content: space-around;"> <div style="text-align: center;"> <p>OPERATION</p>  <p>SFW__R-3ST__LF</p> </div> <div style="text-align: center;"> <p>OPERATION</p>  <p>SFW__R-4ST__LF</p> </div> </div> <p>2) Conductive side(Finger portion) of conductor is matched to contacting portion of connector.</p> <p>3) Insert conductor from the inserting window of connector parallel until it fits against. (In this condition, conductor is fixed temporarily.)</p> <p>4) After confirming that the conductor is inserted correctly, lock slider. In this case, confirm that both edges are locked securely by operating both edges of slider.</p> <div style="display: flex; justify-content: space-around;"> <div style="text-align: center;"> <p>OPERATION</p>  <p>SFW__R-3ST__LF</p> </div> <div style="text-align: center;"> <p>OPERATION</p>  <p>SFW__R-4ST__LF</p> </div> </div>	<ul style="list-style-type: none"> <li>When providing open status by operating slider, operate the both edges parallel until they stop perfectly.</li> </ul> <div style="display: flex; justify-content: space-around;">   </div> <ul style="list-style-type: none"> <li>Make conductor vertically against slider by all means at the condition of being slider locked by inserting conductor.</li> </ul> <div style="display: flex; justify-content: space-around;">   </div> <ul style="list-style-type: none"> <li>At the condition of being slider locked, adjust so as not to have any gap at connecting portion of slider and main body.</li> </ul> <div style="display: flex; justify-content: space-around;">   </div> <ul style="list-style-type: none"> <li>Do not put excess force on conductor and connector at the condition of being conductor mated.</li> </ul>

NUMBER <b>GS-20-130</b>	TYPE <b>APPLICATION SPECIFICATION</b>		
TITLE <b>Handling Procedures and Remarks for 1.0mm Pitch FPC/FFC Connector SFW__R-3/4ST__LF</b>		PAGE 6 of 7	REVISION A
		AUTHORIZED BY M.YAMASHITA	DATE 26 OCT 09
		CLASSIFICATION <b>UNRESTRICTED</b>	

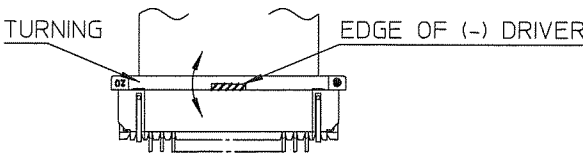
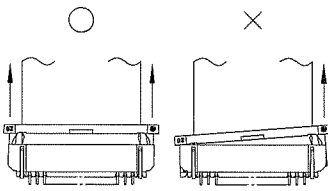
No	Procedure	Remarks
3-5	<p><b>Removing of conductor (FPC/FFC)</b></p> <p>1) Provide open status by operating slider. In this case, operate both edges of slider by all means. Also, for SFW__R-3ST__LF (Lower contacts type), operate by turning minus driver after putting into the slot for operating fixture.</p>  <p>2) Extract conductor to upper slant direction against P.C.Board.</p>	<ul style="list-style-type: none"> <li>Excessive operation may cause breakage of slider.</li> </ul>  <ul style="list-style-type: none"> <li>Remove conductor after making slider open status perfectly.</li> </ul>

4. OTHER REMARKS

- Do not insert lead other than FFC, FPC, and probe etc. directly into contacting portion.  
Since CIC (Conductor such as silver paste, carbon etc.) can not be used for this product, please consult us separately.
- Do not make any soldering in the condition of being conductor mated.
- Operating force of slider may become larger considerably if number of conductors increase.

5. STORAGE OF CONNECTOR

- Avoid the places where dust, oil and water etc. are splashed or have direct sunshine.  
Solderability may be deteriorated if the connector is stocked for long time under high temperature, high humidity.
- Preferable stock condition  
Temperature : Less than 30°C  
Humidity : Less than 60% (Relative Humidity)  
Period : Within 3 months

NUMBER <b>GS-20-130</b>	TYPE <b>APPLICATION SPECIFICATION</b>		
TITLE <b>Handling Procedures and Remarks for 1.0mm Pitch FPC/FFC Connector SFW__R-3/4ST__LF</b>		PAGE 7 of 7	REVISION A
		AUTHORIZED BY M.YAMASHITA	DATE 26 OCT 09
		CLASSIFICATION <b>UNRESTRICTED</b>	

REVISION RECORD

REV.	PAGE	DESCRIPTION	ECR #	DATE
A	All	New release	J09-0378	26 OCT 09