

NUMBER GS-20-401	TYPE <b>Application Specification</b>		
TITLE Minitek Pwr4.2 Crimp to Wire Connectors		PAGE 1 of 10	REVISION A
		AUTHORIZED BY Kenny Tai	DATE 2014/3/17
CLASSIFICATION <b>UNRESTRICTED</b>			

## 1.0 OBJECTIVE

This specification provides information and requirements regarding customer application of Minitek Pwr4.2 crimp to wire connectors. This specification is intended to provide general guidance for application process development. It is recognized that no single application process will work under all customer scenarios and that customers will develop their own application processes to meet their needs. However, if these application processes differ greatly from the one recommended, FCI cannot guarantee results.

## 2.0 SCOPE

This specification provides information and requirements regarding customer application of Minitek Pwr4.2 crimp to wire connectors.

## 3.0 GENERAL

This document is meant to be an application guide. If there is a conflict between the product drawings and specifications, the drawings take precedence.

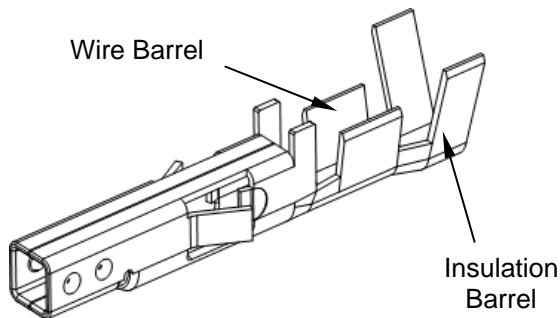

Receptacle Terminal 10127817 Series

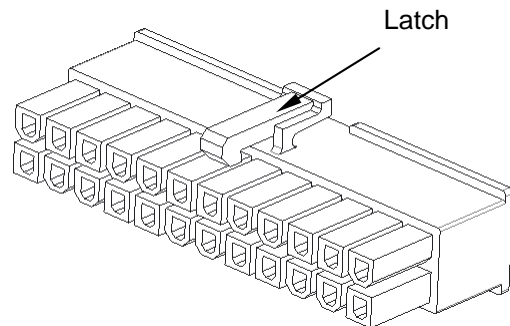

Receptacle HSG 10127815 Series

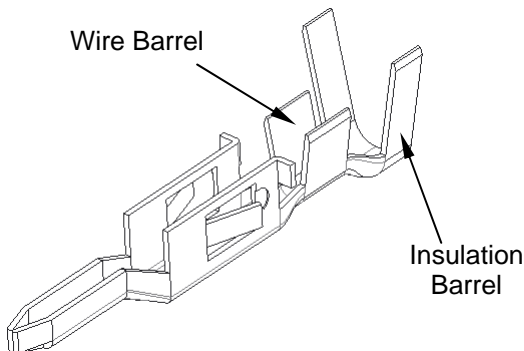

Plug Terminal 10127818 Series

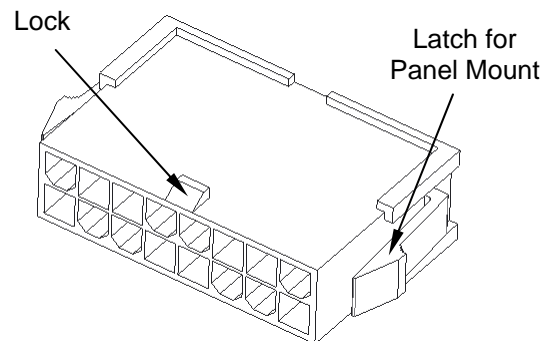

Panel Mount, Plug HSG  
10127816 series

NUMBER GS-20-401	TYPE <b>Application Specification</b>		
TITLE Minitek Pwr4.2 Crimp to Wire Connectors		PAGE 2 of 10	REVISION A
		AUTHORIZED BY Kenny Tai	DATE 2014/3/17
		CLASSIFICATION <b>UNRESTRICTED</b>	

#### 4.0 DRAWINGS AND APPLICABLE DOCUMENTS

- 4.1 FCI Product Specification: GS-12-1181
- 4.2 FCI Product Drawing: Latest version of: 10127815 (Receptacle HSG), 10127816 (Plug HSG); 10127817 (Receptacle crimp terminal), 10127818 (Plug crimp terminal)

Product drawings and **FCI's GS-XX-XXX** Product Specification are available at [www.fci.com](http://www.fci.com). In the event of a conflict between this application specification and the drawing, the drawing will take precedence. Customers are advised to refer to the latest revision level of FCI product drawings for appropriate details.

#### 5.0 APPLICATION REQUIREMENTS

The wires in Table 1 are the wiring information for use with crimp terminals 10127817 & 10127818.

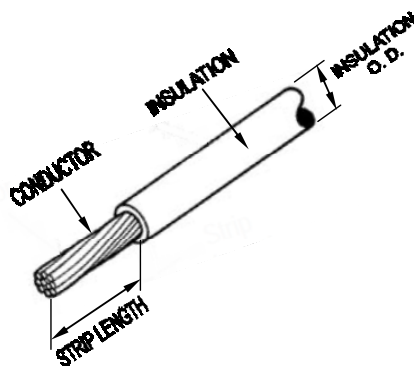

Table 1

Crimp Terminal Part Number	Applicable Wire Gauge (AWG)	Insulation Outside Diameter (mm)	Strip Length (mm)
10127817-XX2LF 10127818-XX2LF	AWG 28 ~ 24	1.8 max.	3 ~ 3.5
10127817-XX1LF 10127818-XX1LF	AWG 22 ~ 16	3.1 max.	3 ~ 3.5

#### 6.0 APPLICATION TOOLING

There are some commercial crimping tools available for crimping terminals. Select the models listed in Table 2:

Table 2: Crimping Tooling List

Tool Description	Tool P/ N and Model No.	Applicable Terminal
Ratched hand crimping tool	10129483-001LF (or equivalent model) (*)	10127817-XXXLF 10127818-XXXLF
Semi auto crimping machine	10129484-001LF (or equivalent model) Crimping die: To be designed per customer's request (**)	

\* Read the instructions before using these commercial crimping tool.

\*\* Depends on conductor dia. and insulation dia. of selected wire.

NUMBER GS-20-401	TYPE <b>Application Specification</b>		
TITLE Minitek Pwr4.2 Crimp to Wire Connectors		PAGE 3 of 10	REVISION A
		AUTHORIZED BY Kenny Tai	DATE 2014/3/17
		CLASSIFICATION <b>UNRESTRICTED</b>	



10129483-001LF

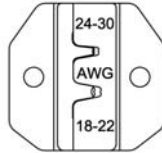

(Crimping Die)



10129484-001LF

## 7.0 APPLICATION PROCEDURE

- 7.1 Strip the wire (Table 1). Crimp wire and inserting to housing. No insertion tool is required. (Same for 10127817-XXXLF & 10127818-XXXLF).

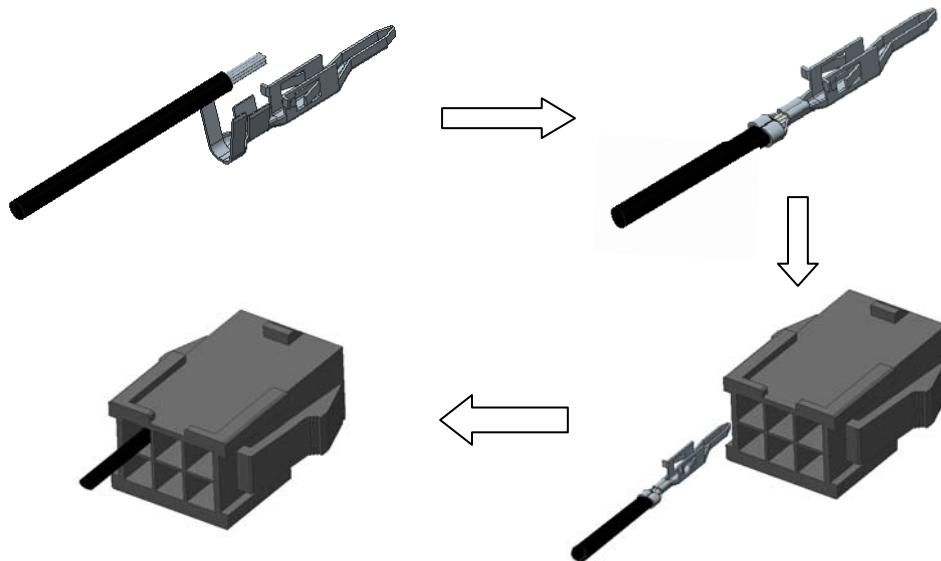

- 7.2 Make sure the stoppers on the terminals are always upwards for both rows: towards the lock (latch) of HSG. (Same for 10127817-XXXLF & 10127818-XXXLF)

NUMBER GS-20-401	TYPE Application Specification	FCI	
TITLE Minitek Pwr4.2 Crimp to Wire Connectors		PAGE 4 of 10	REVISION A
		AUTHORIZED BY Kenny Tai	DATE 2014/3/17
		CLASSIFICATION <b>UNRESTRICTED</b>	

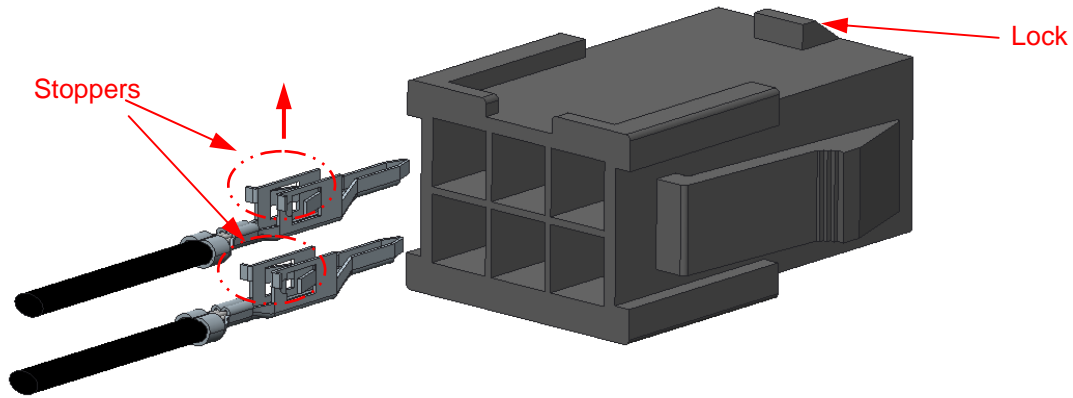

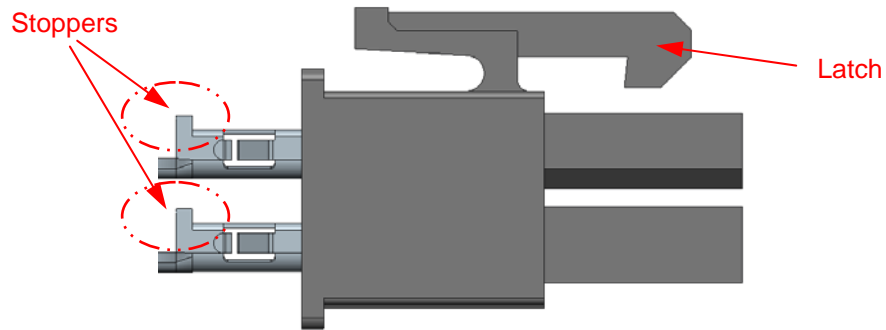

10127818 inserted to 10127816

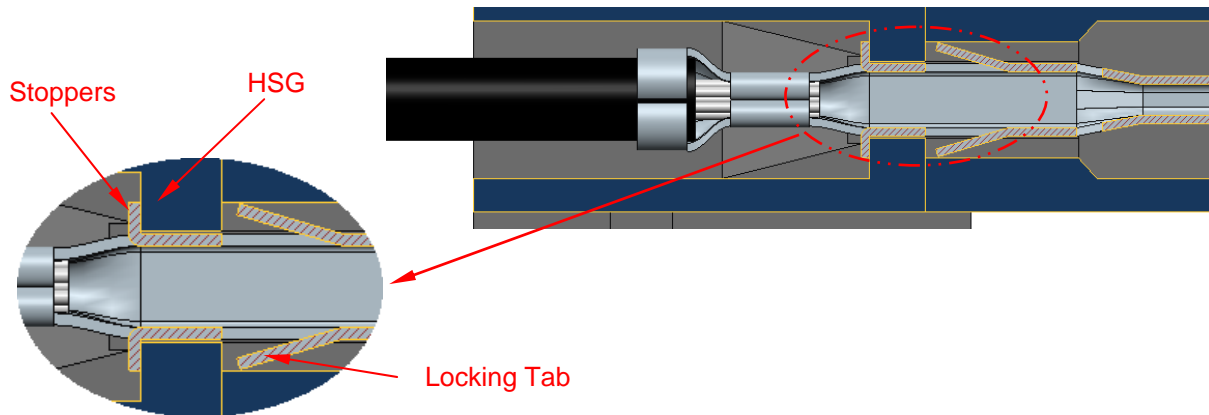

10127817 inserted to 10127815

7.3 Insert the terminal into HSG until stopped by HSG. Then locking tabs will be engaged the retention shoulder and prevent back out during mating. Pull back the wire slightly and ensure the terminal is fully seated on the HSG.



NUMBER GS-20-401	TYPE <b>Application Specification</b>		
TITLE Minitek Pwr4.2 Crimp to Wire Connectors	PAGE 5 of 10	REVISION A	
	AUTHORIZED BY Kenny Tai	DATE 2014/3/17	
CLASSIFICATION <b>UNRESTRICTED</b>			

## 8.0 POST-APPLICATION INSPECTION PROCEDURES

### 8.1 Crimp height and width measurement:

8.1.1 Use Crimp Height Type Micrometers to measure crimping height.

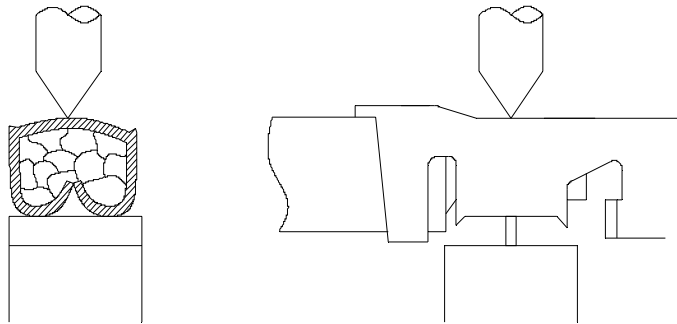

8.2 Required crimping dimensions, crimp height and width for different wire AWG are defined in Table 3 & Table 4.

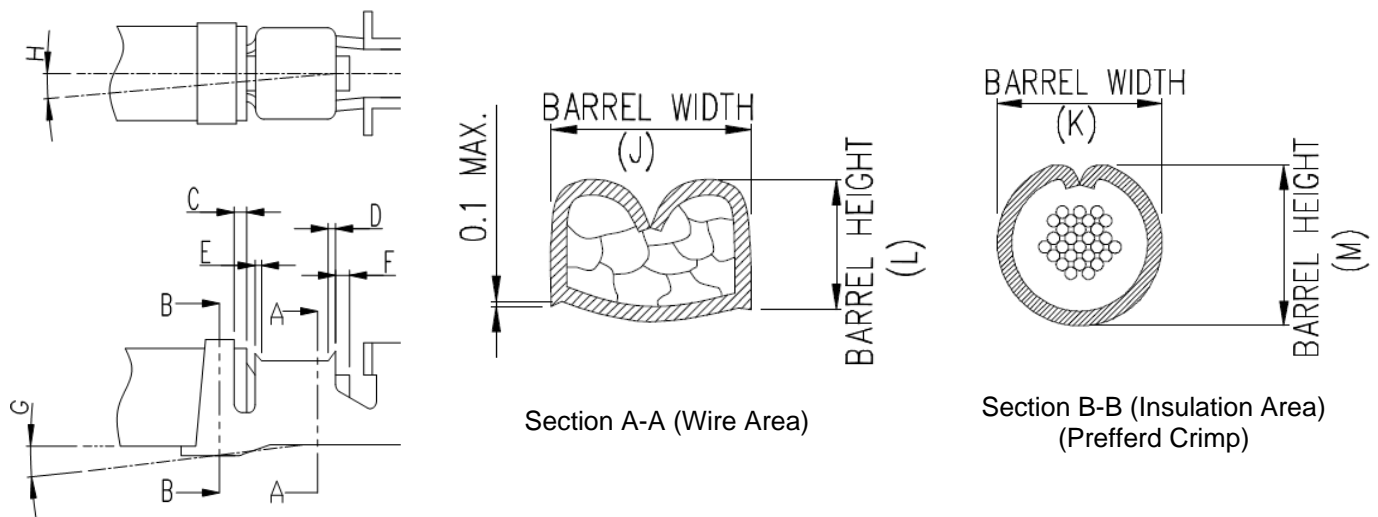

NUMBER GS-20-401	TYPE <b>Application Specification</b>		
TITLE Minitek Pwr4.2 Crimp to Wire Connectors		PAGE 6 of 10	REVISION A
		AUTHORIZED BY Kenny Tai	DATE 2014/3/17
		CLASSIFICATION <b>UNRESTRICTED</b>	

Table 3 (unit: mm)

Item		Requirement	Note
Insulation position	C	0.5 mm (Ref.)	Insulation and wire should be visual in this area
Front bell mouth	D	0.4 mm max.	
Rear bell mouth	E	0.4 mm max.	
Extruded wire length	F	0.8 max.	
Bend up / down	G	±3° max.	
Bend right / left	H	±3° max.	

Table 4 (unit: mm)

Crimping Width & Height (mm)		AWG 16	AWG 18	AWG 20	AWG 22	AWG 24	AWG 26	AWG 28
Crimping Width (Wire barrel)	J	2.00	1.95	1.90	1.85	1.80	1.70	1.60
Crimping Width (Insulation barrel)	K	3.20	2.90	2.70	2.40	2.20	2.00	1.90
Crimping Height (Wire barrel)	L	1.60	1.50	1.30	1.20	1.10	1.00	0.90
Crimping Height (Insulation barrel)	M	3.00	2.50	2.30	2.10	2.00	1.90	1.70

\* When using hand crimping tool, crimping height K & M in this table are reference only. Because the range of wires, strands, insulation OD will affect the actual crimping height.

\*\* Pullout force should be performed to check the hand crimping tool.

### 8.3 Pullout force measurement:

8.3.1 After crimping, pullout force measurement should be applied to ensure the performance.

8.3.2 Follow test procedure of GS-12-1181. Apply an axial pullout force on the wire at a rate of  $25 \pm 6$  mm.

8.3.3 Pullout force should not be less the those listed in Table 5.

Table 5 (unit: N)

Wire AWG	AWG 16	AWG 18	AWG 20	AWG 22	AWG 24	AWG 26	AWG 28
Wire Pullout Force	88	88	59	39	29	19	9.8

8.4 V  
i

sual Inspection:

8.4.1 No damage, deformation on locking tabs, contact area or other portion of the terminals.

8.4.2 Insulation should not be crimped into wire barrel.

8.4.3 Wire should not be cut-off and insulation should not be broken after crimping process.

NUMBER GS-20-401	TYPE <b>Application Specification</b>		
TITLE Minitek Pwr4.2 Crimp to Wire Connectors		PAGE 7 of 10	REVISION A
		AUTHORIZED BY Kenny Tai	DATE 2014/3/17
CLASSIFICATION <b>UNRESTRICTED</b>			

## 9.0 REPAIR TOOLING

The tool needed for extracting terminals from HSG is defined in Table 6:

Table 6

Tool P/N	Tool Description	Applicable Terminal P/N
FCI 10129274-042LF	Terminal extract tool	10127817 & 10127818 series

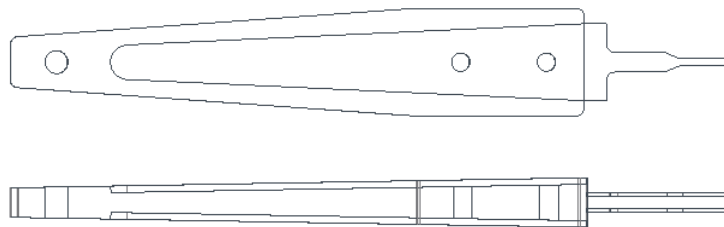

## 10.0 REPAIR / REMOVAL PROCEDURE

10.1 Use the extract tool 10129274-042LF to replace or repair individual terminal which is in the HSG.

10.1.1 Insert the extract tool into HSG.

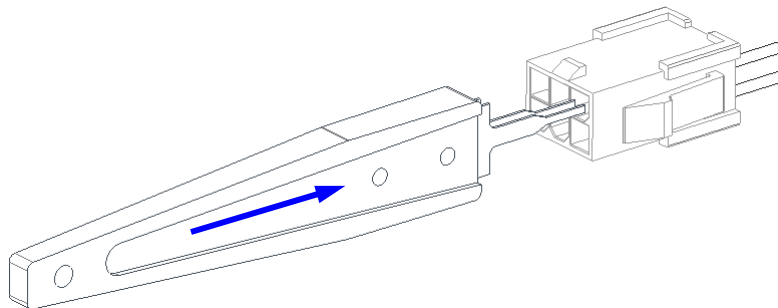

10.1.2 Depress locking tabs on the terminals and pull out terminal from HSG.

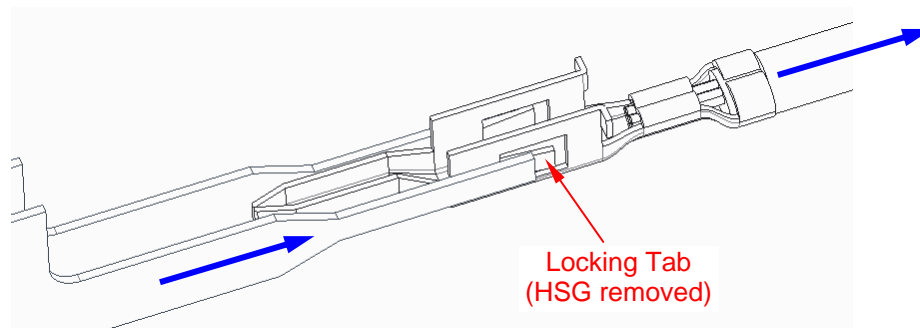

NUMBER GS-20-401	TYPE <b>Application Specification</b>		
TITLE Minitek Pwr4.2 Crimp to Wire Connectors		PAGE 8 of 10	REVISION A
		AUTHORIZED BY Kenny Tai	DATE 2014/3/17
CLASSIFICATION <b>UNRESTRICTED</b>			

10.2 To reuse the removed terminal, need to reset the locking tabs before the terminal is inserted into the HSG.  
(not recommend)

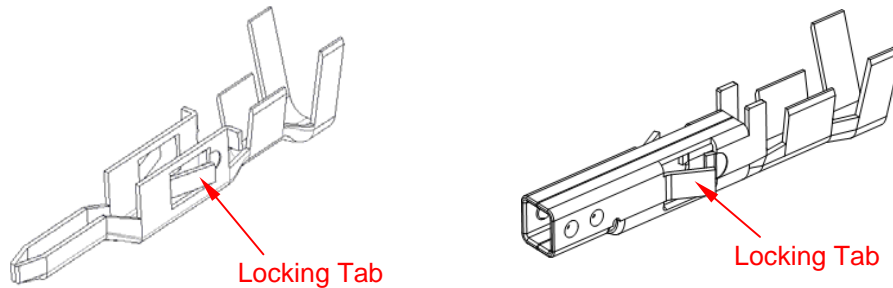

## 11.0 OTHERS

### 11.1 Panel mount application

11.1.1 Applicable for header wire connector, HSG 10127816 series + Terminal 10127818 series

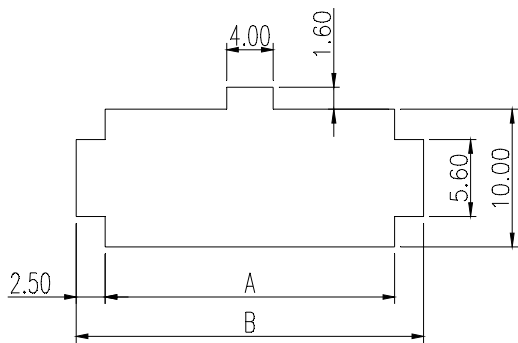

Opening for panel mount application  
Recommended max. panel thickness: 2.54mm

PART NUMBER	POS.	A	B
10127816-02LF	2	5.8	10.8
10127816-04LF	4	10.0	15.0
10127816-04LF	6	14.2	19.2
10127816-08LF	8	18.4	23.4
10127816-10LF	10	22.6	27.6
10127816-12LF	12	26.8	31.8
10127816-14LF	14	31.0	36.0
10127816-16LF	16	35.2	40.2
10127816-18LF	18	39.4	44.4
10127816-20LF	20	43.6	48.6
10127816-22LF	22	47.8	52.8
10127816-24LF	24	52.0	57.0

11.1.2 When header HSG (10127816 series) is assembled with crimped terminals (10127818 series), insert it to the panel until it is stopped on the panel. No mounting tool is required.

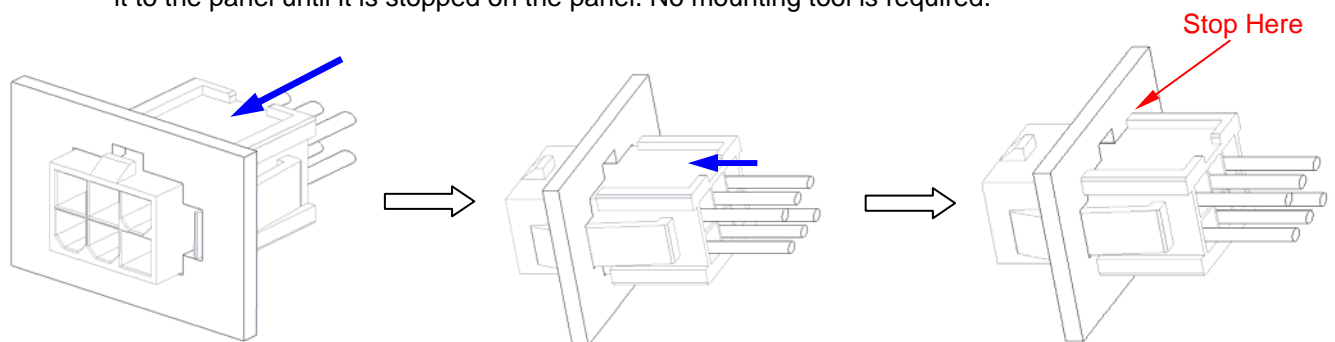



NUMBER GS-20-401	TYPE <b>Application Specification</b>		
TITLE Minitek Pwr4.2 Crimp to Wire Connectors		PAGE 9 of 10	REVISION A
		AUTHORIZED BY Kenny Tai	DATE 2014/3/17
CLASSIFICATION <b>UNRESTRICTED</b>			

11.2 Mating Pairs: Receptacle wire connector 10127815, with receptacle crimping terminals 10127817 inserted, can mate with the following FCI wire / board connectors:

- 11.2.1 Plug wire connector 10127816 with plug crimping terminals 10127818 inserted;
- 11.2.2 Right angle board connector 10127819;
- 11.2.3 Vertical board connector 10127820;

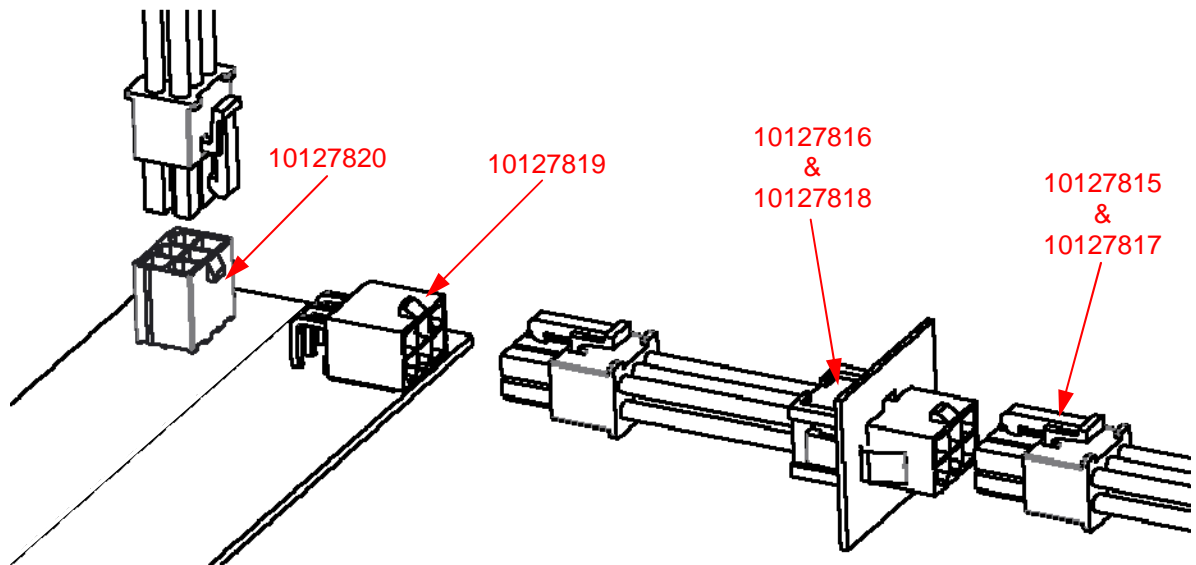

11.3 During connectors mating, make sure latch on the receptacle wire connector is fully secured to the lock on plug wire connector or board connectors.

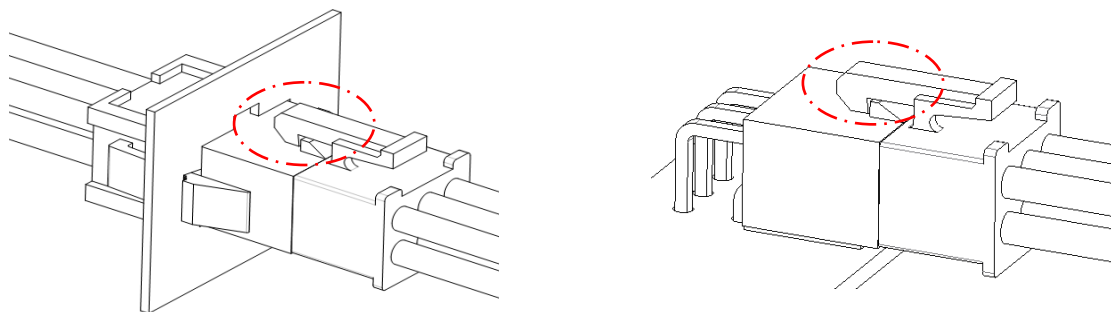

NUMBER <b>GS-20-401</b>	TYPE <b>Application Specification</b>		
TITLE <b>Minitex Pwr4.2 Crimp to Wire Connectors</b>		PAGE <b>10 of 10</b>	REVISION <b>A</b>
		AUTHORIZED BY <b>Kenny Tai</b>	DATE <b>2014/3/17</b>
CLASSIFICATION <b>UNRESTRICTED</b>			

**12.0 RECORD RETENTION**

REV	PAGE	DESCRIPTION	EC#	DATE
A	All	New Release		2014/3/17