

THIS DRAWING IS UNPUBLISHED. RELEASED FOR PUBLICATION  
 © COPYRIGHT 19 BY AMP INCORPORATED. ALL RIGHTS RESERVED.

| Loc |     | DIST  |  | REVISIONS |     |      |  |
|-----|-----|---|--|-----------|-----|------|--|
| P   | LTR | DESCRIPTION                                       |  | DATE      | DWN | APVD |  |
|     | 0   | RELEASED PER NPR 5380                             |  | 07/11/95  | -   | -    |  |
|     | A   | ADDED -1 THRU -7, -11 & -12<br>PER EC 0020-181-96 |  | 22 FEB 96 | DH  | RK   |  |
|     | B   | REV PER EC 0410-103-96                            |  | 15 FEB 97 | CR  | JGH  |  |

11.81±0.25  
[.465±.010]

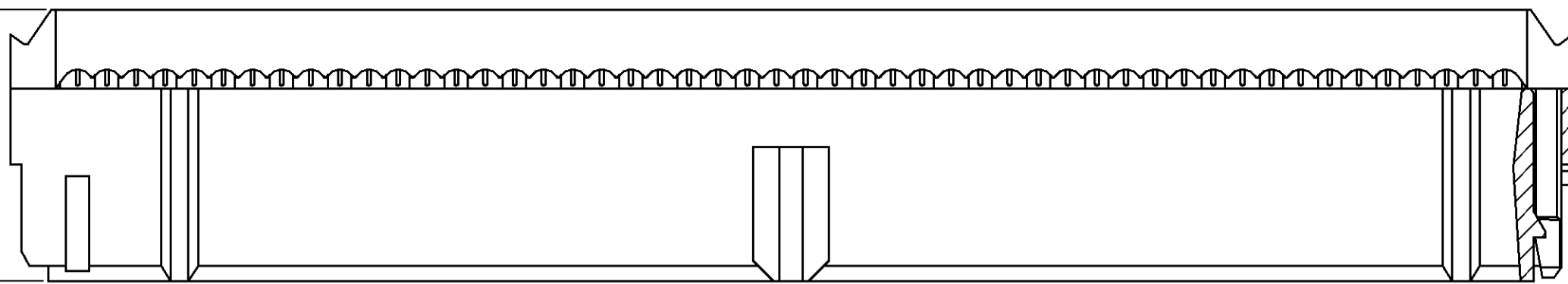

TERMINATED VIEW

- 1 THERMOPLASTIC, BLACK, UL 94V-0 RATED.
- 2 COPPER ALLOY
- 3 0.38µm [.000015] MIN GOLD ON CONTACT AREA,  
0.76µm [.000030] MIN BRIGHT TIN-LEAD ON TERMINATION END,  
ALL OVER NICKEL.

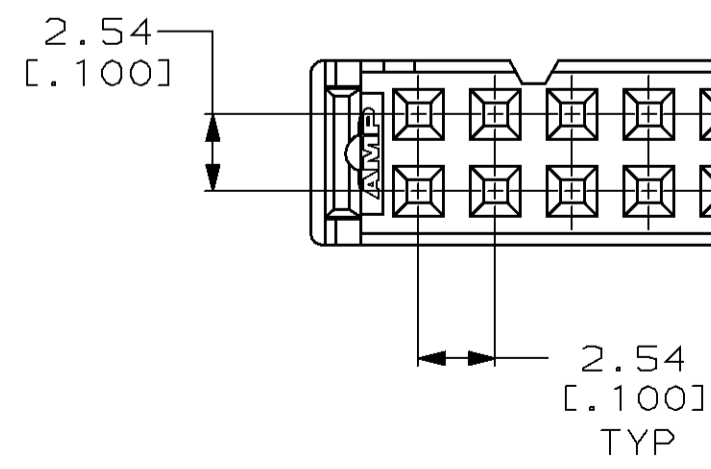
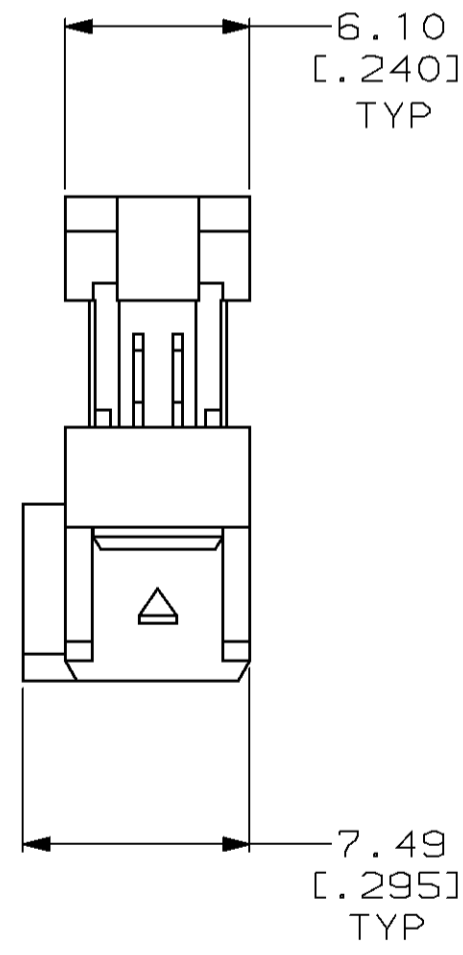
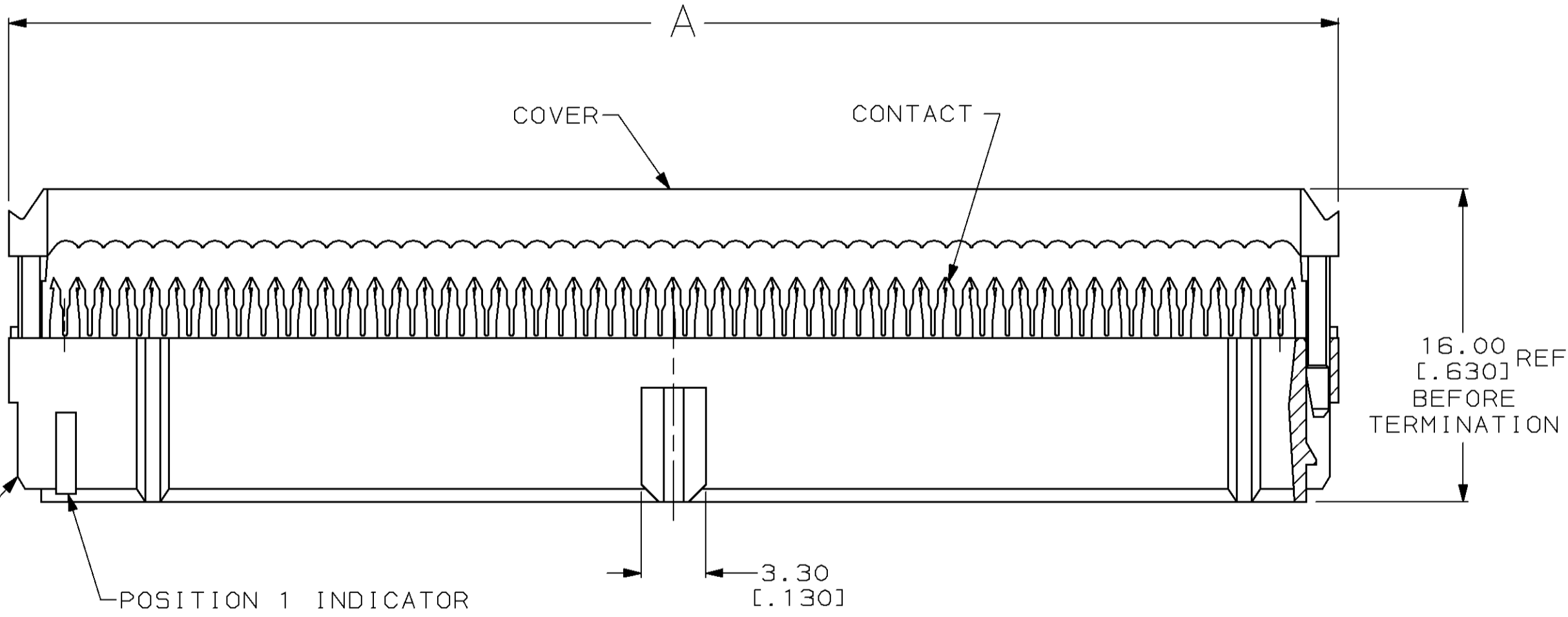
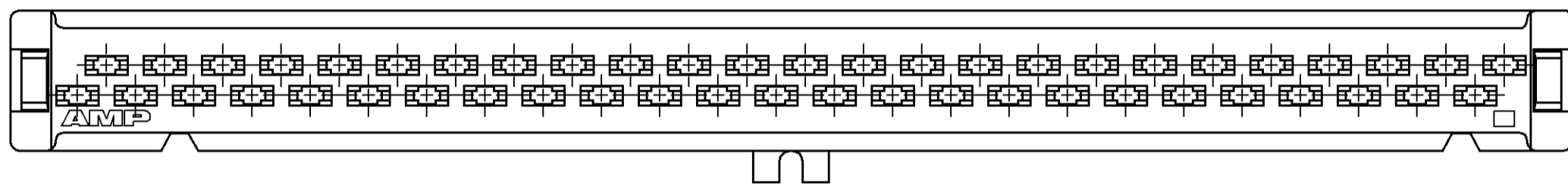

|               |            |            |
|---------------|------------|------------|
| 85.85 [3.380] | 64         | 1-111918-2 |
| 80.77 [3.180] | 60         | 1-111918-1 |
| 68.07 [2.680] | 50         | 1-111918-0 |
| 55.37 [2.180] | 40         | 111918-9   |
| 47.75 [1.880] | 34         | 111918-8   |
| 42.67 [1.680] | 30         | 111918-7   |
| 37.59 [1.480] | 26         | 111918-6   |
| 35.05 [1.380] | 24         | 111918-5   |
| 29.97 [1.180] | 20         | 111918-4   |
| 24.89 [.980]  | 16         | 111918-3   |
| 22.35 [.880]  | 14         | 111918-2   |
| 17.27 [.680]  | 10         | 111918-1   |
| A             | NO OF POSN | PART NO    |

THIS DRAWING IS A CONTROLLED DOCUMENT FOR AMP INCORPORATED. IT IS SUBJECT TO CHANGE AND THE CONTROLLING ENGINEERING ORGANIZATION SHOULD BE CONTACTED FOR THE LATEST REVISION.

|   |  |  |  |
|---|--|--|--|
| DIMENSIONS:<br>mm [INCHES]                    | TOLERANCES UNLESS OTHERWISE SPECIFIED:<br>0 PLC ±<br>1 PLC ±<br>2 PLC ±0.13 [.005]<br>3 PLC ±<br>4 PLC ±<br>ANGLES ±<br>FINISH ± | DWN<br>K.FOLTZ 07/11/95<br>CHK<br>R.STONE 07/12/95<br>APVD<br>J.STINE 07/13/95 | AMP Incorporated<br>Harrisburg, PA 17105-3608  |
| MATERIAL<br>HOUSING & COVER: 1<br>CONTACTS: 2 | CONTACTS: 3  | PRODUCT SPEC<br>108-1529<br>APPLICATION SPEC<br>114-40005<br>WEIGHT<br>-       | NAME<br>RECEPTACLE ASSEMBLY,<br>CENTER & MILITARY<br>POLARIZATION, ECONO-LATCH<br>SIZE<br>A2<br>CAGE CODE<br>00779<br>DRAWING NO<br>C-111918 |
| CUSTOMER DRAWING                              |  | SCALE<br>4:1   | SHEET<br>1 OF 1<br>REV<br>B  |