



Main

| | |
|------------------------------------|--|
| Range of product | Altivar Machine ATV320 |
| Product or component type | Variable speed drive |
| Product specific application | Complex machines |
| Device short name | ATV320 |
| Format of the drive | Book |
| Product destination | Synchronous motors Asynchronous motors |
| EMC filter | Class C2 EMC filter integrated |
| IP degree of protection | IP20 conforming to EN/IEC 61800-5-1 |
| Degree of protection | UL type 1 with UL type 1 conformity kit |
| Type of cooling | Fan |
| Network number of phases | 3 phases |
| [Us] rated supply voltage | 380...500 V (- 15...10 %) |
| Supply frequency | 50...60 Hz (- 5...5 %) |
| Motor power kW | 11 kW for heavy duty |
| Motor power hp | 15 hp for heavy duty |
| Line current | 36.6 A at 380 V for heavy duty 25.6 A at 500 V for heavy duty |
| Prospective line I _{sc} | <= 22 kA |
| Apparent power | 22.2 kVA at 500 V for heavy duty |
| Continuous output current | 27.7 A at 4 kHz for heavy duty |
| Maximum transient current | 41.6 A during 60 s for heavy duty |
| Asynchronous motor control profile | Flux vector control without sensor, standard Voltage/Frequency ratio, 2 points Voltage/Frequency ratio - Energy Saving, quadratic U/f Flux vector control without sensor - Energy Saving Voltage/Frequency ratio, 5 points |
| Synchronous motor control profile | Vector control without sensor |
| Speed drive output frequency | 0.1...599 Hz |
| Nominal switching frequency | 4 kHz |
| Switching frequency | 4...16 kHz with current derating 2...16 kHz adjustable |
| Safety function | STO (safe torque off) SIL 3 SS1 (safe stop 1) |

Disclaimer: This documentation is not intended as a substitute for and is not to be used for determining suitability or reliability of these products for specific user applications

SMS (safe maximum speed)
 SLS (safe limited speed)
 GDL (guard door locking)

| | |
|-----------------------------|---|
| Communication port protocol | Modbus CANopen |
| Option card | Communication module: CANopen daisy chain RJ45 Communication module: CANopen SUB-D 9 Communication module: CANopen open style terminal block Communication module: EtherCAT RJ45 Communication module: DeviceNet Communication module: Ethernet/IP Communication module: Profibus DP V1 Communication module: Profinet Communication module: Ethernet Powerlink |

Complementary

| | |
|-------------------------------------|---|
| Output voltage | \leq power supply voltage |
| Permissible temporary current boost | 1.5 x I _n during 60 s for heavy duty |
| Speed range | 1...100 with asynchronous motor in open-loop mode |
| Speed accuracy | +/- 10 % of nominal slip 0.2 T _n to T _n |
| Torque accuracy | +/- 15 % |
| Transient overtorque | 170...200 % of nominal motor torque |
| Braking torque | \leq 170 % with braking resistor during 60 s |
| Regulation loop | Adjustable PID regulator |
| Motor slip compensation | Adjustable 0...300 % Automatic whatever the load Not available in voltage/frequency ratio (2 or 5 points) |
| Acceleration and deceleration ramps | S Linear CUS Deceleration ramp automatic stop DC injection Ramp switching Deceleration ramp adaptation U |
| Braking to standstill | By DC injection |
| Protection type | Drive: thermal protection Drive: overcurrent between output phases and earth Drive: input phase breaks Drive: overheating protection Drive: short-circuit between motor phases |
| Frequency resolution | Display unit: 0.1 Hz Analog input: 0.012/50 Hz |
| Electrical connection | Control, screw terminal: 0.5...1.5 mm ² AWG 20...AWG 16 Motor/Braking resistor, screw terminal: 6...16 mm ² AWG 8...AWG 6 Power supply, screw terminal: 10...16 mm ² AWG 8...AWG 6 |
| Connector type | 1 RJ45 for Modbus/CANopen on front face |
| Physical interface | 2-wire RS 485 for Modbus |
| Transmission frame | RTU for Modbus |
| Transmission rate | 4.8, 9.6, 19.2, 38.4 kbit/s for Modbus 50 kbps, 125 kbps, 250 kbps, 500 kbps, 1 Mbps for CANopen |
| Data format | 8 bits, configurable odd, even or no parity for Modbus |
| Type of polarization | No impedance for Modbus |
| Number of addresses | 1...247 for Modbus 1...127 for CANopen |
| Method of access | Slave for CANopen |
| Supply | Internal supply for reference potentiometer (1 to 10 kOhm): 10.5 V DC (+/- 5 %) current \leq 10 mA (overload and short-circuit protection) |
| Local signalling | 1 LED green for CANopen run 1 LED red for CANopen error 1 LED red for drive fault 1 LED red for drive voltage |
| Width | 180 mm |

| | |
|------------------------------------|--|
| Height | 330 mm 404 mm with EMC plate |
| Depth | 232 mm |
| Product weight | 8.7 kg |
| Analogue input number | 3 |
| Analogue input type | Voltage (AI1): 0...10 V DC, impedance 30000 Ohm, resolution 10 bits Bipolar differential voltage (AI2): +/- 10 V DC, impedance 30000 Ohm, resolution 10 bits Current (AI3): 0...20 mA (or 4-20 mA, x-20 mA, 20-x mA or other patterns by configuration), impedance 250 Ohm, resolution 10 bits |
| Discrete input number | 7 |
| Discrete input type | Programmable (sink/source) (DI1...DI4): 24...30 V DC: level 1 PLC Programmable as pulse input 20 kpps (DI5): 24...30 V DC: level 1 PLC Switch-configurable PTC probe (DI6): 24...30 V DC Safe torque off (STO): 24...30 V DC, impedance 1500 Ohm |
| Discrete input logic | Negative logic (sink): : DI1...DI6, > 19 V (state 0) < 13 V (state 1) Positive logic (source): : DI1...DI6, < 5 V (state 0) > 11 V (state 1) |
| Analogue output number | 1 |
| Analogue output type | Software-configurable current (AQ1): 0...20 mA, impedance 800 Ohm, resolution 10 bits Software-configurable voltage (AQ1): 0...10 V, impedance 470 Ohm, resolution 10 bits |
| Sampling duration | Analog input (AI1, AI2, AI3): 2 ms Analog output (AQ1): 2 ms |
| Accuracy | Analog input AI1, AI2, AI3: +/- 0.2 % for a temperature of -10...60 °C Analog input AI1, AI2, AI3: +/- 0.5 % for a temperature of 25 °C Analog output AQ1: +/- 1 % for a temperature of 25 °C Analog output AQ1: +/- 2 % for a temperature of -10...60 °C |
| Linearity error | Analog input (AI1, AI2, AI3): +/- 0.2...0.5 % of maximum value Analog output (AQ1): +/- 0.3 % |
| Discrete output number | 3 |
| Discrete output type | Configurable relay logic NO/NC (R1A, R1B, R1C): electrical durability 100000 cycles Configurable relay logic NO (R2A, R2B): electrical durability 100000 cycles Logic (LO) |
| Refresh time | Logic input (DI1...DI6): 8 ms (+/- 0.7 ms) Relay output (R1A, R1B, R1C): 2 ms Relay output (R2A, R2C): 2 ms |
| Minimum switching current | Relay output (R1, R2): 5 mA at 24 V DC |
| Maximum switching current | Relay output (R1) on resistive load (cos phi = 1: 3 A at 250 V AC Relay output (R1) on resistive load (cos phi = 1: 4 A at 30 V DC Relay output (R1, R2) on inductive load (cos phi = 0.4: 2 A at 250 V AC Relay output (R1, R2) on inductive load (cos phi = 0.4: 2 A at 30 V DC Relay output (R2) on resistive load (cos phi = 1: 5 A at 250 V AC Relay output (R2) on resistive load (cos phi = 1: 5 A at 30 V DC |
| Specific application | Machinery |
| Discrete and process manufacturing | Hoisting self erecting Material handling carousel Material handling conveyor Material handling lifting platform Material handling palletizers - medium performance Material handling transfer table Material handling turn table Material working (wood, ceramic, stone, pvc, metal) cutting - medium accuracy Material working (wood, ceramic, stone, pvc, metal) drilling Material working (wood, ceramic, stone, pvc, metal) saw Packaging bagging Packaging feed conveyor low performance Packaging filling bottles - intermittent operation Packaging linear labeling Packaging other application Packaging stretching wrapping Packaging tray take Textile knitting Textile printing machines Textile spinning Washing machines car Washing machines other application Hoisting standard crane - travelling or trolley |
| Power range | 7...11 kW 380...440 V 3 phases 7...11 kW 480...500 V 3 phases |

| | |
|--------------------|----------------------|
| Motor starter type | Variable speed drive |
|--------------------|----------------------|

Environment

| | |
|---------------------------------------|---|
| Isolation | Between power and control terminals |
| Insulation resistance | > 1 mOhm at 500 V DC for 1 minute to earth |
| Noise level | 58 dB conforming to 86/188/EEC |
| Power dissipation in W | 403 W (fan) at 380 V, 4 kHz |
| Operating position | Vertical +/- 10 degree |
| Electromagnetic compatibility | Conducted radio-frequency immunity test conforming to IEC 61000-4-6 level 3 Electrical fast transient/burst immunity test conforming to IEC 61000-4-4 level 4 Electrostatic discharge immunity test conforming to IEC 61000-4-2 level 3 Radiated radio-frequency electromagnetic field immunity test conforming to IEC 61000-4-3 level 3 Voltage dips and interruptions immunity test conforming to IEC 61000-4-11 1.2/50 µs - 8/20 µs surge immunity test conforming to IEC 61000-4-5 level 3 |
| Pollution degree | 2 conforming to EN/IEC 61800-5-1 |
| Vibration resistance | 1.5 mm peak to peak (f = 3...13 Hz) conforming to EN/IEC 60068-2-6 1 gn (f = 13...200 Hz) conforming to EN/IEC 60068-2-6 |
| Shock resistance | 15 gn during 11 ms conforming to EN/IEC 60068-2-27 |
| Relative humidity | 5...95 % without condensation conforming to IEC 60068-2-3 5...95 % without dripping water conforming to IEC 60068-2-3 |
| Ambient air temperature for operation | -10...50 °C without derating 50...60 °C with derating factor |
| Ambient air temperature for storage | -25...70 °C |
| Operating altitude | <= 1000 m without derating 1000...2000 m with current derating 1 % per 100 m |
| Standards | EN/IEC 61800-3 EN/IEC 61800-5-1 EN 55011 class A group 1 EN 61800-3 environment 1 category C2 EN 61800-3 environment 2 category C2 |
| Product certifications | RCM CSA EAC NOM 117 UL |
| Marking | CE |

Offer Sustainability

| | |
|--------------------------|---|
| Sustainable offer status | Not Green Premium product |
| RoHS (date code: YYWW) | Compliant - since 1614 - Schneider Electric declaration of conformity Schneider Electric declaration of conformity |
| REACH | Reference not containing SVHC above the threshold Reference not containing SVHC above the threshold |

Dimensions

- (1) Right view
- (2) Front view
- (3) Right view with EMC plate
- (4) Front view with EMC plate

Mounting and Clearance

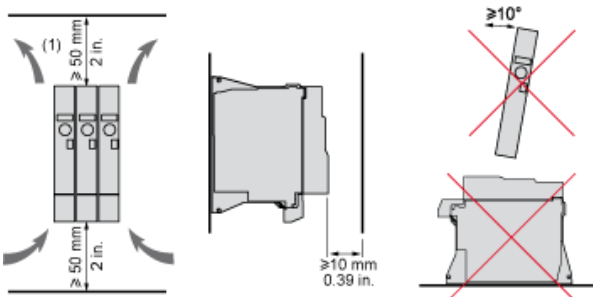

(1) Minimum value corresponding to thermal constraints.

Connection Diagrams

Diagram with Line Contactor

Connection diagrams conforming to standards EN 954-1 category 1 and IEC/EN 61508 capacity SIL1, stopping category 0 in accordance with standard IEC/EN 60204-1.

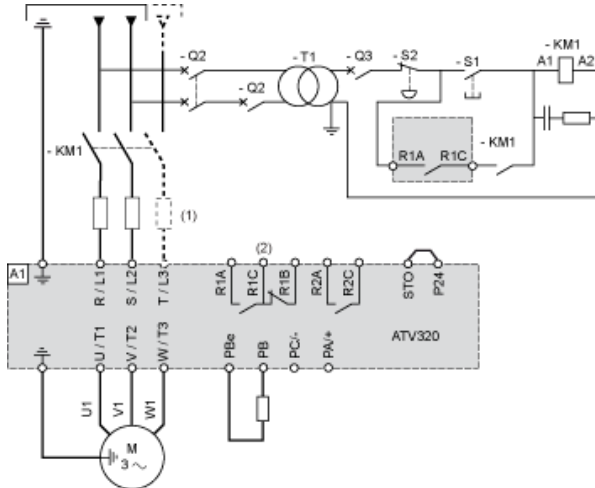

- (1) Line choke (if used)
- (2) Fault relay contacts, for remote signaling of drive status

Diagram with Switch Disconnect

Connection diagrams conforming to standards EN 954-1 category 1 and IEC/EN 61508 capacity SIL1, stopping category 0 in accordance with standard IEC/EN 60204-1.

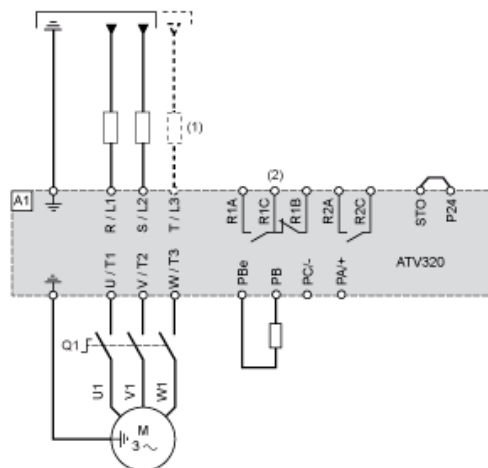

- (1) Line choke (if used)
- (2) Fault relay contacts, for remote signaling of drive status

Control Connection Diagram in Source Mode

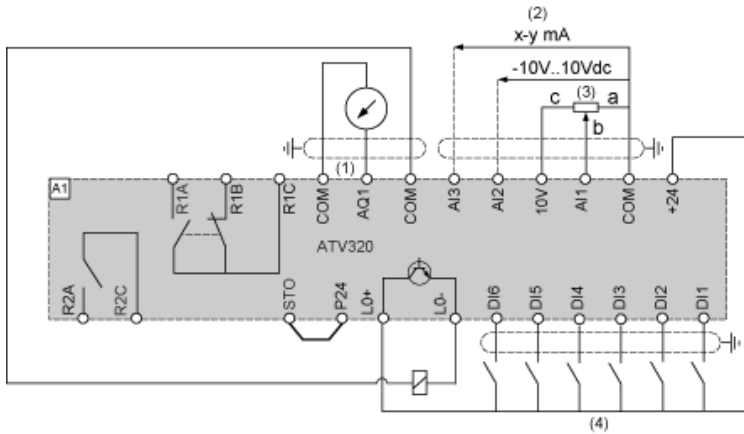

- (1) Analog output
- (2) Analog inputs
- (3) Reference potentiometer (10 kOhm maxi)
- (4) Digital inputs

Digital Inputs Wiring

The logic input switch (SW1) is used to adapt the operation of the logic inputs to the technology of the programmable controller outputs. Switch SW1 set to "Source" position and use of the output power supply for the DIs.

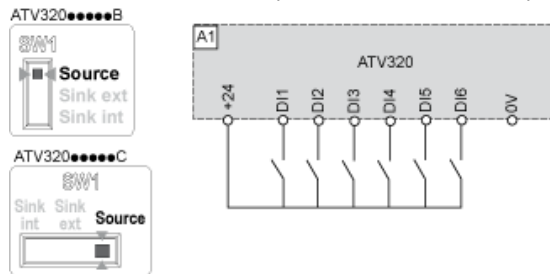

Switch SW1 set to "Source" position and use of an external power supply for the DIs.

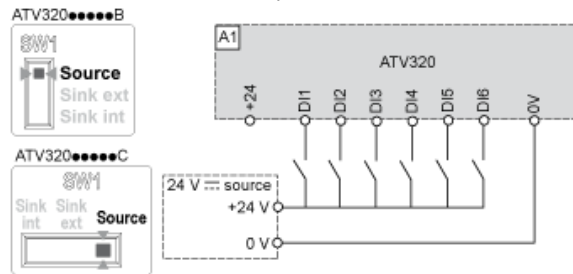

Switch SW1 set to "Sink Int" position and use of the output power supply for the DIs.

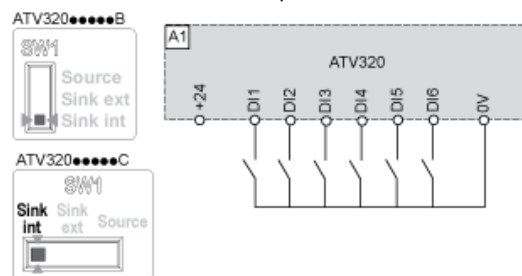

Switch SW1 set to "Sink Ext" position and use of an external power supply for the DIs.

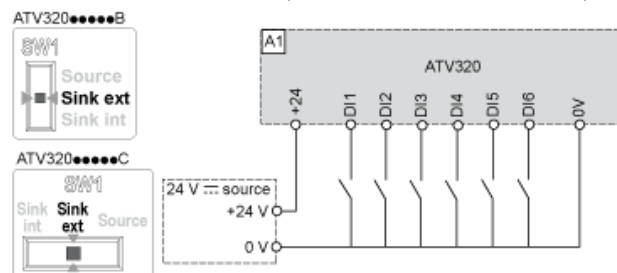

Derating Curves

Derating curve for the nominal drive current (I_n) as a function of temperature and switching frequency (SF).

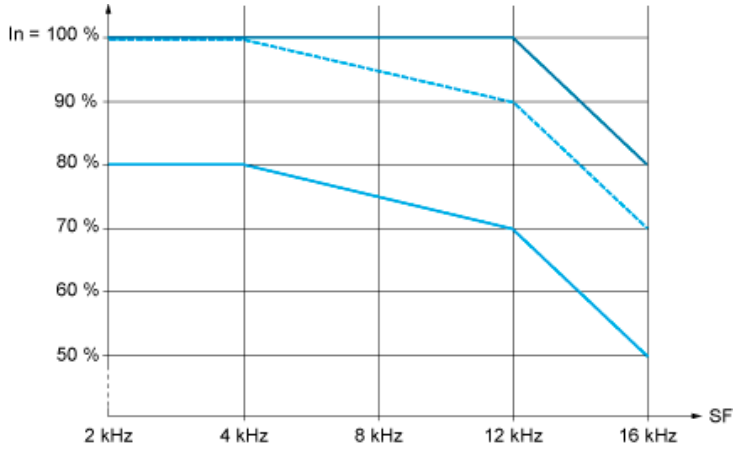

40 °C (104 °F) - Mounting type A, B and C
50 °C (122 °F) - Mounting type A, B and C
60 °C (140 °F) - Mounting type B and C

In : Nominal Drive Current
SF : Switching Frequency

Our Proposal: Circuit Breaker + Contactor + Drive for Motor Power 11 kW and 380 VAC

| Motor power (kW) | ICU (kA) | Breaker | Contactor (*) | Motor Starter |
|------------------|----------|---|---------------|---------------|
| 11 | 50 |  GV3L40 | LC1D25P7 | ATV320D11N4B |

Non contractual pictures.

(*) You can select the contactor proposed or variants. Please consider examples hereafter or follow the link to the complete offer.

| Motor power kW | Coil voltage VAC - 50/60 Hz | 24 | 48 | 110 | 115 | 220 | 230 | 400 | Other |
|----------------|-----------------------------|----|----|-----|-----|-----|-----|-----|----------------|
| 11 | LC1D25 .. | B7 | E7 | F7 | FE7 | M7 | P7 | V7 | Complete Offer |

| Motor power kW | Coil voltage VDC | 24 | 48 | 110 | 125 | 220 | 230 | Other |
|----------------|------------------|----|----|-----|-----|-----|-----|----------------|
| 11 | LC1D25 .. | BD | ED | - | - | - | - | Complete Offer |

| Motor power kW | Coil voltage Low Consumption VDC - U 0.8...1.25 | 24 | 110 | Other |
|----------------|---|----|-----|----------------|
| 11 | LC1D25 .. | BL | FL | Complete Offer |