

## Leaded Varistors

### EnergetiQ Series

#### Construction

- Square varistor element, leaded
- Coating: epoxy resin, flame-retardant to UL 94 V-0
- Terminals: tinned copper wire

#### Features

- High-EnergetiQ series Q14/Q20
- Maximum load capacity at minimum component height
- PSpice models

#### Approvals

- UL, CSA
- CECC

#### Taping

- For ordering information see page 206 ff, chapter “Leaded Varistors: Taping”

#### Type designation

Detailed description of coding system on page 39, chapter “General Technical Information”

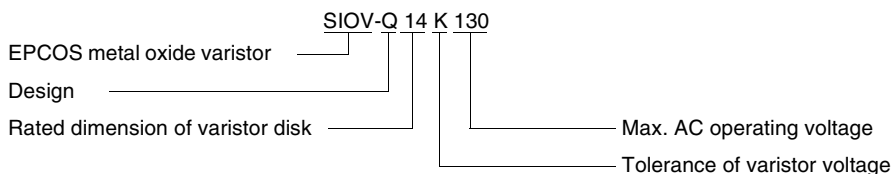

#### General technical data

Climatic category	40/85/56	in accordance with IEC 60068-1
LCT	- 40 °C	
UCT	+ 85 °C	
Damp heat, steady state (93 % r.h., 40 °C)	56 days	in accordance with IEC 60068-2-3
Operating temperature	- 40 ... + 85 °C	in accordance with CECC 42 000
Storage temperature	- 40 ... + 125 °C	
Electric strength	≥ 2,5 kV <sub>RMS</sub>	in accordance with CECC 42 000
Insulation resistance	≥ 10 MΩ	in accordance with CECC 42 000
Response time	< 25 ns	

**Leaded Varistors**
**EnergetiQ Series**
**Maximum ratings** ( $T_A = 85\text{ °C}$ )

Type (untaped) SIOV-	Ordering code	$V_{RMS}$ V	$V_{DC}$ V	$i_{max}$ 8/20 $\mu$ s A	$W_{max}$ (2 ms) J	$P_{max}$ W
Q14K130	B72214Q0131K101	130	170	8000	75	0,80
Q14K140	B72214Q0141K101	140	180	8000	80	0,80
Q14K150	B72214Q0151K101	150	200	8000	85	0,80
Q14K175	B72214Q0171K101	175	225	8000	100	0,80
Q14K210	B72214Q0211K101	210	270	8000	115	0,80
Q14K230	B72214Q0231K101	230	300	8000	130	0,80
Q14K250	B72214Q0251K101	250	320	8000	140	0,80
Q14K275	B72214Q0271K101	275	350	8000	150	0,80
Q14K300	B72214Q0301K101	300	385	8000	175	0,80
Q14K320	B72214Q0321K101	320	420	8000	185	0,80
Q20K130	B72220Q0131K101	130	170	15000	100	1,20
Q20K140	B72220Q0141K101	140	180	15000	110	1,20
Q20K150	B72220Q0151K101	150	200	15000	120	1,20
Q20K175	B72220Q0171K101	175	225	15000	135	1,20
Q20K210	B72220Q0211K101	210	270	15000	165	1,20
Q20K230	B72220Q0231K101	230	300	15000	180	1,20
Q20K250	B72220Q0251K101	250	320	15000	195	1,20
Q20K275	B72220Q0271K101	275	350	15000	215	1,20
Q20K300	B72220Q0301K101	300	385	15000	235	1,20
Q20K320	B72220Q0321K101	320	420	15000	255	1,20



**Characteristics ( $T_A = 25\text{ °C}$ )**

Type (untaped) SIOV-	$V_V$ (1 mA) V	$\Delta V_V$ (1 mA) %	Max. clamping voltage		$C_{typ}$ (1 kHz) pF	Derating curve Page	V/I char- acteristic Page
			$v$ V	$i$ A			
Q14K130	205	$\pm 10$	340	65	980	258	279
Q14K140	220	$\pm 10$	360	65	900	258	279
Q14K150	240	$\pm 10$	395	65	830	258	279
Q14K175	270	$\pm 10$	455	65	750	258	279
Q14K210	330	$\pm 10$	550	65	600	258	279
Q14K230	360	$\pm 10$	595	65	550	258	279
Q14K250	390	$\pm 10$	650	65	500	258	279
Q14K275	430	$\pm 10$	710	65	470	258	279
Q14K300	470	$\pm 10$	775	65	430	258	279
Q14K320	510	$\pm 10$	840	65	390	258	279
Q20K130	205	$\pm 10$	340	130	1950	258	279
Q20K140	220	$\pm 10$	360	130	1800	258	279
Q20K150	240	$\pm 10$	395	130	1650	258	279
Q20K175	270	$\pm 10$	455	130	1500	258	279
Q20K210	330	$\pm 10$	550	130	1200	258	279
Q20K230	360	$\pm 10$	595	130	1100	258	279
Q20K250	390	$\pm 10$	650	130	1000	258	279
Q20K275	430	$\pm 10$	710	130	930	258	279
Q20K300	470	$\pm 10$	775	130	850	258	279
Q20K320	510	$\pm 10$	840	130	780	258	279

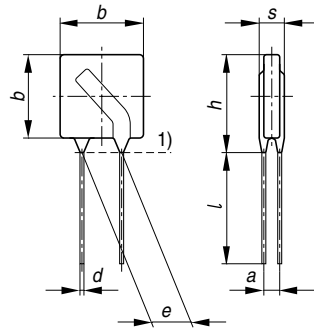

## Leaded Varistors

### EnergetiQ Series



1) Seating plane in accordance with IEC 60717

VAR0393-T

### Dimensions

Type	$e \pm 1$ mm	$a \pm 1$ mm	$b_{\max}$ mm	$s_{\max}$ mm	$h_{\max}$ mm	$l_{\min}$ mm	$d \pm 0,05$ mm
SIOV-Q14K130	10,0	1,9	16,5	5,0	19,5	30,0	1,0
SIOV-Q14K140	10,0	2,0	16,5	5,1	19,5	30,0	1,0
SIOV-Q14K150	10,0	2,1	16,5	5,2	19,5	30,0	1,0
SIOV-Q14K175	10,0	2,2	16,5	5,3	19,5	30,0	1,0
SIOV-Q14K210	10,0	2,2	16,5	5,4	19,5	30,0	1,0
SIOV-Q14K230	10,0	2,3	16,5	5,5	19,5	30,0	1,0
SIOV-Q14K250	10,0	2,4	16,5	5,7	19,5	30,0	1,0
SIOV-Q14K275	10,0	2,6	16,5	5,8	19,5	30,0	1,0
SIOV-Q14K300	10,0	2,8	16,5	6,1	19,5	30,0	1,0
SIOV-Q14K320	10,0	2,9	16,5	6,3	19,5	30,0	1,0
SIOV-Q20K130	10,0	1,9	22,5	5,0	27,0	30,0	1,0
SIOV-Q20K140	10,0	2,0	22,5	5,1	27,0	30,0	1,0
SIOV-Q20K150	10,0	2,1	22,5	5,2	27,0	30,0	1,0
SIOV-Q20K175	10,0	2,2	22,5	5,3	27,0	30,0	1,0
SIOV-Q20K210	10,0	2,2	22,5	5,4	27,0	30,0	1,0
SIOV-Q20K230	10,0	2,3	22,5	5,5	27,0	30,0	1,0
SIOV-Q20K250	10,0	2,4	22,5	5,7	27,0	30,0	1,0
SIOV-Q20K275	10,0	2,6	22,5	5,8	27,0	30,0	1,0
SIOV-Q20K300	10,0	2,8	22,5	6,1	27,0	30,0	1,0
SIOV-Q20K320	10,0	2,9	22,5	6,3	27,0	30,0	1,0

**Herausgegeben von EPCOS AG**

**Unternehmenskommunikation, Postfach 80 17 09, 81617 München, DEUTSCHLAND**

**☎ ++49 89 636 09, FAX (0 89) 636-2 26 89**

© EPCOS AG 2002. Vervielfältigung, Veröffentlichung, Verbreitung und Verwertung dieser Broschüre und ihres Inhalts ohne ausdrückliche Genehmigung der EPCOS AG nicht gestattet.

Bestellungen unterliegen den vom ZVEI empfohlenen Allgemeinen Lieferbedingungen für Erzeugnisse und Leistungen der Elektroindustrie, soweit nichts anderes vereinbart wird.

Diese Broschüre ersetzt die vorige Ausgabe.

Fragen über Technik, Preise und Liefermöglichkeiten richten Sie bitte an den Ihnen nächstgelegenen Vertrieb der EPCOS AG oder an unsere Vertriebsgesellschaften im Ausland. Bauelemente können aufgrund technischer Erfordernisse Gefahrstoffe enthalten. Auskünfte darüber bitten wir unter Angabe des betreffenden Typs ebenfalls über die zuständige Vertriebsgesellschaft einzuholen.

**Published by EPCOS AG**

**Corporate Communications, P.O. Box 80 17 09, 81617 Munich, GERMANY**

**☎ ++49 89 636 09, FAX (0 89) 636-2 26 89**

© EPCOS AG 2002. Reproduction, publication and dissemination of this brochure and the information contained therein without EPCOS' prior express consent is prohibited.

Purchase orders are subject to the General Conditions for the Supply of Products and Services of the Electrical and Electronics Industry recommended by the ZVEI (German Electrical and Electronic Manufacturers' Association), unless otherwise agreed.

This brochure replaces the previous edition.

For questions on technology, prices and delivery please contact the Sales Offices of EPCOS AG or the international Representatives.

Due to technical requirements components may contain dangerous substances. For information on the type in question please also contact one of our Sales Offices.