

SE Quadrature Dual Shaft Encoder

The SE Quadrature Dual-Shaft Encoders combine the most routinely used features in one standard device, and are available with a selection of five different resolutions (pulses/revolution).

The cube-style unit uses an infrared light source and precision mechanical components to provide exact, repeatable counts.

Mounting the encoder is quick and easy using the pre-drilled holes in the base flange, or the housing mounting holes located at each shaft output.

This encoder can be used as a direct replacement for other brand encoders, with no blind holes to drill. The double-ended, flatkeyed shaft permits a choice of mounting positions. Chrome steel bearings provide 20% longer life than stainless steel bearings.

To aid in troubleshooting, LEDs are located directly on the body to instantly verify correct output operation. Quadrature output is standard and can be externally scaled to provide any engineering unit (RPM, angular position, feet/min., etc.). Gold-plated connectors ensure maximum signal transfer. Very low power consumption; typical current draw, 35mA @ 15DCV.



Specifications	
DISPLAY	
System OK LED, operation/verification on trouble shooting aid	
INPUTS	
12 - 28 DCV - 35mA @ 15 DCV typical	
High Noise immunity	
Short circuit protection	
Reverse polarity protection	
OUTPUT	
Square wave with 50% duty cycle 0 - 10,000 pulse/sec.	
MECHANICAL	
Housing -- rugged anodized aluminum	
Shaft Rotation -- either direction	
Shaft Speed -- 6,000 RPM max.	
Shaft -- stainless steel	
Bearings -- heavy duty chrome steel	
Load -- 30 lbs. radial; 10 lbs. axial	
ENVIRONMENTAL	
32°F to 149°F (0-65°C)	

Ordering Information	
Catalog No.	Pulses Per Revolution
SE-060	60
SE-100	100
SE-120	120
SE-360	360
SE-600	600

The encoder and its accessories can be used with Simpson counters S660, S661, S662 and S663.

Accessories -



Chariot

The Chariot is used to mount most cube-style quadrature encoders and measuring wheels. Made of anodized aluminum, the chariot includes mounting hardware and selectable pivotal points. Wheels, tires, and flexible shaft couplings are sold separately.

Catalog No. 46012

Flexible Shaft Couplings

The one-piece flexible coupling connects the shaft of a cube-style encoder to an ancillary equipment shaft without worry of misalignment of rotary frequency. The coupling ensures minimum windup, minimum rotary oscillation, and no hysteresis.

Coupling: For connecting an encoder to a 3/8" shaft. **Catalog No. 46002**

Coupling package: For connecting an encoder to 1/4" or 5/16" diameter shaft.
Package includes: One flexible coupling (1/2" I.D.) and three reducing inserts (1/4", 5/16", 3/8").
Catalog No. 46003



Tire Durometer

A Simpson 12" circumference anodized aluminum measuring wheel is the right choice to complete the setup of a length measurement system.

Whether the application requires one or two, Simpson's measuring wheels will perform accurately and reliably throughout the measuring process.

Also included on the measuring wheel is a printed alignment scale which assists in the installation and measurement of the length measurement system.

Simpson offers four replaceable durometer tires that consist of a black tire that has a longer life span and three non marking tires. The three non marking tires are for delicate materials such as plastics, textiles, wood, metal and paper to prevent tearing, damage or marking of delicate materials.

80A, black tire; longer service life for plastics, metals. **Catalog No. 46004**

83A, non-marking tire for textiles, medium textures. **Catalog No. 46005**

92A, non-marking tire for plastics, metals, coarse wood. **Catalog No. 46006**

70A, non-marking tire for soft textiles. **Catalog No. 46007**

5 Feet Cable Assembly **Catalog No. 46013**

10 Feet Cable Assembly **Catalog No. 46014**

15 Feet Cable Assembly **Catalog No. 46015**

SE Quadrature Dual Shaft Encoder

Dimensions - S660, S661, S662, S663

Mounting Requirements -

The S660 series 1/8 DIN counters require a panel cutout of 1.77" (45mm) high by 3.62" (92mm) wide.

To install the counter into a panel cutout, remove the clips from the side of the meter.

Slide the meter through your panel cutout, then slide the mounting clips back on the meter.

Press evenly to ensure a proper fit.

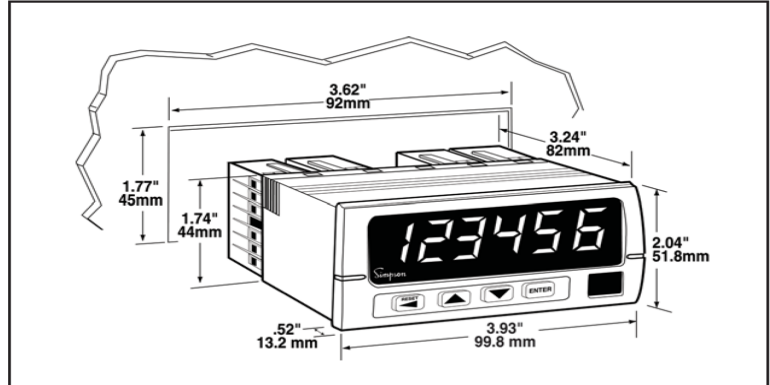

WIRING INFORMATION

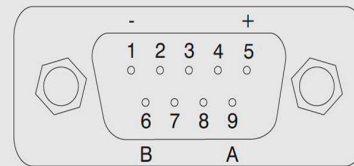
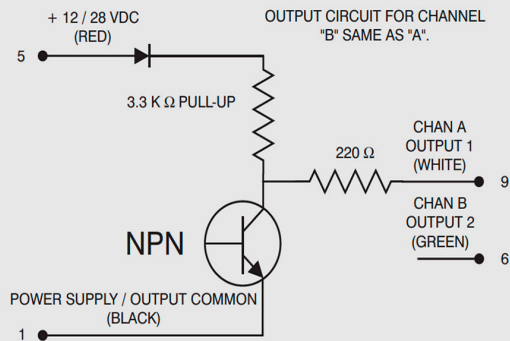

VIEW OF THE CONNECTOR ON THE ENCODER.

Mechanical Information

