

PLAN POLACZEN DLA A I B
WIRING DIAGRAM FOR A AND B

| Pin | Kolor przew. | Wire color |
|-----|--------------------|------------|
| 1 | ZIELONO/BIALY | GN/WH |
| 2 | ZIELONY | GN |
| 3 | POMARANCZOWO/BIALY | OG/WH |
| 4 | NIEBIESKI | BU |
| 5 | NIEBIESKI/BIALY | BU/WH |
| 6 | POMARANCZOWY | OG |
| 7 | BRAZOWO/BIALY | BN/WH |
| 8 | BRAZOWY | BN |
| GND | EKRAN | SHIELD |

TABELA 1
TABLE 1

| MOLEX PN | ENGINEERING PN | L[mm] |
|------------|----------------|-------|
| 1300500018 | ENC2225M020 | 2000 |
| 1300509012 | ENC2225M010 | 1000 |
| 1300508048 | ENC2225M030 | 3000 |
| 1300500523 | ENC2225M100 | 10000 |

WIDOK OD STRONY CZOLA
FRONT SIDE VIEW

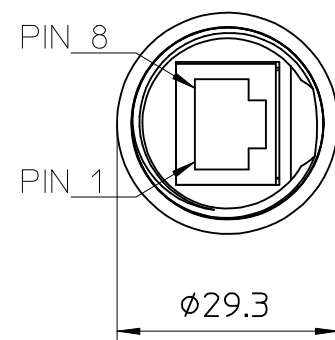

A

B

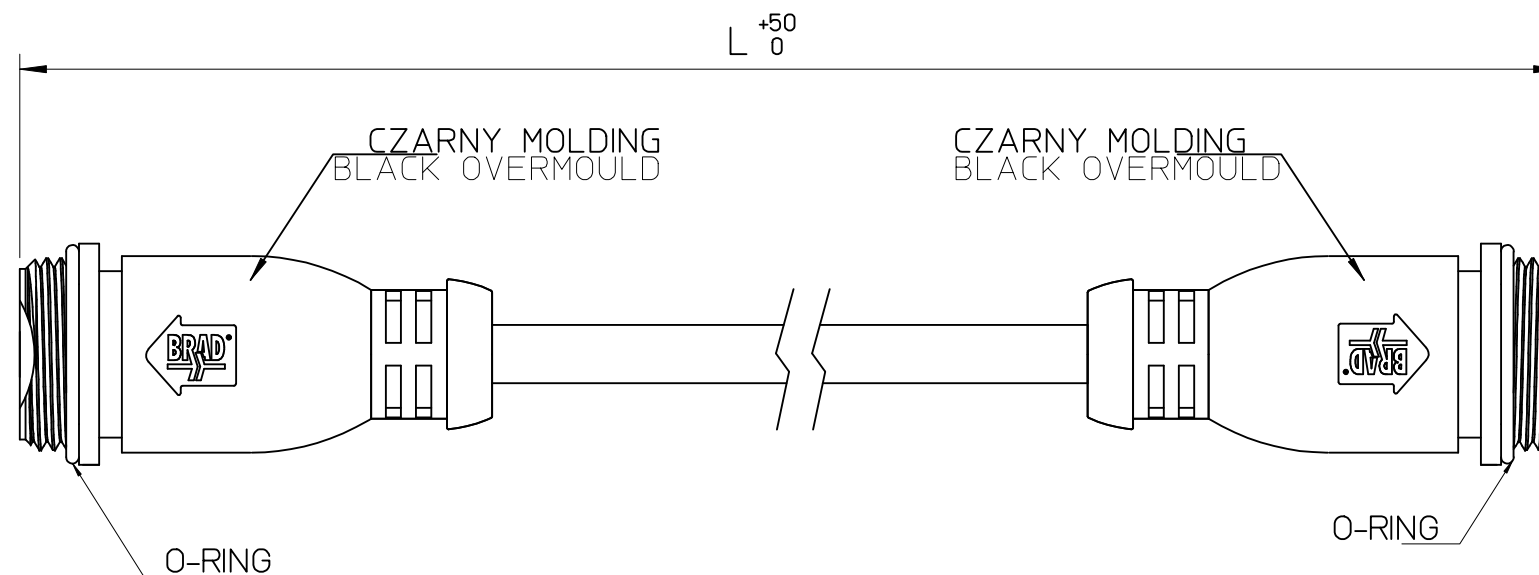

WIDOK OD STRONY CZOLA
FRONT SIDE VIEW

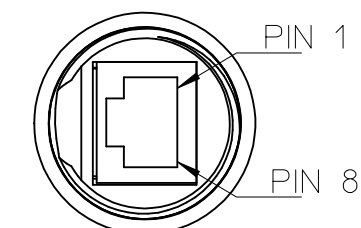

UWAGI:

1. PRODUKOWAC ZGODNIE Z INSTRUKCJA VVK1_392_Zal_18.

NOTES:

1. USE INSTRUCTION No VVK1_392_Zal_18.

| | |
|------------------------------|-------------|
| PIN 1 AND 8 ADDED | DESCRIPTION |
| EC NO: IPG2015-0261 | |
| DRWN: DSTACHOWIAK 2015/02/10 | |
| CHKD: FGAIK 2015/02/23 | |
| APPR: MIWASIECZKO 2015/02/23 | |
| A1 | REV |

| QUALITY SYMBOLS | DESCRIPTION |
|-----------------|-------------|
| ▽=0 | |
| ∇=0 | |

| GENERAL TOLERANCES (UNLESS SPECIFIED) | | |
|--|-------|-------|
| | mm | INCH |
| 4 PLACES | ± --- | ± --- |
| 3 PLACES | ± --- | ± --- |
| 2 PLACES | ± --- | ± --- |
| 1 PLACE | ± --- | ± --- |
| 0 PLACE | ± --- | ± --- |
| ANGULAR ± --- ° | | |
| DRAFT WHERE APPLICABLE MUST REMAIN WITHIN DIMENSIONS | | |

| DIMENSION STYLE | | SCALE | DESIGN UNITS | THIRD ANGLE PROJECTION |
|---|------------|--------------------------|--------------|------------------------|
| MM ONLY | | --- | METRIC | ☉ |
| DRAWN BY | DATE | TITLE | | |
| MWOLSZCZAK | 2008/09/09 | EN 568A FE/FE-RJ45MLD-XM | | |
| CHECKED BY | DATE | | | |
| DWARWAS | 2008/09/09 | | | |
| APPROVED BY | | DOCUMENT NO. | | |
| MATERIAL NO. | | SHEET NO. | | |
| SEE TABLE 1 | | E-130050-031 | | |
| SIZE A3 | | 1 OF 1 | | |
| THIS DRAWING CONTAINS INFORMATION THAT IS PROPRIETARY TO MOLEX INCORPORATED AND SHOULD NOT BE USED WITHOUT WRITTEN PERMISSION | | | | |