



Main

Range of product	OsiSense XC
Series name	Special format
Product or component type	Limit switch
Product specific application	Materials handling
Device short name	XC1AC
Sensor design	-
Body type	Fixed
Head type	Plunger head
Material	Metal
Fixing mode	By the body
Movement of operating head	Linear
Type of operator	Spring return roller lever metal -
Switch actuation	By 30° cam
Type of approach	Lateral approach 2 directions
Electrical connection	Screw-clamp terminals, 1 x 0.5...1 x 2.5 mm ²
Cable entry	3 entries tapped for Pg 13.5 cable gland, cable outer diameter: 9...12 mm
Number of poles	1
Contacts type and composition	1 C/O
Contacts operation	Slow-break
Number of steps	1
Positive opening	Without
Minimum force for tripping	23 N

Complementary

Contacts insulation form	Za
Maximum actuation speed	0.5 m/s
[Ithe] conventional enclosed thermal current	10 A
[Ui] rated insulation voltage	500 V AC IEC 60947-5-1 500 V AC NF C 20-040 600 V DC IEC 60947-5-1 600 V DC NF C 20-040 600 V AC CSA C22.2 No 14 600 V DC CSA C22.2 No 14
Resistance across terminals	<= 8 mOhm
Short circuit protection	10 A cartridge fuse gG

The information provided in this documentation contains general descriptions and/or technical characteristics of the performance of the products contained herein. This documentation is not intended as a substitute for and is not to be used for determining suitability or reliability of these products for specific user applications. It is the duty of any such user or integrator to perform the appropriate and complete risk analysis, evaluation and testing of the products with respect to the relevant specific application or use thereof. Neither Schneider Electric Industries SAS nor any of its affiliates or subsidiaries shall be responsible or liable for misuse of the information contained herein.

Electrical durability	1000000 cycles AC-15, 110 V 900 VA, <= 60 cyc/mn, load factor: 0.5 conforming to IEC 60947-5-1 appendix C 50/60 Hz, inductive load type 1000000 cycles AC-15, 230 V 1900 VA, <= 60 cyc/mn, load factor: 0.5 conforming to IEC 60947-5-1 appendix C 50/60 Hz, inductive load type 1000000 cycles AC-15, 48 V 450 VA, <= 60 cyc/mn, load factor: 0.5 conforming to IEC 60947-5-1 appendix C 50/60 Hz, inductive load type 1000000 cycles DC-13, 110 V 100 W, <= 60 cyc/mn, load factor: 0.5 conforming to IEC 60947-5-1 appendix C inductive load type 1000000 cycles DC-13, 230 V 95 W, <= 60 cyc/mn, load factor: 0.5 conforming to IEC 60947-5-1 appendix C inductive load type 1000000 cycles DC-13, 48 V 100 W, <= 60 cyc/mn, load factor: 0.5 conforming to IEC 60947-5-1 appendix C inductive load type 3000000 cycles AC-15, 110 V 350 VA, <= 60 cyc/mn, load factor: 0.5 conforming to IEC 60947-5-1 appendix C 50/60 Hz, inductive load type 3000000 cycles AC-15, 230 V 430 VA, <= 60 cyc/mn, load factor: 0.5 conforming to IEC 60947-5-1 appendix C 50/60 Hz, inductive load type 3000000 cycles AC-15, 48 V 170 VA, <= 60 cyc/mn, load factor: 0.5 conforming to IEC 60947-5-1 appendix C 50/60 Hz, inductive load type 3000000 cycles DC-13, 110 V 40 W, <= 60 cyc/mn, load factor: 0.5 conforming to IEC 60947-5-1 appendix C inductive load type 3000000 cycles DC-13, 230 V 33 W, <= 60 cyc/mn, load factor: 0.5 conforming to IEC 60947-5-1 appendix C inductive load type 3000000 cycles DC-13, 48 V 35 W, <= 60 cyc/mn, load factor: 0.5 conforming to IEC 60947-5-1 appendix C inductive load type
Mechanical durability	10000000 cycles
Width	77 mm
Height	130 mm
Depth	44 mm
Product weight	0.53 kg
Terminals description ISO n°1	(11-12)NC (13-14)NO

Environment

Shock resistance	95 gn 11 ms IEC 60068-2-27
Vibration resistance	9 gn 10...500 Hz IEC 60068-2-6
IP degree of protection	IP65 IEC 60529 IP65 NF C 20-010
Class of protection against electric shock	Class I conforming to IEC 61140 Class I conforming to NF C 20-030
Ambient air temperature for operation	-25...70 °C
Ambient air temperature for storage	-40...70 °C
Protective treatment	TC
Operating position	Any position
Product certifications	CSA
Standards	EN 60947-5-1 IEC 60337-1 IEC 60947-5-1 VDE 0660-200 CSA C22.2 No 14

Offer Sustainability

Sustainable offer status	Not Green Premium product
RoHS (date code: YYWW)	Will not be Compliant
REACH	Reference not containing SVHC above the threshold
Product end of life instructions	Need no specific recycling operations

Dimensions

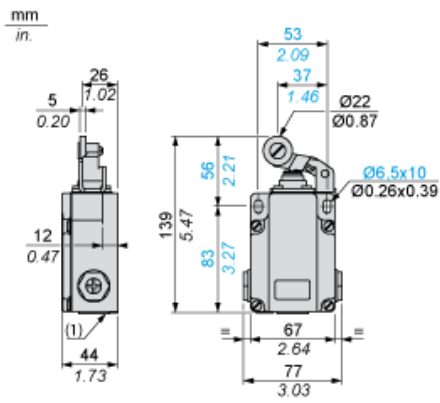

(1) 3 tapped entries for Pg 13.5 cable gland

Adaptator Dimensions for ISO M20 x 1.5

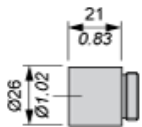

Wiring Diagram

Single-pole CO Slow Break

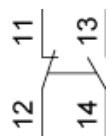

Characteristics of Actuation

Switch Actuation by 30° Cam

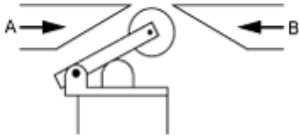

Functionnal Diagram

