

XEP4E1W7

miniature limit switch - flat plunger - 2.8 mm
cable clip tags



Main

Range of product	OsiSense XC
Series name	Special format
Product or component type	Microswitch
Device short name	XEP4
Detector design	Subminiature, DIN 41635 B format, sealed
Head type	Plunger head
Movement of operating head	Linear
Type of operator	Plunger
Switch actuation	On end
Type of approach	Vertical approach
Electrical connection	2.8 mm cable clip tags
Contacts type and composition	1 C/O standard
Contacts operation	Snap action
Contacts material	AgCdO

Complementary

Body material	Polyester
Tags material	Tinned brass
Maximum force for tripping	2.5 N lever fixing position in A 2.5 N lever fixing position in B
Minimum release force	0.8 N lever fixing position in A 0.8 N lever fixing position in B
Maximum permanent end of travel force	10 N lever fixing position in A 10 N lever fixing position in B
Tripping point	8.4 mm lever fixing position in A 8.4 mm lever fixing position in B
Maximum differential travel	0.13 mm lever fixing position in A 0.13 mm lever fixing position in B
Minimum over travel	0.6 mm lever fixing position in A 0.6 mm lever fixing position in B
Inter contact distance	0.4 mm
Contact code designation	B300; AC-15(Ue = 240 V, Ie = 1.5 A) conforming to EN/IEC 60947-5-1 appendix A R300; DC-13(Ue = 250 V, Ie = 0.1 A) conforming to EN/IEC 60947-5-1 appendix A
[Ith] conventional free air thermal current	7.5 A at 250 V 50/60 Hz
Mechanical durability	2000000 cycles
Width	6 mm
Height	10 mm
Depth	20 mm
Product weight	2.4 g
Terminals description ISO n°1	(1-2-4)OC

The information provided in this documentation contains general descriptions and/or technical characteristics of the performance of the products contained herein. This documentation is not intended as a substitute for and is not to be used for determining suitability or reliability of these products for specific user applications. It is the duty of any such user or integrator to perform the appropriate and complete risk analysis, evaluation and testing of the products with respect to the relevant specific application or use thereof. Neither Schneider Electric Industries SAS nor any of its affiliates or subsidiaries shall be responsible or liable for misuse of the information contained herein.

Environment

IP degree of protection	IP67
Ambient air temperature for operation	-40...125 °C
Marking	CE
Standards	CURus EN 60947-5-1 EN 61058 IEC 60947-5-1 UL 1054

Offer Sustainability

Sustainable offer status	Green Premium product
RoHS (date code: YYWW)	Compliant - since 0544 - Schneider Electric declaration of conformity
REACH	Reference not containing SVHC above the threshold
Product end of life instructions	Need no specific recycling operations

Dimensions

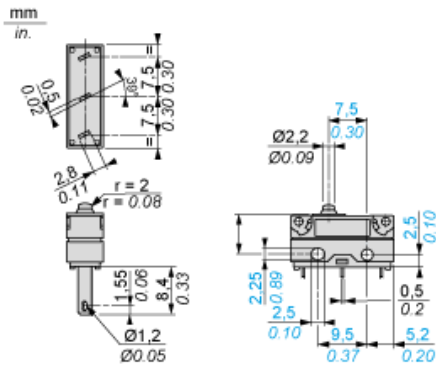

Wiring Diagram

Single-pole CO Snap Action

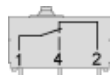

- 1 : Black
- 2 : Grey
- 4 : Blue

Operating Curves

250 V AC : Resistive circuit

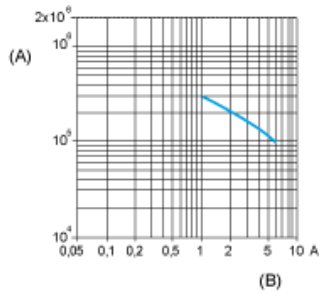

- (A) Number of cycles
- (B) Current