

XZCE13M125M

adaptor, metal - tapped hole Pg 13.5 - for male connector, M12, 5-wire

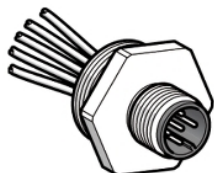

Main

Accessory / separate part designation	5-wire connector adaptor
Accessory / separate part category	Cabling accessories
Accessory / separate part type	Connector adaptor
Cable composition	4 x 0.34 mm ² + 1 x 0.5 mm ²
Thread type	Pg 13.5
[In] rated current	4 A

Complementary

Cable length	100 mm
Total number of wires	5
Electrical connection	1 male connector M12 5 straight
Cable connector fixing	Screw-on
Body material	Metal
Insulation resistance	> 1000000000 Ohm
Resistance across terminals	<= 5000 mOhm
[Ue] rated operational voltage	250 V AC 300 V DC
Product weight	0.025 kg

Environment

IP degree of protection	IP67
Ambient air temperature for operation	-25...80 °C

Offer Sustainability

Sustainable offer status	Not Green Premium product
RoHS (date code: YYWW)	Compliant - since 0545 - Schneider Electric declaration of conformity

The information provided in this documentation contains general descriptions and/or technical characteristics of the performance of the products contained herein. This documentation is not intended as a substitute for and is not to be used for determining suitability or reliability of these products for specific user applications. It is the duty of any such user or integrator to perform the appropriate and complete risk analysis, evaluation and testing of the products with respect to the relevant specific application or use thereof. Neither Schneider Electric Industries SAS nor any of its affiliates or subsidiaries shall be responsible or liable for misuse of the information contained herein.

Dimensions

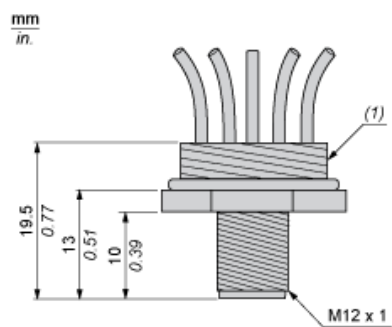

(1) Pg 13.5 cable gland

Connections and Schemes

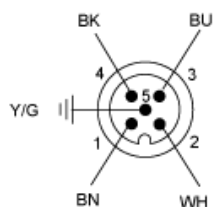

BN : Brown
BK : Black
BU : Blue
Y/G : Yellow / Green
WH : White