

规格承认书

SPECIFICATION FOR APPROVAL

CUSTOMER 客户: _____
CUSTOMER P.N. 客户料号: _____
MODEL NO. 产品型号: PSE-480050UK
DESIGN NO. 设计编号: _____
DATE 日期: 2017-11-15

CUSTOMER AUTHORIZED SIGNATURE / 客户承认签章		

Please return to us one copy of "SPECIFICATION FOR APPROVAL" with you
Approved signature./ /客户确认签字, 盖章后请回传一份承认书给我司.

深圳市星维科技有限公司

Shenzhen Starwell Technology Co.,Ltd



深圳市宝安区松岗街道燕川社区惠明盈工业园 12 栋 3 楼

3rd FL 12th Building huimingying industrial park yanchuan songgang street baoan District

Shenzhen ,China 518101

T EL: 86-755-29634321

FAX: 86-755-29634322

Http://www.starwell.cc

制作: Prepared By :	审核: Checked By :王在建	批准: Approved By
----------------------	------------------------	--------------------

索引 (Index)

1. 描述 (Description)	4
2. 电气规格 (Electrical Specification)	4
3. 保护功能 (Protection)	5
4. 可靠性 (Reliability)	5
5. 环境特性 (Environment)	6
6. 安全及 EMI 要求 (Safety and EMI Requirement)	7
7. 测试设备清单 (Test Equipment List)	8
8. 结构参数 (Mechanical Requirement)	8
9. 机械规格 (Mechanical Specifications)	9
10. 重量 (Weight)	10
11. 铭牌图 (Label Drawing)	10
12. 包装图 (Package Drawing)	11
13. 样品测试报告 (Samples test report)	12

1. 描述 (Description)

本规格书适应于 PSE-480050U K 型号的开关电源。
switching power whose model no. is PSE-480050UK

This specification apply to the

2. 电气规格 (Electrical Specification)

1. 2.1 输入 (INPUT)

输入电压范围 (Input voltage range)	90Vac - 264Vac
额定输入电压范围 (Rated voltage range)	100Vac - 240Vac
适用频率范围 (Input frequency range)	47Hz-63Hz
额定频率 (Rated input frequency)	50Hz/60Hz
输入电流 (Input current)	0.3A _{max.} at full load
浪涌电流【Inrush current(cold start)】	50A _{typ peak} , 220Vac Input

2.2 输出 (OUTPUT)

2.2.1 额定输出 (Rated Output)

输出电压 Output Voltage (Vdc)	输出电压范围 Output Volt Limit (Vdc)	纹波&噪声 Ripple & Noise (mV)	输出电流 Output Current (A)	功率 Output power (W)	过流保护 OCP (A)
48	45.6-50.6	240	0.5	24W	0.8A

注 (Notes): 在测试纹波时示波器带宽调至 20MHz, 示波器的测试端并联一粒 10uF 的电解电容和一粒 0.1uF 的瓷片电容。(Ripple Voltage is measured with oscilloscope with bandwidth 20MHz . A 10uF E-cap and 0.1uF ceramic-cap shall be connected to the connector in parallel.)

2.2.2 输出超调 (DC Output Overshoot At Turn On & Turn Off)

输出电压 Output Voltage (V)	输出超调电压比例 Proportion of the output voltage overshoot	
	开通 Turn on	关断 Turn off
48V	5%	5%

注 (Note): 在全部电流范围内进行测试 (All of dc output current from Min. to Max..)

2.2.3 负载特性,调整率 (Combined Load/Line Regulation)

电压 Voltage	最小负载 Min. Load	额定负载 Rated. Load	线性调整 Line Regulation	负载调整 Load Regulation
48Vdc	0A	0.5A	±5%	±5%

2.2.5 启动延迟时间 (Turn on delay time) :

当输入 115Vac 和输出最大负载时,最大启动时间为 3S.

3Second Max. at 115Vac input and output Max. load.

2.2.6 上升时间 (Rise time) :

当输入 115Vac 和输出最大负载时最大时间为 40ms.

40ms Max. at 115Vac input and output Max load.

2.2.7 保持时间 (Hold up time) :

当输入 115Vac 和输出最大负载时,最小保持时间为 5ms.

5ms Min. at 115Vac input and output Max. Load.

2.2.8 效率 (Efficiency COC Tier 2/DOE/ERP/MEPS Level VI) :

当 230Vac 输入时, 输出在 25%, 50%, 75%及满载情况下, 平均效率需达到 **86.2%** (开机 30 分钟后测试. 输出在 10%负载下效率 **>76.2%**)

Average efficiency reach 86.2% minimum at 25%,50%,75%&100% of full-loading and 230Vac input (After warm up 30 minutes). Efficiency of 10% of full load Limit>76.2%

空载输入功率 \leq **0.1W(DOE) / 0.075W(ERP) .**

No-load input power \leq **0.1W(DOE) / 0.075W(ERP) .**

3. 保护功能 (Protection)

3.1 短路电路保护 (Short circuit protection) :

该电源供给器在短路解除时能正常工作恢复.

The power supply will be auto recovered after short circuit faults remove.

3.2 过流保护 (Over current Protection) :

保护点限制: 120%~150%自动保护, 过流故障排除后, 电源将自动恢复正常工作.

OCP limits to 120%~150% auto start, The power supply will be auto recovered after over current faults remove.

4. 可靠性要求 (Reliability Requirements)

4.1. 老化 (Burn-in)

产品至少要在 40°C±5°C 的环境及 80%额定负载条件下煲机 2-4 小时

The power supply shall be burn-in for 2-4 Hours under normal input and 80% rated load at 40°C±5°C

4.2. 平均间隔故障时间估算 (MTBF Qualification)

平均间隔故障时间: 至少 50,000 小时, 25°C 环境及额定输入与满载条件下

The MTBF shall be at least 50,000hours at 25°C, Full load and nominal input condition

5. 环境要求 (Environment Requirement)

5.1 工作温度 (Operating Temperature) :

0°C-40°C, 满载, 正常工作, 0°C to 40°C, Full load, Normal operation.

5.2 储藏温度 (Storage Temperature) :

-40°C to 85°C 【带外壳 (With package)】

5.3 工作湿度 (Relative Humidity) :

5% (0°C) ~95% (40°C) , 72 小时, 满载, 正常工作.

5% (0°C)~95% (40°C) RH, 72Hrs, Full load, Normal operating.

5.4 储藏湿度 (Storage Humidity) :

10% (0°C) ~90% (40°C) , 72 小时, 满载, 正常工作.

10% (0°C)~90% (40°C) RH, 72Hrs, Full load, Normal operating.

5.4 振动 (Vibration) :

5.4.1. 测试标准: 国际电工电子委员会

Operating: IEC 721-3-3 3M3

5~9Hz, A=1.5mm

9~200Hz, 加速度 Acceleration 5m / S2

5.4.2. 运输 (Transportation) :

IEC 721-3-2 2M2

5-9Hz, A=3.5mm

9~200Hz, 加速度 Acceleration=5m / S2

200~500Hz, 加速度 Acceleration=15m / S2

5.4.3. 轴向振动 (Axes, 10 cycles per axis):

在测试过程中不能出现永久性的损坏.

No permanent damage may occur during testing.

在电源开启和关闭后, 样机能够恢复到最初条件.

The product can restore to its original situation after power off / on.

5.5 跌落试验 (Dropping Packed) :

一个角, 三个棱, 六个面.

1 corner, 3 edges, and 6 surfaces

高度 76cm

Height: 76cm.

6. 安全及 EMI 要求 (Safety and EMI Requirement) :

6.1 安全:符合标准 (Safety: accord with):

certificate	国家/Country	standards	
<input type="checkbox"/> UL/CUL	美国/USA	UL60065	
<input checked="" type="checkbox"/> UL/CUL	美国/USA	UL60950	
<input type="checkbox"/> TUV/GS	欧洲/Europe	EN60065	
<input type="checkbox"/> TUV/GS	欧洲/Europe	EN60950	
<input checked="" type="checkbox"/> FCC	美国/USA	Class B	
<input type="checkbox"/> CE	欧洲/Europe	EN60065	
<input checked="" type="checkbox"/> CE	欧洲/Europe	EN60950	
<input type="checkbox"/> MEPS	澳洲/Australia	AS/NZS 4665	
<input checked="" type="checkbox"/> SAA	澳洲/Australia	AS/NZS 60950	
<input checked="" type="checkbox"/> SAA	澳洲/Australia	AS/NZS 60065	
<input type="checkbox"/> CCC	中国/China	GB8898	
<input type="checkbox"/> CCC	中国/China	GB4943	
<input checked="" type="checkbox"/> PSE	日本/Japan	J60950 (H22)	
<input type="checkbox"/> CB	欧洲/Europe	IEC60065	
<input checked="" type="checkbox"/> CB	欧洲/Europe	IEC60950	
<input checked="" type="checkbox"/> C-TICK	澳洲/Australia	AS/NZS CISPR13:2004	
<input type="checkbox"/> EK/KC	韩国/Korea	K60065	
<input type="checkbox"/> EK/KC	韩国/Korea	K60950	

6.2 EMI 标准 (EMI STANDARD):

GB9254	GB17625.1	GB13837	FCC- Part15
EN 55032	EN55024	CISPR 22	EN 61000-4-4
EN 61000-3-2	EN 61000-3-3	EN 61000-4-2	EN 61000-4-3
EN 61000-4-5	EN 61000-4-6	EN 61000-4-8	EN 61000-4-11

6.3 绝缘强度 (Dielectric Strength Testing):

绝缘强度满足下表的要求, 100% 在线产品执行此项测试, 并每一项目至少保持1分钟 时间, 无故障。
 Hi-pot test shall be met the table 1 requirements, an item listing this test as a 100% production test must be performed and be maintained at that level for a minimum of 1 min without failure.

项目 (ITEM)	测试规格 (SPECIFICATION)	距 离 distance	结果 (REMARK)
输入—输 Primary to Secondary	3000Vac/4242Vdc /10mA/1 min	7.0mm	无飞狐 No arcing
输入—地 Primary to P.G			无击穿 No broken
输出--地 Secondary to P.G			

6.4. Leakage Current/漏电流

0.25mA max. at 240Vac / 50Hz input/在输入240Vac/50Hz 的条件下最大0.25mA

6.5. Insulation Resistance/绝缘阻抗

100M Ω _ min. @ primary to secondary add a 500Vdc test voltage
 在初级与次级间加500Vdc 进行测试, 最小100M Ω _

7. 测试设备清单 (Test Equipment List)

项目	设备名称	制造	型号
1	变频电源 (AC power source)	Chroma	6120
2	示波器 (Oscilloscope)	Tektronix	TDS1002B
3	电子负载仪 (Electronic load)	TET	T3515
4	万用表 (Multimeter)	FLUCK	87III
5	功率计 (Dynamometer)	Chroma	2100
6	温度表 (Thermograph)	LUTRON	TW-902C
7	插头引线弯折试验机 (Plug lead bend test machine)	联欣	LX-817
8	盐雾试验机 (Salt spraying tester)	联欣	LX-8827B
9	震动台 (Vibration table)	精技实验	FZD-25
10	跌落测试台 (Drop test bed)	自制	
11	数显卡尺 (Digimatic caliper)	上海量具	0-150mm

8. 结构参数 (MECHANICAL REQUIREMENT) :

8.1 外壳 (Enclosure) :

外壳尺寸: L83.5*W47* H31.0mm;

The power supply size: L83.5*W47* H31.0mm;

8.2 输入线 (Input Connector) :

2 Pin 插脚

Two pin input plug.

8.3 产品外观图片 (Photograph of the product & packing method):

AU plug and Body should be packaged in plastic bubble bag

Bubble bag color: Clear color(transparent color).



9. 机械规格 (MECHANICAL SPECIFICATIONS)

Plastic material: ABS+PC, Color: Black. L83.5*W47* H31.0mm;

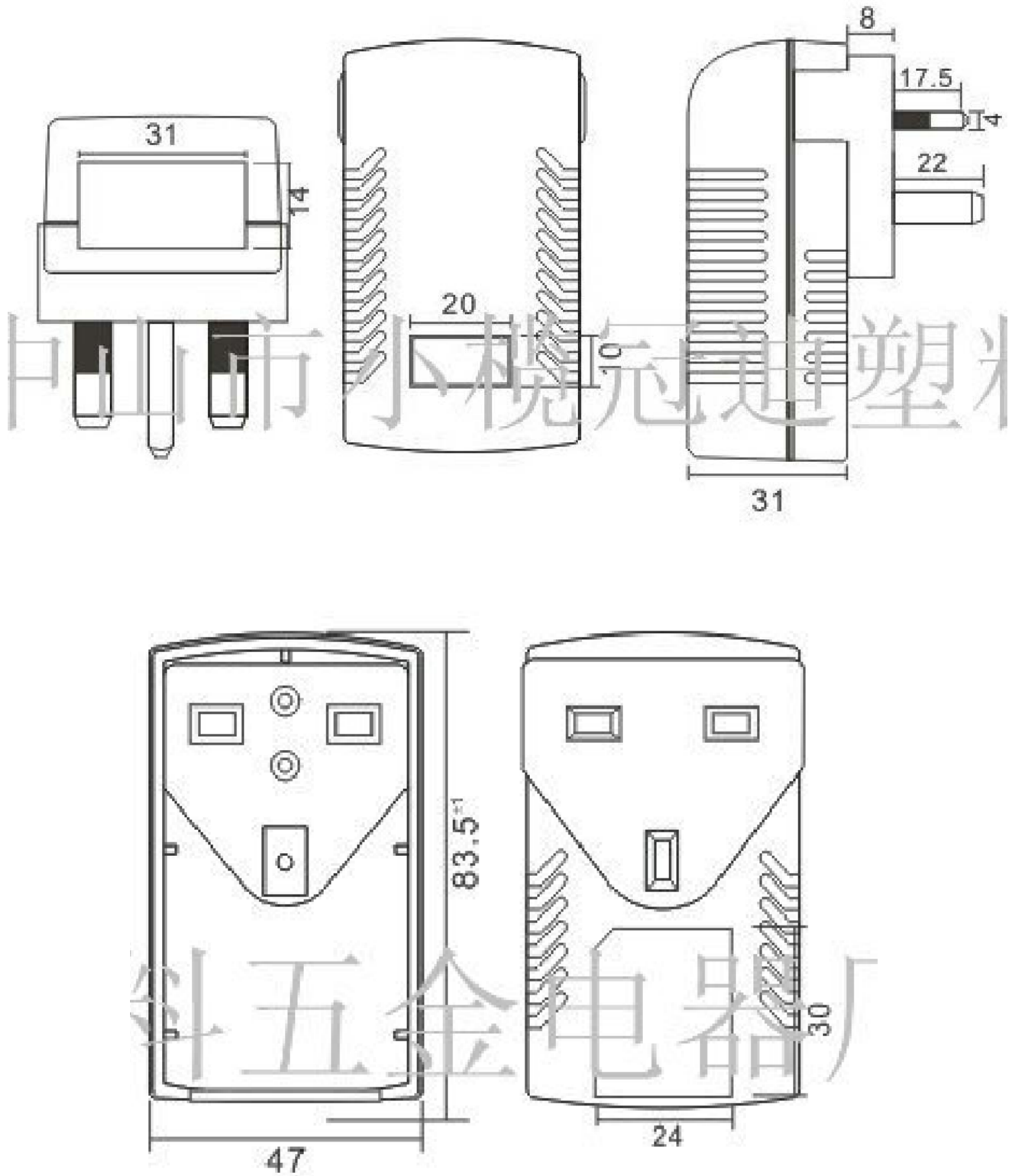

9.3 DC 线尺寸图 (DC Output Cord Drawing):

NA.

9.3 极性 (Polarity)

9.3.1. 极性 (Polarity):

8PIN RJ45 connector pin 4 & pin 5: V+ / pin 7 & pin 8: V-

10. 重量 (Weight)

电源的重量大约为 120 g. The weight of the power supply shall be about 120 g.

11. 客户需求/Client Request:

NONE.

12. 铭牌图 (Label Drawing)

黑底白字 (200#复合纸) 尺寸 24.0mmX30.0mm

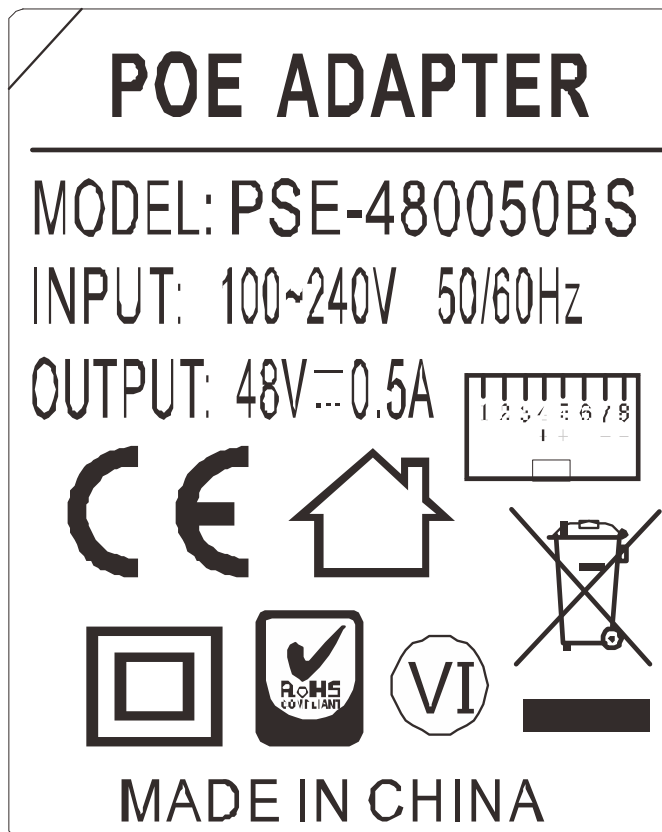

13. 小白盒 (White box)

尺寸(Dimension):200*65*60mm

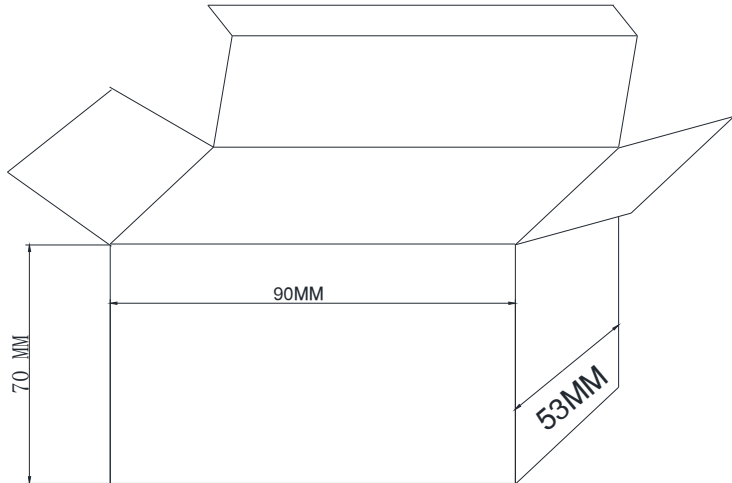
	1	2	3	4	5	6	7	8	9	10	11	12		
	REVISION					物料编码: PWB0003								
A	ISSUE	ZONE	DESCRIPTION	DATE	REVISER									
B	小白盒:												B	
C													C	
D													D	
E													E	
F													F	
G													G	
H	SMALL WHITE BOX ASS'Y MATERIAL: 250g面纸+C9坑纸 OUTSIDE BOX SIZE:90*53*70mm(L*W*H)												H	
I	STARWELL TECH CO.,LTD						DESIGN	CHECKED	APPROVED	UNIT	mm			I
	MODEL NO.		PART NO.		PART NAME		MATERIAL		DATE					
					PACKING BOX									
	1	2	3	4	5	6	7	8	9	10	11	12		

15 包装图 (Package Drawing)

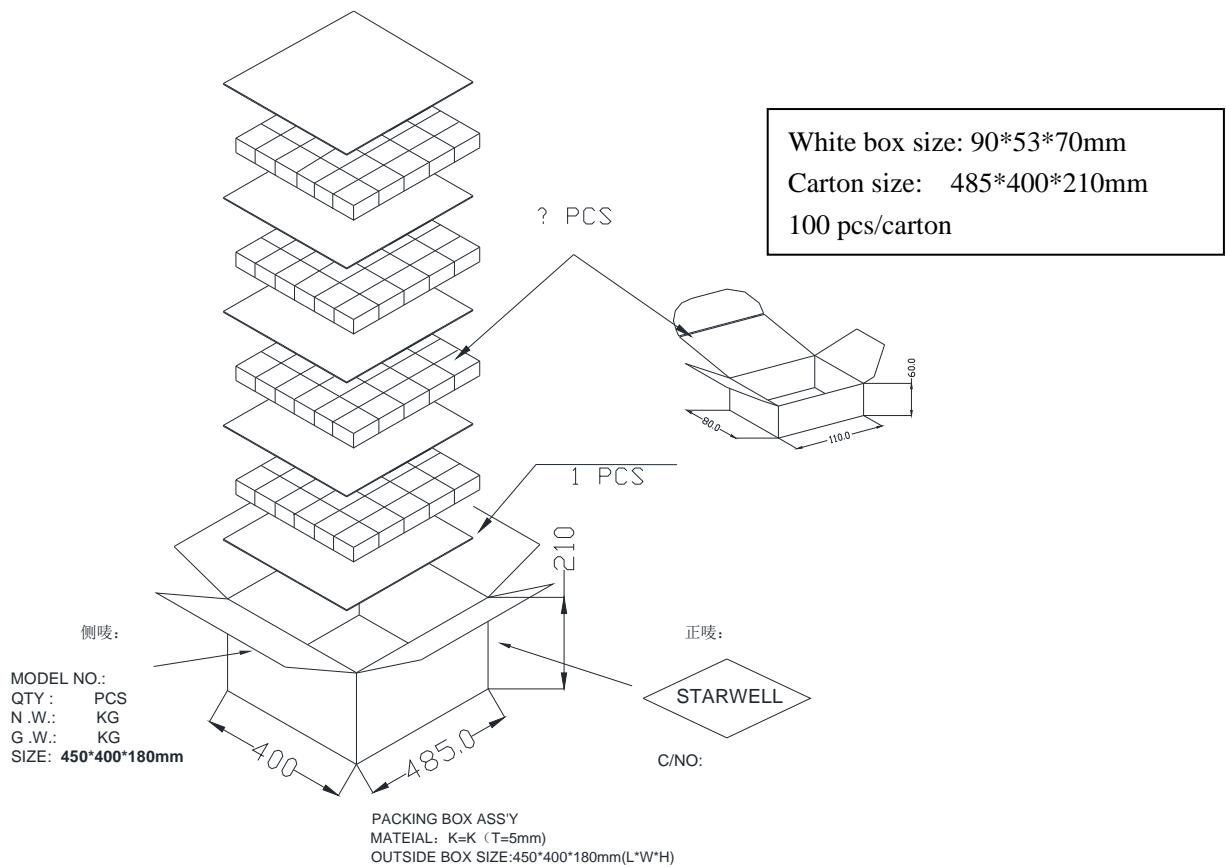

包装说明 (PACKING):

若客户未提出包装方式时, 均使用本公司之包装方式。

Our own packing style will be adopted if no special packing required .

a 内包装/inner package

小白盒/white box

b 外包装/ Outer package

纸箱/ paper-box.

尺寸: **485×400×210mm** ,

c 外包装箱标识/ Outer package notes include the information

客户、订单号、品名、数量、日期等信息

Customer Name, LOT Number, Model No., Date, and so on.

Sample Test Report / 样品测试报告

Customer / 客户	XW	Tester/测试员		Date: 2017-09-09				
Design No./ 设计编号:	Model No. / 机型: PSE-480050UK							
Test Items /测试项目	Test Condition / 测试条件	Sample quantity and test result /测试结果						PASS / FAIL
		#1	#2					
Unload output voltage / (CC mode)空载输出电压 (0.0A) 45.6Vdc~50.2Vdc	120Vac						PASS	
	230Vac						PASS	
Rated load output voltage / (CC mode)额定负载输出电压 (0.5A) 45.6Vdc~50.2Vdc	120Vac						PASS	
	230Vac						PASS	
Rate Load Cold Ripple(CC mode)冷态纹波 (0.5A) <120mV	120Vac						PASS	
	230Vac						PASS	
AC Over Voltage Protection AC 过压保护 300-350							----	

Short-circuit protection test / 短路保护测试	100Vac						PASS	
	220Vac						PASS	
Hi-pot / 介电强度	3000Vac/5 mA/3 秒						PASS	
Efficiency / 效率 > 87.5%	@220V						PASS	
450V Inrush 冲击	450V full load						----	