

MC21609AB6W-BNMLW-V2	2 x 16	9mm Character Height	LCD Module
Specification			
Version: 1		Date: 29/09/2016	
Revision			

Display Features			
Character Count	2 x 16		
Appearance	White on Blue		
Logic Voltage	5V		
Interface	Parallel		
Font Set	English / Japanese		
Display Mode	Transmissive		
Character Height	9.66mm		
LC Type	BSTN		
Module Size	122.00 x 44.00 x 13.50 mm		
Operating Temperature	-20°C ~ +70°C		
Construction	COB	Box Quantity	Weight / Display
LED Backlight	White	30 pcs	60 grams



RoHS
compliant

* - For full design functionality, please use this specification in conjunction with the SPLC780D specification. (Provided Separately)

Display Accessories	
Part Number	Description
MCCMDB-16SIL	LCD Interconnect board, can be driven from either a PC or a single Board computer with a USB output.
MCCBL1A16SLIP -16DILS-150	16 Way, Single in-line to Dual In-line connector Cable.
MCCBL1A16SLIP -16SILS-150	16 Way, Single in-line to Single In-line connector Cable.

Optional Variants		
Fonts	Appearances	Voltage
	Black on Yellow/Green Black on White	

Mechanical Specifications

Module Size	122.00 x 44.00 x 13.5 (With Backlight)				W x H x D mm
Viewing Area	99.00 x 24.00	W x H mm	Hole-to-Hole	115.00 x 37.00	W x H mm
Character Size	4.84 x 9.66	W x H mm	Character Pitch	1.16 x 0.68	W mm
Dot Size	0.92 x 1.10	W x H mm	Dot Pitch	0.06 x 0.06	W x H mm

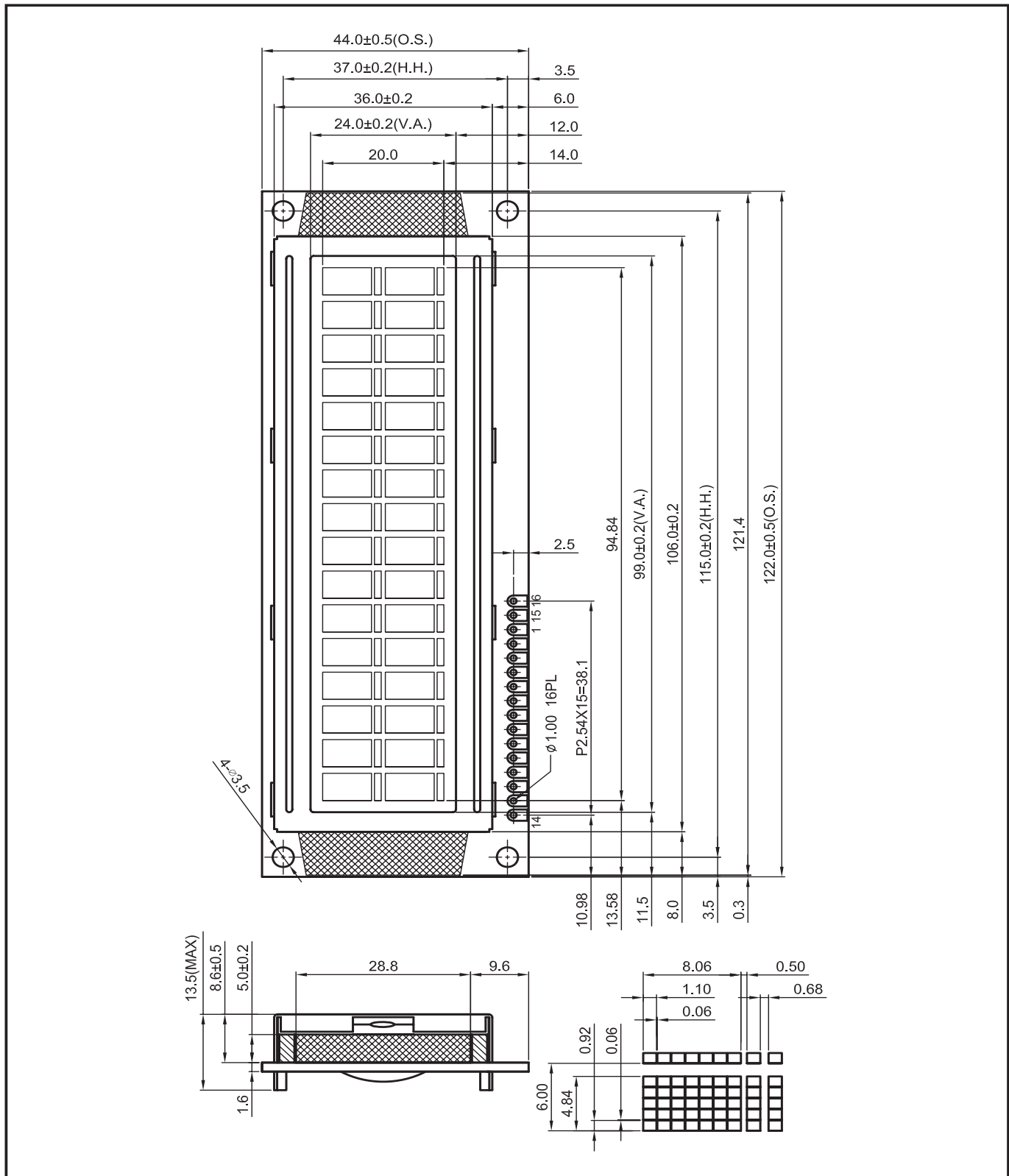

MC21609AB6W-BNMLW-V2	2 x 16	9mm Character Height	LCD Module
Specification			
Version: 1		Date: 29/09/2016	
Revision			

Pin Layout

PI	SYMBOL	DESCRIPTION	REMARKS
1	Vss	GND	
2	Vdd	Power supply for LCM	5.0V
3	V0	Contrast Adjust	
4	RS	Register Select Signal	
5	R/W	Data Read / Write	
6	E	Enable Signal	
7	DB0	Data bus line	
8	DB1	Data bus line	
9	DB2	Data bus line	
10	DB3	Data bus line	
11	DB4	Data bus line	
12	DB5	Data bus line	
13	DB6	Data bus line	
14	DB7	Data bus line	
15	LED-	Power supply for BKL	
16	LED+	Power supply for BKL	5.0V

Block Diagram

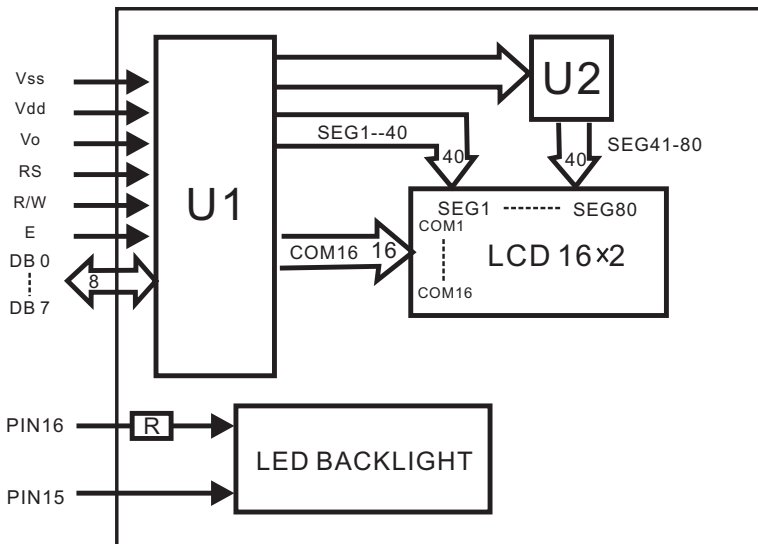

Power Supply Diagram

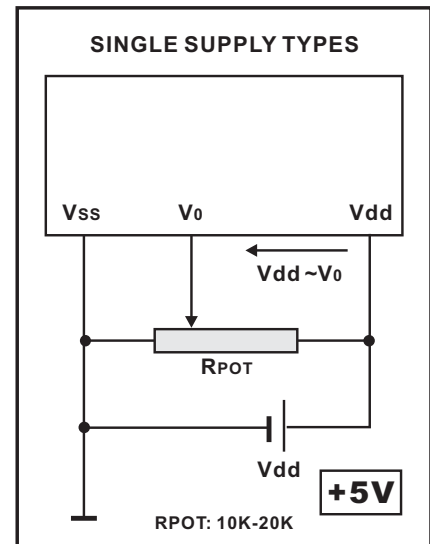

MC21609AB6W-BNMLW-V2	2 x 16	9mm Character Height	LCD Module
Specification			
Version: 1		Date: 29/09/2016	
Revision			

Font Map

Upper 4bit Lower 4bit	LLLL	LLLH	LLHL	LLHH	LHLL	LHLH	LHHL	LHHH	HLLL	HLLH	HLHL	HLHH	HHLL	HHLH	HHHL	HHHH
LLLL	CG RAM (1)															
LLLH	(2)															
LLHL	(3)															
LLHH	(4)															
LHLL	(5)															
LHLH	(6)															
LHHL	(7)															
LHHH	(8)															
HLLL	(1)															
HLLH	(2)															
HLHL	(3)															
HLHH	(4)															
HHLL	(5)															
HHLH	(6)															
HHHL	(7)															
HHHH	(8)															

MC21609AB6W-BNMLW-V2	2 x 16	9mm Character Height	LCD Module
Specification			
Version: 1		Date: 29/09/2016	
Revision			

Absolute Maximum Ratings						
Item	Symbol	Condition	Min	Typ	Max	Unit
Power Supply (LOGIC)	Vdd	25 °C	-0.3	---	7.0	V
Power Supply (LCD)	V0	25 °C	Vdd -13.5	---	Vdd +0.3	V
Input Voltage	Vin	25 °C	-0.3	---	Vdd +0.3	V
Operating Temperature	Vopr	---	-20	---	70	°C
Storage Temperature	Vstg	---	-30	---	80	°C

Electronic Characteristics						
Item	Symbol	Condition	Min	Typ	Max	Unit
Input Voltage	Vlcm = Vdd	---	---	5.0	---	V
Supply Current	Idd	Vdd=5V	---	1.5	---	mA
Driving Voltage for LCD Panel	Vlcd = (Vdd - V0)	-20 °C	4.30	---	4.55	V
		0 °C	4.20	---	4.6€	
		25 °C	4.10	4.50	4.60	
		50 °C	4.20	---	4.60	
		70 °C	4.00	---	4.50	

LCD Characteristics						
For STN/FSTN LCD Panel Types						
Item	Symbol	Condition	Min	Typ	Max	Unit
Viewing Angle	$\Phi 2 - \Phi 1$	K = 4	40°	---	---	Deg
	Θ		60°			
Contrast Ratio	K	---	---	10	---	---
Response Time (Rise)	TR	---	---	150	250	ms
Response Time (Fall)	TF	---	---	150	250	ms

LED Characteristics						
Item	Symbol	Condition	Min	Typ	Max	Unit
LED Forward Voltage	Vf	25°C If=30mA	---	5.0	---	V
LED Forward Current*	If	25°C	---	30	---	mA
LED Reverse Current	Ir	25°C Vr=5.0V	---	---	20	µA
LED Colour Range	X Coordinate	25°C If=30mA	0.26	---	0.30	---
	Y Coordinate		0.27	---	0.31	---
LED Brightness (Without LCD)	Lv	25°C If=30mA	---	440	---	cd/m ²
LED Brightness Uniformity	Lvmin/Lvmax	25°C If=30mA	70	---	---	Ratio
LED Life Time	---	25°C If=30mA	---	50k	---	Hours

Attention: It is constant current, not constant voltage, which should be applied when driving the LED backlight, please ensure you adhere to this rule.

MC21609AB6W-BNMLW-V2	2 x 16	9mm Character Height	LCD Module
Specification			
Version: 1	Date: 29/09/2016		
Revision			