

(0.50 mm) .0197"

BSH SERIES

BASIC BLADE & BEAM SOCKET

SPECIFICATIONS

For complete specifications and recommended PCB layouts see www.samtec.com?BSH

Insulator Material: Black LCP

Contact Material: Phosphor Bronze

Plating:

Au or Sn over 50 μ" (1.27 μm) Ni

Current Rating: 2 A per pin

(2 pins powered)

Flammability Rating: UL 94 VO

Operating Temp Range: -55 °C to +125 °C

Voltage Rating: 175 VAC

Max Cycles: 100

RoHS Compliant: Yes

PROCESSING

Lead-Free Solderable: Yes

SMT Lead Coplanarity: (0.10 mm) .004" max (030-090) (0.15 mm) .006" max (120-150)*
*(.004" stencil solution may be available; contact IPG@samtec.com)

Board Stacking:

For applications requiring more than two connectors per board or 90 positions or higher, contact ipg@samtec.com

RECOGNITIONS

For complete scope of recognitions see www.samtec.com/quality



ALSO AVAILABLE (MOQ Required)

- 30 μ" (0.76 μm) Gold
- Edge Mount Capability
- 8 mm, 11 mm, 16 mm, 19 mm and 22 mm Stack Height (Caution: Some automatic placement/inspection machines may have component height restrictions. Please consult machinery specifications.) (11 mm, 16 mm, 19 mm and 22 mm not available with 50 positions)

Contact Samtec.

Note: Some lengths, styles and options are non-standard, non-returnable.



Mates with: **BTH**

-020, -040, -060, -090, -100, -120

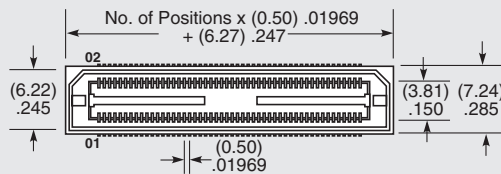

MATED HEIGHT

LEAD STYLE	MATED HEIGHT*
-01	(5.00) .197

*Processing conditions will affect mated height.

- F** = Gold Flash on contact, Matte Tin on tail
 - L** = 10 μ" (0.25 μm) Gold on contact, Matte Tin on tail
 - C*** = Electro-Polished Selective
50 μ" (1.27 μm) min Au over 150 μ" (3.81 μm) Ni on Signal Pins in contact area, Matte Tin over 50 μ" (1.27 μm) min Ni on all solder tails
- *Note: -C Plating passes 10 year MFG testing

POWER/SIGNAL APPLICATION



Compatible with UMPT/UMPS for flexible two-piece power/signal solutions



Mates with: **BTH**

-030, -060, -090

- F** = Gold Flash on contact, Matte Tin on tail
- L** = 10 μ" (0.25 μm) Gold on contact, Matte Tin on tail

-GP = Guide Post

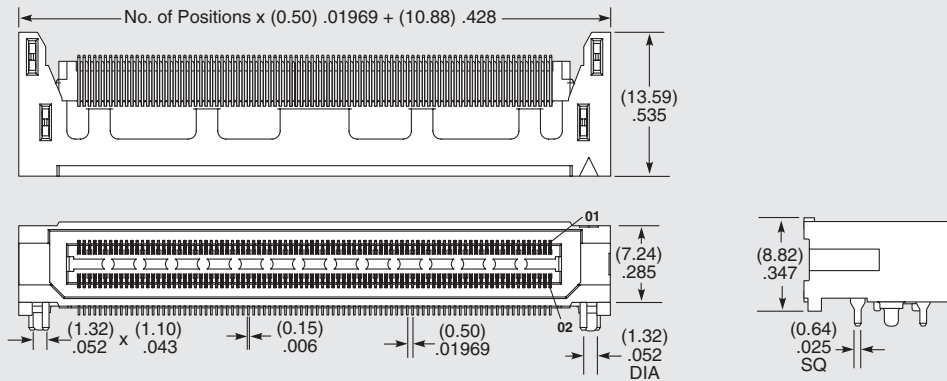

Due to technical progress, all designs, specifications and components are subject to change without notice.