

# Hybrid motor starter - ELR H3-IES-PT/500AC-3-IOL - 2908671

Please be informed that the data shown in this PDF Document is generated from our Online Catalog. Please find the complete data in the user's documentation. Our General Terms of Use for Downloads are valid (<http://phoenixcontact.com/download>)



Networkable hybrid motor starter for starting 3~ AC motors up to 500 V AC and 3 A output current, with adjustable overload shutdown, emergency stop function up to SIL 3/PL e, and Push-in connection. Connection to IO-Link.



## Key Commercial Data

Packing unit	1 STK
GTIN	 4 055626 321264
GTIN	4055626321264
Weight per Piece (excluding packing)	282.700 g
Custom tariff number	85371098
Country of origin	Germany
Note	Made to Order (non-returnable)

## Technical data

### Note

Type of note	Notes on operation
Note	If this device is to be used in combination with the CrossPowerSystem power distribution board, the device mount for the 16 A fuse (order designation: EM-CPS-DA-22,5F/16A; order number: 1002668) is required in order to attach the hybrid motor starter to the power distribution board.

### Device supply

Rated control circuit supply voltage $U_s$	24 V DC
Control supply voltage range	19.2 V DC ... 30 V DC
Rated control supply current $I_s$	65 mA
Type of protection	Surge protection
	Reverse polarity protection

### Input data

Input name	Enable input
------------	--------------

# Hybrid motor starter - ELR H3-IES-PT/500AC-3-IOL - 2908671

## Technical data

### Input data

Rated actuating voltage $U_c$	24 V DC
Triggering voltage range	19.2 V DC ... 30 V DC
Rated actuating current $I_c$	7 mA
Switching threshold	9.6 V ("0" signal)
	19.2 V ("1" signal)
Switching level	< 5 V DC (For EMERGENCY STOP)
Typical turn-off time	< 30 ms

### Output data load output

Output name	AC output
Rated operating voltage $U_e$	500 V AC
Operating voltage range	42 V AC ... 550 V AC
Rated operating current $I_e$	3 A (AC-51)
	3 A (AC-53a)
Mains frequency	50/60 Hz
Load current range	180 mA ... 3 A (see to derating)
Trigger characteristic in acc. with IEC 60947-4-2	Class 10
Cooling time	20 min. (for auto reset)
Leakage current	0 mA
Type of protection	Surge protection

### Overspeed tripping

Operate threshold	> 33 A
Response time	< 0.5 s

### General

Switching frequency	$\leq 2$ Hz (Load-dependent)
Mounting position	vertical (horizontal DIN rail, motor output below)
Mounting type	DIN rail mounting
Assembly instructions	alignable, for spacing see derating
Operating mode	100% operating factor
Maximum power dissipation	4.1 W
Minimum power dissipation	0.88 W
Operating voltage display	Green LED
Status display	Yellow LED
Indication	Red LED

### Connection data, input side

Connection name	Control circuits
Connection method	Push-in connection
Stripping length	10 mm
Conductor cross section solid	0.2 mm <sup>2</sup> ... 2.5 mm <sup>2</sup>
Conductor cross section flexible	0.2 mm <sup>2</sup> ... 2.5 mm <sup>2</sup>

# Hybrid motor starter - ELR H3-IES-PT/500AC-3-IOL - 2908671

## Technical data

### Connection data, input side

Conductor cross section AWG	24 ... 14
-----------------------------	-----------

### Connection data, output side

Connection name	Load circuit
Connection method	Push-in connection
Stripping length	10 mm
Conductor cross section solid	0.2 mm <sup>2</sup> ... 2.5 mm <sup>2</sup>
Conductor cross section flexible	0.2 mm <sup>2</sup> ... 2.5 mm <sup>2</sup>
Conductor cross section AWG	24 ... 14

### Ambient conditions

Ambient temperature (operation)	-5 °C ... 55 °C (observe derating)
Ambient temperature (storage/transport)	-40 °C ... 80 °C
Degree of protection	IP20

### Dimensions

Width	22.5 mm
Height	126.8 mm
Depth	113.7 mm

### UL data

SCCR	100 kA (480 V AC (fuse: 30 A class CC/30 A class J (high fault)))
	5 kA (480 V AC (fuse: 20 A RK5 (standard fault)))
FLA	3 A (480 V AC)
Group installation	20 A (class RK5, SCCR 5kA (480 V AC), #24 - 14 AWG max. solid and stranded)
	30 A (class CC or J, SCCR 100kA (480 V AC), #24 - 14 AWG max, solid and stranded)
Category code	NLDX / NRNT
Horsepower ratings	0.5 hp (120 V AC / 208 V AC)
	1.5 hp (277 V AC / 480 V AC)

### Insulation characteristics

Rated insulation voltage	550 V
Rated surge voltage	6 kV
Overvoltage category	III
Degree of pollution	2
Designation	Insulation characteristics between the control input and control supply voltage, and auxiliary circuit to the main circuit
Insulation	Safe isolation (IEC 60947-1)
Designation	Isolation characteristics between the control input and control supply voltage to auxiliary circuit
Insulation	Safe isolation (IEC 60947-1) in the auxiliary circuit ≤ 300 V AC
	Safe isolation (EN 50178) in the auxiliary circuit ≤ 300 V AC

# Hybrid motor starter - ELR H3-IES-PT/500AC-3-IOL - 2908671

## Technical data

### Standards and Regulations

Designation	Standards/regulations
Standards/regulations	IEC 60947-1
	EN 60947-4-2
	IEC 61508
	ISO 13849

### Approvals/conformities

Safety Integrity Level according to IEC 61508	≤ 3 (Safe shutdown)
Category acc. to EN ISO 13849	≤ 3 (Safe shutdown)
Performance level according to ISO 13849	e (Safe shutdown)
UL certificate	NLDX.E228652
	NRNT.E172140

### Environmental Product Compliance

China RoHS	Environmentally Friendly Use Period = 50
	For details about hazardous substances go to tab "Downloads", Category "Manufacturer's declaration"

## Drawings

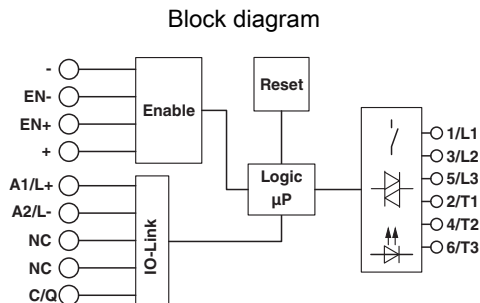

## Classifications

eCl@ss

eCl@ss 5.0	27024002
eCl@ss 5.1	27024002
eCl@ss 6.0	27024002
eCl@ss 7.0	27024002
eCl@ss 8.0	27024002
eCl@ss 9.0	27024002

ETIM

ETIM 2.0	EC001037
ETIM 3.0	EC001037
ETIM 4.0	EC001037

# Hybrid motor starter - ELR H3-IES-PT/500AC-3-IOL - 2908671

## Classifications

### ETIM

ETIM 5.0	EC001037
ETIM 6.0	EC001037

### UNSPSC

UNSPSC 6.01	30211915
UNSPSC 7.0901	39121514
UNSPSC 11	39121514
UNSPSC 12.01	39121514
UNSPSC 13.2	25173902

## Approvals

### Approvals

#### Approvals

UL Listed / UL Listed / cUL Listed / cUL Listed / EAC / cULus Listed

#### Ex Approvals

### Approval details

UL Listed		<a href="http://database.ul.com/cgi-bin/XYV/template/LISEXT/1FRAME/index.htm">http://database.ul.com/cgi-bin/XYV/template/LISEXT/1FRAME/index.htm</a>	FILE E 172140
UL Listed		<a href="http://database.ul.com/cgi-bin/XYV/template/LISEXT/1FRAME/index.htm">http://database.ul.com/cgi-bin/XYV/template/LISEXT/1FRAME/index.htm</a>	FILE E 228652
cUL Listed		<a href="http://database.ul.com/cgi-bin/XYV/template/LISEXT/1FRAME/index.htm">http://database.ul.com/cgi-bin/XYV/template/LISEXT/1FRAME/index.htm</a>	FILE E 172140
cUL Listed		<a href="http://database.ul.com/cgi-bin/XYV/template/LISEXT/1FRAME/index.htm">http://database.ul.com/cgi-bin/XYV/template/LISEXT/1FRAME/index.htm</a>	FILE E 228652
EAC			RU C- DE.A*30.B.01082

# Hybrid motor starter - ELR H3-IES-PT/500AC-3-IOL - 2908671

## Approvals

cULus Listed



## Accessories

### Accessories

#### Adapter

Adapter - EM-CPS-DA-22,5F/16A - 1002668



Device adapter with fuse holder for 16 A fuse (10x38/Class CC), CrossLink® interface and fixed DIN rail

#### Assembly adapter

Power distribution board - EM-CPS-225 - 1002634



Modular power distribution board with CrossLink® interface, 125 A, 3-pos., touch-proof and protection against polarity reversal, width: 225 mm

Power distribution board - EM-CPS-405 - 1002635



Modular power distribution board with CrossLink® interface, 125 A, 3-pos., touch-proof and protection against polarity reversal, width: 405 mm

Connection module - EM-CPS-TB3/63A - 1002633



Connection module with integrated spring-loaded terminals for cables up to 16 mm<sup>2</sup>, 3-pos.,

#### Cover

# Hybrid motor starter - ELR H3-IES-PT/500AC-3-IOL - 2908671

## Accessories

Covering hood - BRIDGE COVER - 2906240



The BRIDGE COVER covering hood is used to cover unused plugs on the CONTACTRON bridge that may subsequently be used to extend the system. The hood can be used with the screw and Push-in version of the bridge.

---

## Loop bridge

Jumper - BRIDGE-PT 2 - 2904490



3-phase loop bridge for 2 CONTACTRON modules, with push-in connection and 22.5 mm housing width, connecting cable: 3 m, with ferrules included.

---

Jumper - BRIDGE-PT 3 - 2904491



3-phase loop bridge for 3 CONTACTRON modules, with push-in connection and 22.5 mm housing width, connecting cable: 3 m, with ferrules included.

---

Jumper - BRIDGE-PT 4 - 2904492



3-phase loop bridge for 4 CONTACTRON modules, with push-in connection and 22.5 mm housing width, connecting cable: 3 m, with ferrules included.

---

Jumper - BRIDGE-PT 5 - 2904493



3-phase loop bridge for 5 CONTACTRON modules, with push-in connection and 22.5 mm housing width, connecting cable: 3 m, with ferrules included.

---

## Hybrid motor starter - ELR H3-IES-PT/500AC-3-IOL - 2908671

### Accessories

Jumper - BRIDGE-PT 6 - 2904494



3-phase loop bridge for 6 CONTACTRON modules, with push-in connection and 22.5 mm housing width, connecting cable: 3 m, with ferrules included.

---

Jumper - BRIDGE-PT 7 - 2904495



3-phase loop bridge for 7 CONTACTRON modules, with push-in connection and 22.5 mm housing width, connecting cable: 3 m, with ferrules included.

---

Jumper - BRIDGE-PT 8 - 2904496



3-phase loop bridge for 8 CONTACTRON modules, with push-in connection and 22.5 mm housing width, connecting cable: 3 m, with ferrules included.

---

Jumper - BRIDGE-PT 9 - 2904497



3-phase loop bridge for 9 CONTACTRON modules, with push-in connection and 22.5 mm housing width, connecting cable: 3 m, with ferrules included.

---

Jumper - BRIDGE-PT 10 - 2904498



3-phase loop bridge for 10 CONTACTRON modules, with push-in connection and 22.5 mm housing width, connecting cable: 3 m, with ferrules included.

---