

Features

DIN-Rail Series

- 2 and 3-phase operation
- Input voltage range: 320 – 575VAC
- Output trim range: 22.5 – 29.5VDC
- High electrical strength; high reliability
- Permanent overload and short-circuit protection
- Parallel operation capability
- International safety certification listing



REDIN960/3AC

**960 Watt
3 Phase
DIN-Rail
Power Supply**



Description

The REDIN/3AC is a series of rugged DIN rail power supplies for two and three-phase mains operation from 320 to 575Vac without the need of a neutral connection. Four versions with a maximum current limited output deliver 5A, 10A, 20A or 40A without derating up to +55°C. The output can be grounded via a third common output terminal. The LED signal on the front panel indicates that the output voltage remains within the wide adjustable range from 22.5 to 29.5Vdc. The units are covered by international safety certificates and are intended for worldwide use. In power-hungry applications, the units can be connected in parallel with no need for additional components.

Selection Guide

Part Number	nom. Input Voltage Range [VAC]	Output Voltage [VDC]	Output Adjustability [VDC]	Rated Current [A]	Efficiency ⁽¹⁾ typ. [%]
REDIN960-24/3AC	400-500	24	22.5-29.5	40	88.5

Notes:

Note1: Efficiency is tested at nominal input and full load at +25°C ambient



Model Numbering

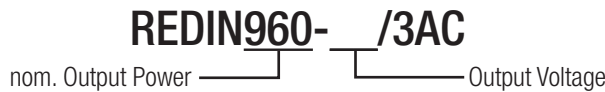

Specifications (measured @ Ta= 25°C, nom.Vin, full load and after warm-up unless otherwise stated)

BASIC CHARACTERISTICS					
Parameter	Condition		Min.	Typ.	Max.
Input Voltage Range	3 phase operation		320VAC	400VAC	575VAC
	2 phase operation		360VAC	400VAC	575VAC
Input Current	3 phase operation	400VAC		3 x 2000mA	
		500VAC		3 x 1600mA	
Input Current	2 phase operation	400VAC		2 x 5300mA	
		500VAC		2 x 4200mA	
Inrush Current					20A
Powerfactor				0.45	
Return Voltage Immunity	24 Vout			35VDC	
No Load Power Consumption					11W
Input Frequency Range	AC Input		45Hz		65Hz
Output Voltage Trimming			22.5VDC		29.5VDC
Minimum Load			0%		
Start-up time	2/3 phase operation, 400VAC				1s
Rise time					2ms
Hold-up time	400VAC		16ms		
	480VAC		20ms		
Output Ripple & Noise	measured at 20MHz BW				40mVp-p

continued on next page



- UL60950-1 certified
- UL508 certified
- EN60950-1 certified
- CSA C22.2 No. 60950-01 certified
- EN55011 compliant
- EN50121-4 compliant
- CSA C22.2 No.107 certified
- EN61000-6-2 compliant
- EN61000-6-3 compliant

Specifications (measured @ Ta= 25°C, nom.Vin, full load and after warm-up unless otherwise stated)

Efficiency vs. Load @ 3 Phase Operation

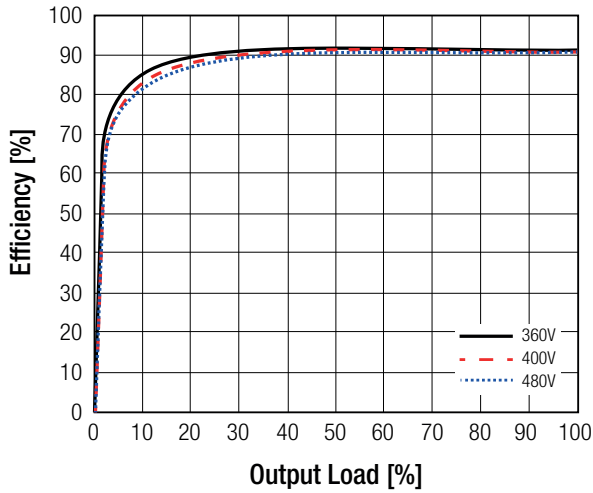

Power Dissipation vs. Load @ 3 Phase Operation

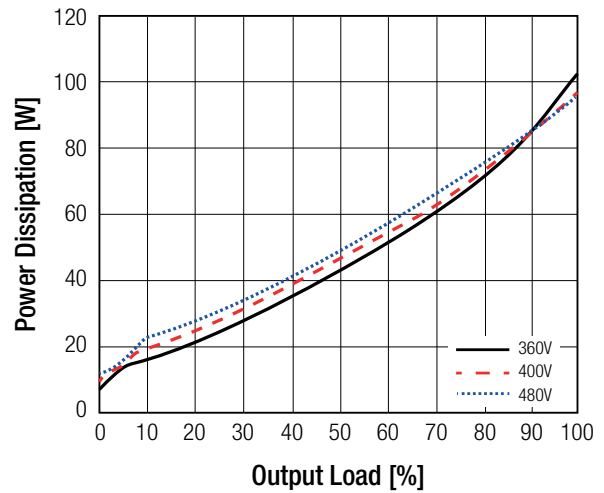

REGULATION

Parameter	Condition	Value
Output Accuracy		±1.0% max.
Line Regulation	10% change in input voltage	±0.1% typ.
Load Regulation	10% - 100% load	±1.0% typ; ±2.0% max.
Transient Response	25% load step change recovery time	200mV typ. 50ms typ.

Accuracy vs. Load

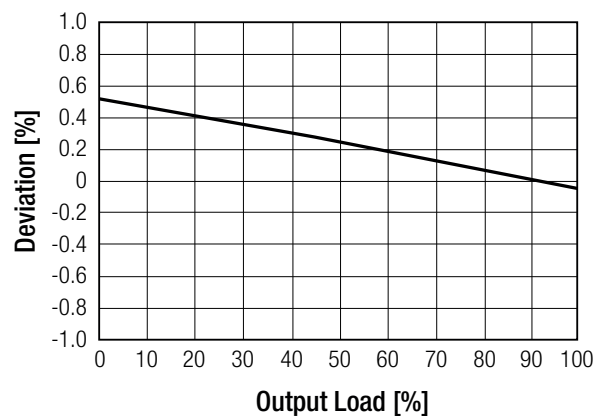

Specifications (measured @ Ta= 25°C, nom.Vin, full load and after warm-up unless otherwise stated)

PROTECTIONS			
Parameter	Type	Value	
Input Fuse	internal	F6.3A, fast blow	
Recommended backup fuse for mains protection		3x 10A (characteristics B) 3x 16A (characteristics B)	
Short Circuit Protection (SCP)	below 100mΩ	>120% typ. power limiting	
Over Voltage Protection (OVP)		>145% typ. auto recovery	
Over Voltage Category (OVC)		OVC II	
Over Temperature Protection (OTP)		refer to note 2	
Over Current Protection (OCP)		>120% typ. auto recovery	
Power OK LED	"DC OK" Light green	Vout >21.5V	
Class of Equipment		Class I	
Isolation Voltage	tested for 1 minute	I/P to O/P	4242VDC
		O/P to PE	2343VDC
Isolation Resistance		10MΩ min.	
Insulation Grade		reinforced	

Notes:

Note2: Under thermal overload conditions, the device does not switch off; instead, the output current is limited as much as necessary to return internal operating temperatures to safe limits. After the device cools down, full output capacity is automatically restored.

ENVIRONMENTAL		
Parameter	Condition	Value
Operating Temperature Range	without derating @ natural convection 0.1m/s (see graph)	-25°C to +55°C
Maximum Case Temperature		+105°C
Temperature Coefficient		±0.05%/°C
Operating Altitude		2000m
Operating Humidity	non-condensing at 25°C	5%-95% RH max.
IP Rating		IP20
Pollution Degree	according to EN50178	PD2
Shock		15G in all directions
Vibration		<15Hz, amplitude ±2.5mm 15Hz to 150Hz, 2.3G, 90min.
MTBF	according to IEC61709	+25°C +55°C 500 x 10 ³ hours 60 x 10 ³ hours

Derating Graph

(@ Chamber and natural convection 0.1m/s)

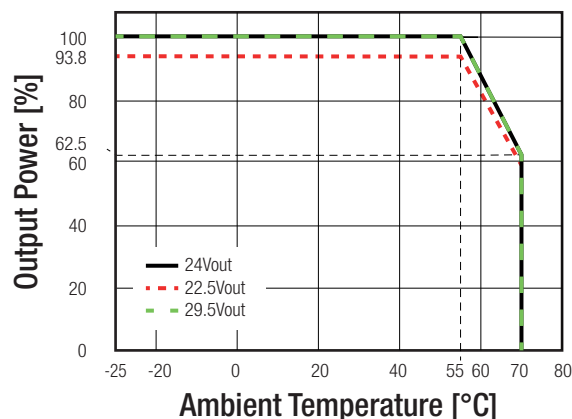

Specifications (measured @ Ta= 25°C, nom.Vin, full load and after warm-up unless otherwise stated)

SAFETY AND CERTIFICATIONS		
Certificate Type	Report / File Number	Standard
Information Technology Equipment, General Requirements for Safety	E196683	UL60950-1, 1st Edition: 2007 CSA C22.2 No. 60950-1, 1st Edition: 2006
Industrial Control Equipment	E470721	UL508, 17th-Edition CSA C22.2 No. 107.1-01, 3rd-Edition
Information Technology Equipment - General Requirments for Safety (LVD)		EN60950-1:2006+A2:2013
EAC	RU-AT.37.02367	TP TC 004/2011
RoHs2		RoHs 2011/65/EU
EMC Compliance		
Report / Condition	Standard / Criterion	
Industrial, scientific and medical equipment – Radio frequency disturbance characteristics – Limits and methods of measurement		EN55011:1989 + A2:2002, Class B
ESD Electrostatic discharge immunity test	Air ±2, 4, 8kV Contact ±2, 4, 6, 8kV	EN61000-4-2:1995 + A1:1998, Criteria A
Radiated, radio-frequency, electromagnetic field immunity test	10V/m (80 - 3000MHz)	EN61000-4-3:2002 + A1:2002, Criteria A
Fast Transient and Burst Immunity	AC Power Port: ±4kV PE ±4kV DC Power Port ±2kV	EN61000-4-4:1995 + A2:2001, Criteria A
Surge Immunity	AC Power Port: L-N ±0.5, 1, 2kV L-PE ±4kV DC Power Port ±0.5, 1, 2kV	EN61000-4-5:1995 + A1:2001, Criteria A
Immunity to conducted disturbances, induced by radio-frequency fields	AC Power Port 10V DC Power Port 10V	EN61000-4-6:1996 + A1:2001, Criteria A
Voltage Dips and Interruptions	Voltage Dips >95%	EN61000-4-11:1994, Criteria B
Voltage Dips and Interruptions	Voltage Dips 60%	EN61000-4-11:1994, Criteria B
Voltage Dips and Interruptions	Voltage Dips 30%	EN61000-4-11:1994, Criteria B
Voltage Dips and Interruptions	Voltage Interruptions > 95%	EN61000-4-11:1994, Criteria B
Limits of Harmonic Current Emissions		EN61000-3-2:2000, Class A
Limits of Voltage Fluctuations & Flicker		EN61000-3-3:1995 + A1:2001
Railway applications – Electromagnetic compatibility Part 4: Emission and immunity of the signalling and telecommunications apparatus		EN50121-4:2006
EMC Compliance (Generic Standards)		
Report / Condition	Standard / Criterion	
Generic standards - Immunity standard for industrial environments		EN61000-6-2:2005
Generic standards - Emission standard for residential, commercial and light-industrial environments		EN61000-6-3:2007 + A1:2011

DIMENSION and PHYSICAL CHARACTERISTICS		
Parameter	Type	Value
Material	cover case	steel sheet, zinc-plated aluminium
Unit Dimension (LxWxH)		190.0 x 139.0 x 130.0 mm
Unit Weight		2900g typ.
continued on next page		

Specifications (measured @ Ta= 25°C, nom.Vin, full load and after warm-up unless otherwise stated)

Dimension Drawing (mm)

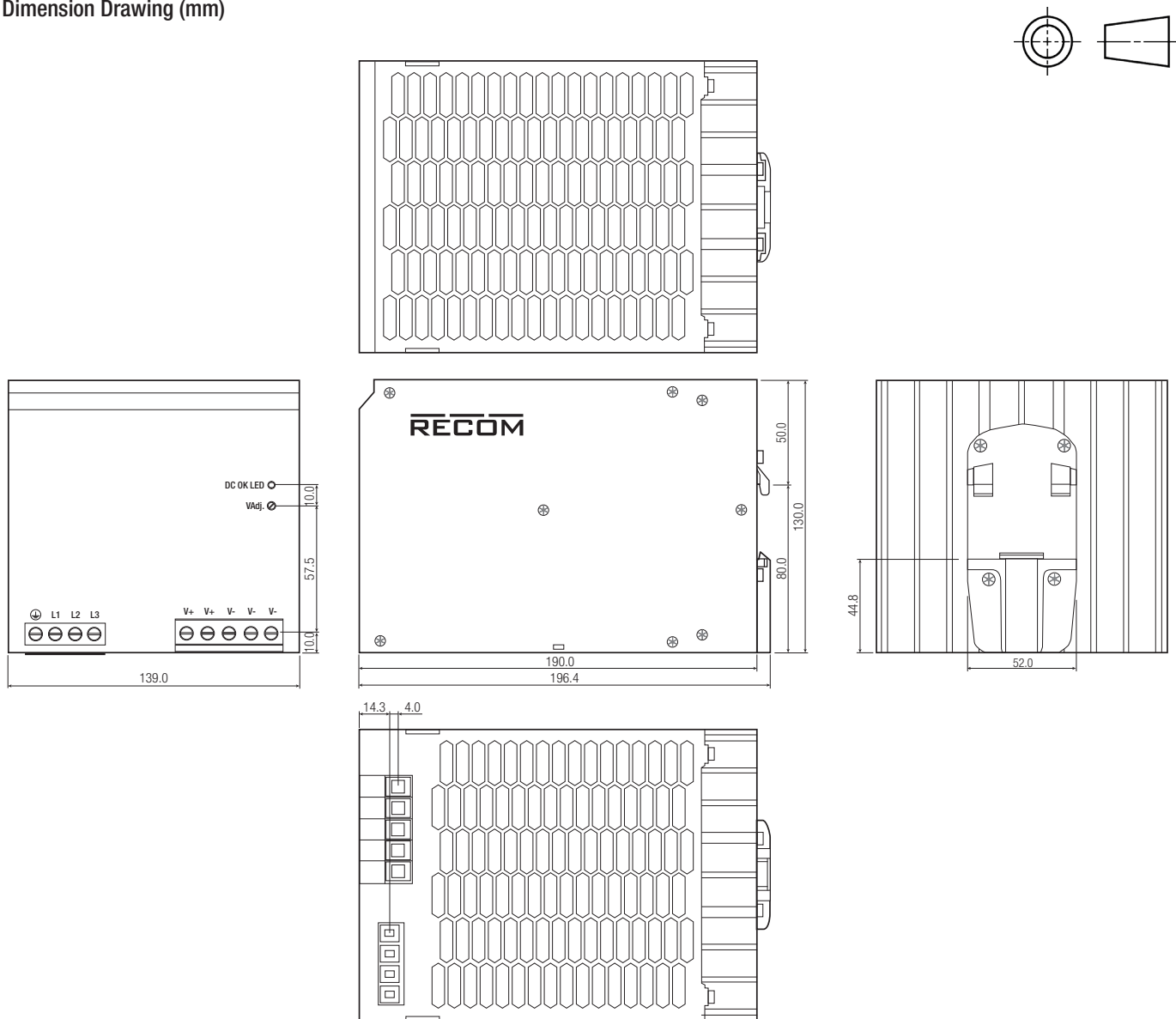

Terminals and Wiring

Type	Screw Connector
Solid Wire Input	0.2 - 6.0mm ²
Solid Wire Output	0.5 - 16.0mm ²
Stranded Wire Input ⁽³⁾	0.2 - 4.0mm ²
Stranded Wire Output ⁽³⁾	0.5 - 10mm ²
American Wire Gauge Input	AWG 22-10
Amerivan Wire Gauge Output	AWG 8-6
Wire Stripping Length Input	9mm
Wire Stripping Length Output	10mm
Screwdriver (slotted / cross)	3.5mm
Recommended tightening torque Input	0.5Nm-0.6Nm
Recommended tightening torque Output	1.2Nm-1.5Nm
Tolerance: X.X ±0.5mm	

Notes:

Note3: The use of sleeve or ferrule terminations is recommended

Specifications (measured @ Ta= 25°C, nom.Vin, full load and after warm-up unless otherwise stated)

INSTALLATION and APPLICATION

Mounting Instruction ⁽⁴⁾

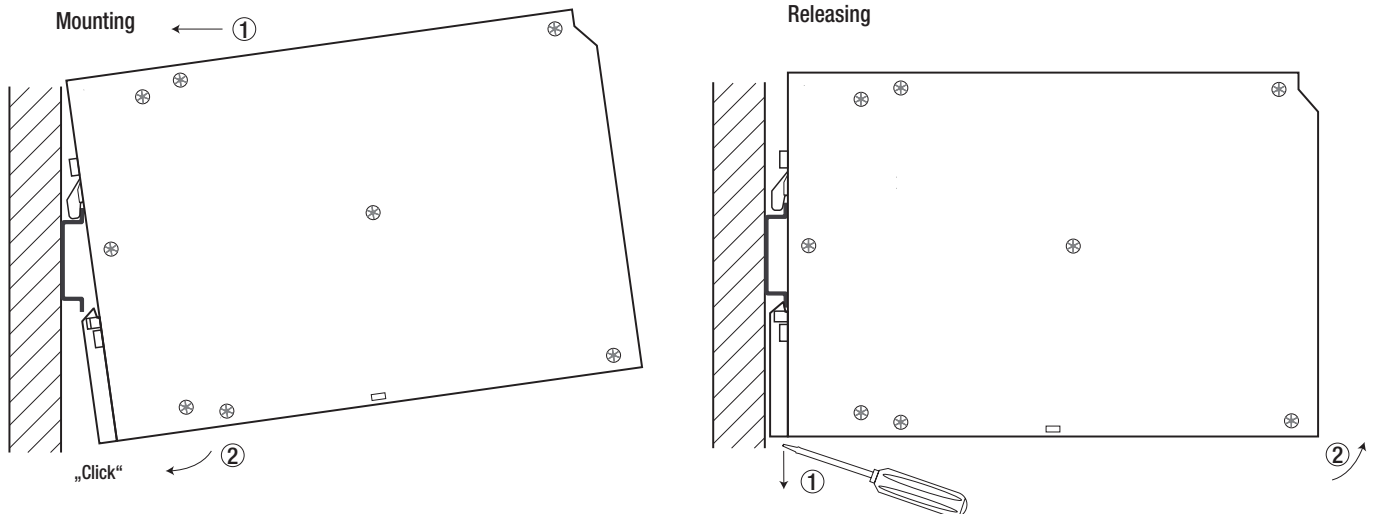

Mounting Multiple Power Supplies ⁽⁵⁾

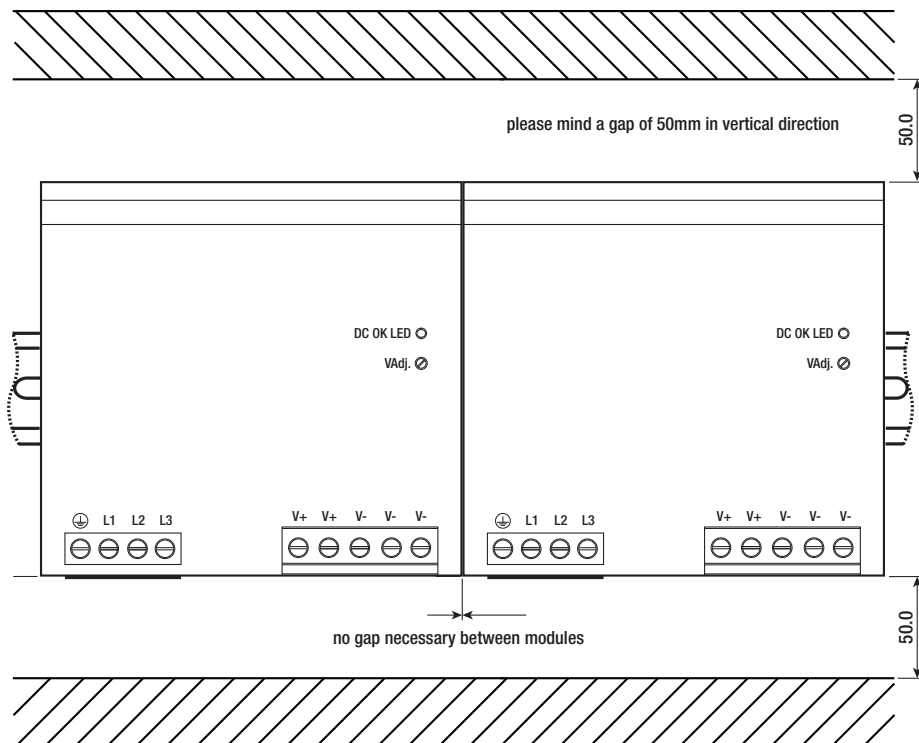

Notes:

Note4: The power supply unit can be snapped onto all DIN Rails in according with EN60715 and has to be mounted vertically

Note5: To guarantee sufficient convection, it is recommended to mint a 50 mm gap in vertical direction

Specifications (measured @ Ta= 25°C, nom.Vin, full load and after warm-up unless otherwise stated)

2 Phase and 3 Phase Operation

3 Phase

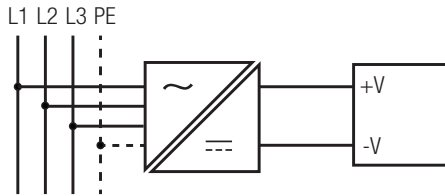

2 Phase

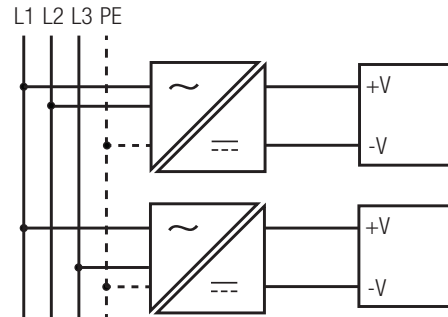

Parallel Operation and Phase Redundancy

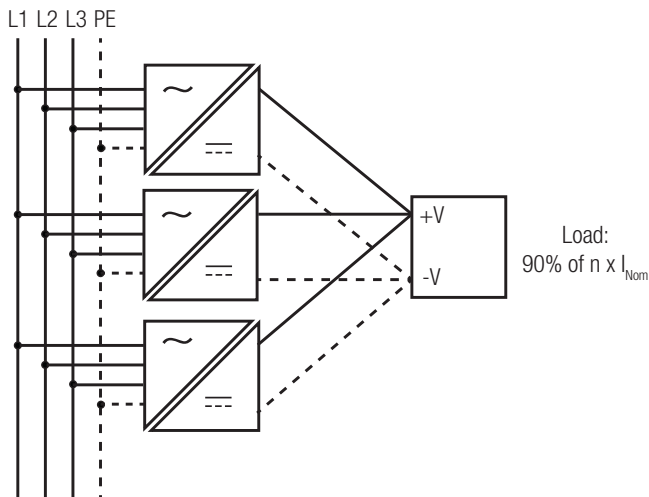

Parallel Operation

- 1) Adjust each power supply to the exact same output voltage with same load and cooling conditions.
- 2) Use the same wire length for each power supply (star connection) and energize all units at the same time to avoid triggering overload protection.
- 3) To prevent high reverse currents in the event of a secondary output fault, it is recommended to install a protective circuit at the output of each device when more than two power supplies are connected in parallel (e.g. decoupling diode or DC fuse).

For n parallel connected devices, the output current can be increased to 90% of $n \times I_{nom}$. A maximum of 5 devices can be connected in parallel.

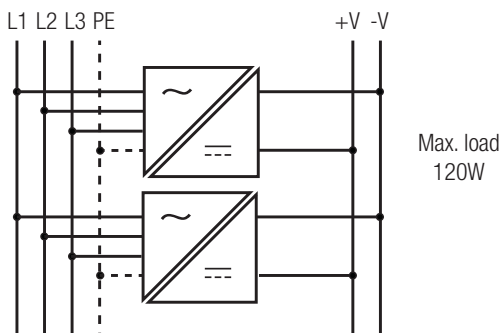

Phase redundancy

- 1) If any single phase fails, operation is still guaranteed.

Specifications (measured @ Ta= 25°C, nom.Vin, full load and after warm-up unless otherwise stated)

Block Diagramm

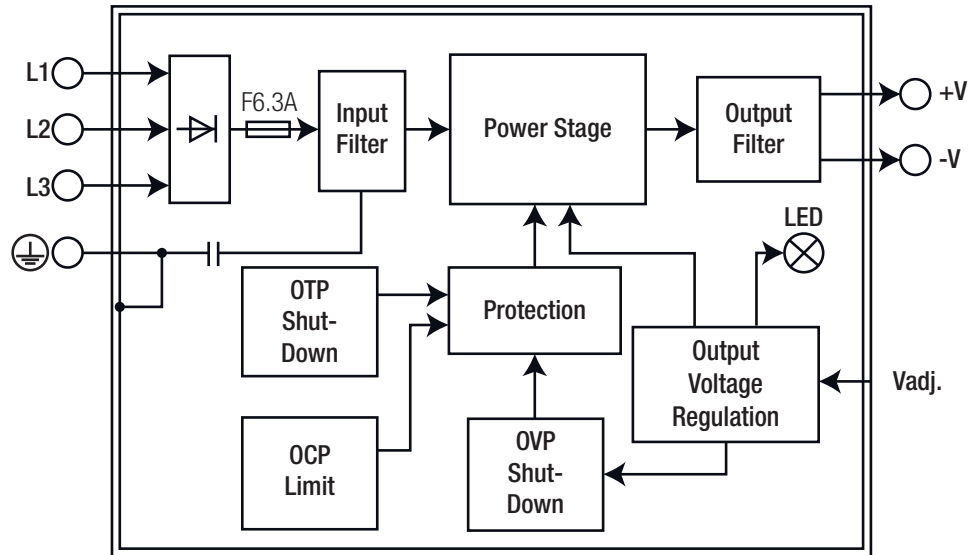

PACKAGING INFORMATION

Parameter	Type	Value
Packaging Dimension (LxWxH)	cardboard box	323.0 x 180.0 x 161.0mm
Packaging Quantity		1 pcs
Storage Temperature Range		-40°C to +85°C
Storage Humidity	non-condensing	95% RH max.

The product information and specifications may be subject to changes even without prior written notice. The product has been designed for various applications; its suitability lies in the responsibility of each customer. The products are not authorized for use in safety-critical applications without RECOM's explicit written consent. A safety-critical application is an application where a failure may reasonably be expected to endanger or cause loss of life, inflict bodily harm or damage property. The applicant shall indemnify and hold harmless RECOM, its affiliated companies and its representatives against any damage claims in connection with the unauthorized use of RECOM products in such safety-critical applications.