

MCT070HDMI-B	1024 x 600	HDMI Interface	TFT Module
Specification			
Version: 3		Date: 22/03/2018	
Revision			
1	24/11/2017	First issue.	
2	26/01/2018	Modify Temperature.	
3	11/06/2018	Modify PCB & Electrical Characteristics.	

Display Features			
Display Size	7.0"		
Resolution	1024 x 600		
VGA Size	WSVGA		
Orientation	Landscape		
Appearance	RGB		
Logic Voltage	5V		
Interface	HDMI		
Brightness	600 cd/m ²		
Touchscreen	N/A		
Module Size	164.80 x 99.80 x 24.80 mm		
Operating Temperature	-20°C ~ +70°C		
Pinout	40 - Way	---	---

Display Accessories	
Part Number	Description

Optional Variants	
Appearances	Voltage
Capacitive Touch Panel Resistive Touch Panel	



Contents

1. Module Classification Information

2. Summary

3. General Specification

4. Interface

5. Contour Drawing

6. Absolute Maximum Ratings

7. Electrical Characteristics

8. Optical Characteristics

9. Reliability

10. Other

MIDAS
design • manufacture • supply



2.Summary

TFT 7.0" is a TN transmissive type color active matrix TFT liquid crystal display that uses amorphous silicon TFT as switching devices. This module is composed of a TFT_LCD module, it is usually designed for industrial application and this module follows RoHS.



3.General Specifications

- Size: 7.0 inch
- Dot Matrix: 1024 x RGBx600(TFT) dots
- Module dimension: 164.8(W) x 99.8(H) x 24.8(D) mm
- Active area: 154.2114 x 85.92 mm
- Dot pitch: 0.1506 x 0.1432 mm
- LCD type: TFT, Normally White, Transmissive
- View Direction: 12 o'clock
- Gray Scale Inversion Direction: 6 o'clock
- Aspect Ratio: 16:9
- Backlight Type: LED, Normally White
- With /Without TP: Without TP
- Interface: HDMI
- Surface: Anti-Glare

*Color tone slight changed by temperature and driving voltage.

MIDAS
design • manufacture • supply



4.Interface

4.1. CON5/CON6

Pin No.	Symbol	Function	Remark
1	3.3V	Raspberry Pi:Power 3.3V	
2	5V	Raspberry Pi:Power 5V	
3	SDA	CTP_SDA (For CTP type Reserved)	
4	5V	Raspberry Pi:Power 5V	
5	SCL	CTP_SCL (For CTP type Reserved)	
6	GND	Raspberry Pi:GND	
7	GPIO04	Raspberry Pi:GPIO04	
8	GPIO14	Raspberry Pi:GPIO14	
9	GND	Raspberry Pi:GND	
10	GPIO15	Raspberry Pi:GPIO15	
11	RST	CTP_RST (For CTP type Reserved)	
12	ACTIVE	GPIO	
13	WAKE	CTP_WAKE (For CTP type Reserved)	
14	GND	Raspberry Pi:GND	
15	INT	CTP_INT (For CTP type Reserved)	
16	GPIO23	Raspberry Pi:GPIO23	
17	3.3V	Power Supply	
18	GPIO24	Raspberry Pi:GPIO24	
19	GPIO10	Raspberry Pi:GPIO10	
20	GND	Raspberry Pi:GND	
21	GPIO09	Raspberry Pi:GPIO09	
22	GPIO25	Raspberry Pi:GPIO25	
23	GPIO11	Raspberry Pi:GPIO11	
24	GPIO08	Raspberry Pi:GPIO08	
25	GND	Raspberry Pi:GND	
26	GPIO07	Raspberry Pi:GPIO07	
27	ID_SD	Raspberry Pi:ID_SD	
28	ID_SC	Raspberry Pi:ID_SC	
29	GPIO05	Raspberry Pi:GPIO05	



30	GND	Raspberry Pi:GND	
31	GPIO06	Raspberry Pi:GPIO06	
32	GPIO12	Raspberry Pi:GPIO12	
33	GPIO13	Raspberry Pi:GPIO13	
34	GND	Raspberry Pi:GND	
35	GPIO19	Raspberry Pi:GPIO19	
36	GPIO16	Raspberry Pi:GPIO16	
37	GPIO26	Raspberry Pi:GPIO26	
38	GPIO20	Raspberry Pi:GPIO20	
39	GND	Raspberry Pi:GND	
40	GPIO21	Raspberry Pi:GPIO21	

4.2. HDMI

Pin No.	Symbol	I/O	Function	Remark
1	Rx2+	I	+LVDS Differential Data Input	
2	GND	P	Ground	
3	Rx2-	I	-LVDS Differential Data Input	
4	Rx1+	I	+LVDS Differential Data Input	
5	GND	P	Ground	
6	Rx1-	I	-LVDS Differential Data Input	
7	Rx0+	I	+LVDS Differential Data Input	
8	GND	P	Ground	
9	Rx0-	I	-LVDS Differential Data Input	
10	RxC+	I	+LVDS Differential Clock Input	
11	GND	P	Ground	
12	RxC-	I	-LVDS Differential Clock Input	
13-14	NC	-	No connection	
15	SCL	I/O	DDC(Data Display Channel) Clock	
16	SDA	I/O	DDC(Data Display Channel) Data	
17	GND	P	Ground	
18	5V	P	Power Supply	
19	Detect	I/O	Hot plug detect	

I: input, O: output, P: Power



4.3. POWER JACK

Pin No.	Symbol	I/O	Function	Remark
1	VLED+	P	Power Supply	
2	VLED-	P	Ground	
3	NC		No connection	

MIDAS

design • manufacture • supply



5. Contour Drawing

1024 x RGB x 600

164.80 (Ø5)
157.20 (VA)
154.2144 (AA)

99.50 (Ø5)
89.41 (VA)
85.92 (AA)

2.74
2.11
3.54

5.65 (Ø5)
24.8MAX
3.58 (Ø5)
6.8MAX
11.7MAX
1.60 (PCB)

2.00MAX

0.60
3.50
163.60 (PCB)
156.60

98.60 (PCB)
91.60

0.60
3.50

Ø2.75PTH
Ø6.20PAD

POWER JACK		HDMI		CON5/CON6			
PIN NO.	SYMBOL	PIN NO.	SYMBOL	Pin	Symbol	Pin	Symbol
1	5V	1	RX2+	1	3.3V	21	GPIO09
2	GND	2	GND	2	5V	22	GPIO25
3	NC	3	RX2-	3	GPIO02	23	GPIO11
		4	RX1+	4	5V	24	GPIO08
		5	GND	5	GPIO03	25	GND
		6	RX1-	6	GND	26	GPIO07
		7	RX0+	7	GPIO04	27	ID_SD
		8	GND	8	GPIO14	28	ID_SC
		9	RX0-	9	GND	29	GPIO05
		10	RXC+	10	GPIO15	30	GND
		11	GND	11	GPIO17	31	GPIO06
		12	RXC-	12	GPIO18	32	GPIO12
		13	NC	13	GPIO27	33	GPIO13
		14	NC	14	GND	34	GND
		15	SCL	15	GPIO22	35	GPIO19
		16	SDA	16	GPIO23	36	GPIO16
		17	GND	17	3.3V	37	GPIO26
		18	5V	18	GPIO24	38	GPIO20
		19	Detect	19	GPIO10	39	GND
				20	GND	40	GPIO21

2 - (GND) 1 - (5V)

The non-specified tolerance of dimension is ±0.3mm.

design • manufacture • supply



6. Absolute Maximum Ratings

Item	Symbol	Min	Typ	Max	Unit
Operating Temperature	TOP	0	—	+70	°C
Storage Temperature	TST	0	—	+80	°C

Note: Device is subject to be damaged permanently if stresses beyond those absolute maximum ratings listed above

1. Temp. $\leq 60^{\circ}\text{C}$, 90% RH MAX. Temp. $> 60^{\circ}\text{C}$, Absolute humidity shall be less than 90% RH at 60°C



7. Electrical Characteristics

7.1. Typical Operation Conditions

Item	Symbol	Values			Unit	Remark
		Min.	Typ.	MAX.		
Power voltage	VDD	4.5	5.0	5.5	V	Note 2

Note 1: Be sure to apply VDD and VGL to the LCD first, and then apply VGH.

Note 2: VDD setting should match the signals output voltage

7.2. Current Consumption

Item	Symbol	Values			Unit	Remark
		Min.	Typ.	MAX.		
	IVCC	-	1000	-	mA	VCC =3.3V
	IVDD	-	1660	-	mA	VDD =5V

MIDAS

design • manufacture • supply



8. Optical Characteristics

Item	Symbol	Condition.	Min	Typ.	Max.	Unit	Remark
Response time	Tr	$\theta=0^\circ$ 、 $\Phi=0^\circ$	-	25	40	.ms	Note 3
	Tf						
Contrast ratio	CR	At optimized viewing angle	600	800	-	-	Note 4
Color Chromaticity	White	Wx	0.26	0.31	0.36	-	Note 2,5,6
		Wy	0.28	0.33	0.38	-	
Viewing angle (Gray Scale Inversion Direction)	Hor.	Θ_R	70	80	-	Deg.	Note 1
		Θ_L	70	80	-		
	Ver.	Φ_T	50	60	-		
		Φ_B	60	70	-		
Brightness	-	-	500	600	-	cd/m ²	Center of display

Ta=25±2°C,

Note 1: Definition of viewing angle range

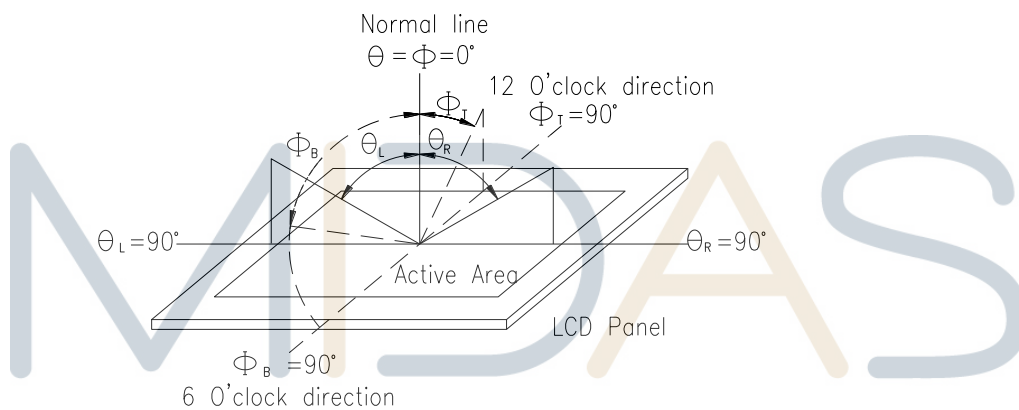

Fig. 8.1. Definition of viewing angle

Note 2: Test equipment setup:

After stabilizing and leaving the panel alone at a driven temperature for 10 minutes, the measurement should be executed. Measurement should be executed in a stable, windless, and dark room. Optical specifications are measured by Topcon BM-7orBM-5 luminance meter 1.0° field of view at a distance of 50cm and normal direction.

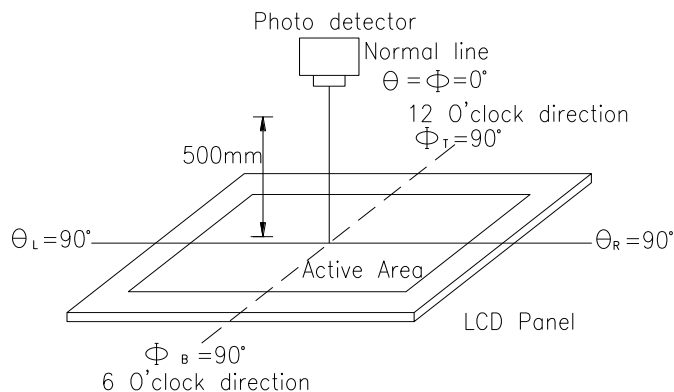
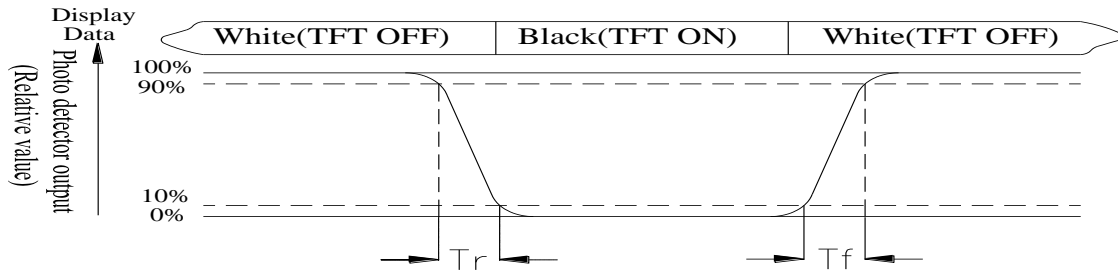

Fig. 8.2. Optical measurement system setup



Note 3: Definition of Response time:

The response time is defined as the LCD optical switching time interval between “White” state and “Black” state. Rise time, T_r , is the time between photo detector output intensity changed from 90% to 10%. And fall time, T_f , is the time between photo detector output intensity changed from 10% to 90%



Note 4: Definition of contrast ratio:

The contrast ratio is defined as the following expression.

$$\text{Contrast ratio (CR)} = \frac{\text{Luminance measured when LCD on the "White" state}}{\text{Luminance measured when LCD on the "Black" state}}$$

Note 5: White $V_i = V_{i50} \pm 1.5V$

Black $V_i = V_{i50} \pm 2.0V$

“±” means that the analog input signal swings in phase with VCOM signal.

“±” means that the analog input signal swings out of phase with VCOM signal.

The 100% transmission is defined as the transmission of LCD panel when all the input terminals of module are electrically opened.

Note 6: Definition of color chromaticity (CIE 1931)

Color coordinates measured at the center point of LCD

Note 7: Measured at the center area of the panel when all the input terminals of LCD panel are electrically opened.



9. Reliability

Content of Reliability Test (Wide temperature, 0°C~70°C)

Environmental Test			
Test Item	Content of Test	Test Condition	Note
High Temperature storage	Endurance test applying the high storage temperature for a long time.	80°C 200hrs	2
Low Temperature storage	Endurance test applying the low storage temperature for a long time.	0°C 200hrs	1,2
High Temperature Operation	Endurance test applying the electric stress (Voltage & Current) and the thermal stress to the element for a long time.	70°C 200hrs	—
Low Temperature Operation	Endurance test applying the electric stress under low temperature for a long time.	0°C 200hrs	1
High Temperature/ Humidity Operation	The module should be allowed to stand at 60°C, 90%RH max	60°C, 90%RH 96hrs	1,2
Thermal shock resistance	The sample should be allowed stand the following 10 cycles of operation <div style="text-align: center;"> <p>0°C 25°C 70°C</p> <p>30min 5min 30min</p> <p>1 cycle</p> </div>	0°C/70°C 10 cycles	—
Vibration test	Endurance test applying the vibration during transportation and using.	Total fixed amplitude : 1.5mm Vibration Frequency : 10~55Hz One cycle 60 seconds to 3 directions of X,Y,Z for Each 15 minutes	3
Static electricity test	Endurance test applying the electric stress to the terminal.	VS=±600V(contact) , ±800v(air), RS=330Ω CS=150pF 10 times	—

Note1: No dew condensation to be observed.

Note2: The function test shall be conducted after 4 hours storage at the normal Temperature and humidity after remove from the test chamber.

Note3: The packing have to including into the vibration testing.



MCIB-HDMI/HDMI		Interconnect Board
Specification		
Version: 1	Date: 16/04/2018	
Revision		
1	16/04/2018	First Release.

Compatible Displays	
Part Number	Description
MCT050HDMI-A-RTP	5" HDMI TFT. Resistive and Capacitive touch, respectively.
MCT050HDMI-A-CTP	
MCT070HDMI-B-RTP	7" HDMI TFT. Resistive and Capacitive touch, respectively.
MCT070HDMI-B-CTP	
MCT101HDMI-A-RTP	10.1" HDMI TFT. Resistive and Capacitive touch, respectively.
MCT101HDMI-A-CTP	

Interconnect Board Description	
	Description
A	Male HDMI Connector

MIDAS

design • manufacture • supply

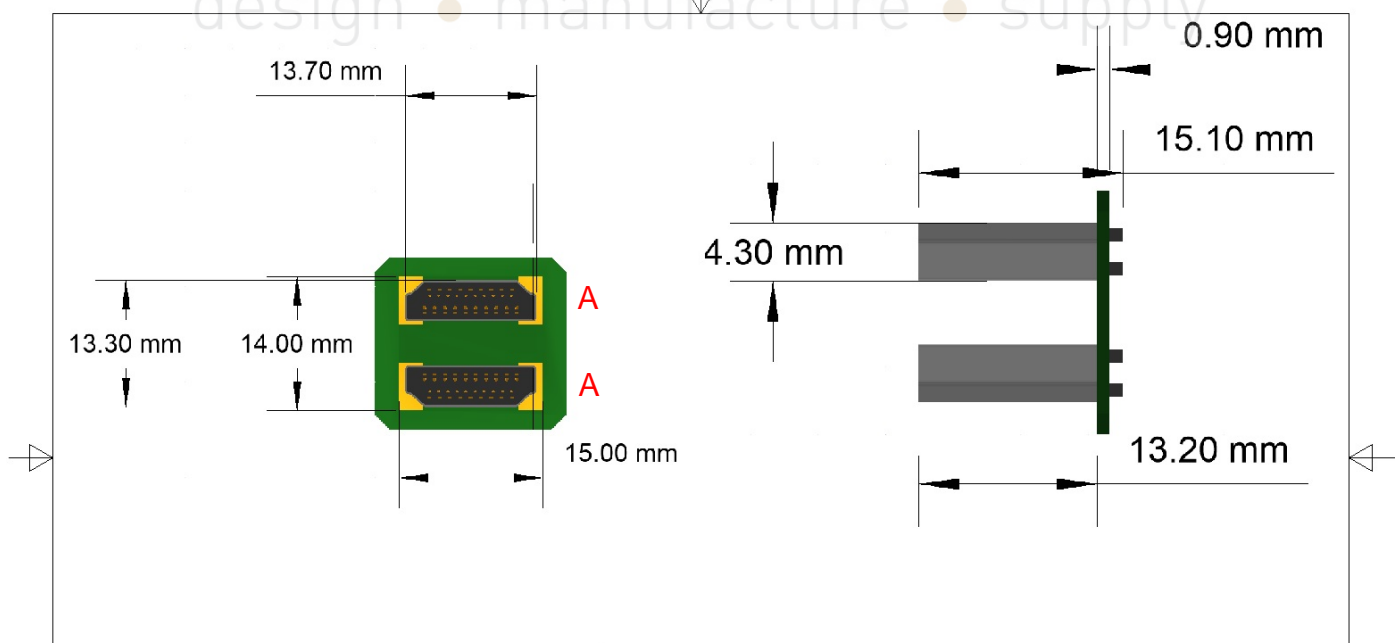

Allow for +/- 2-3mm
for all dimensions.

		Midas Components Ltd	
design • manufacture • supply			
TITLE MCIB-HDMI/HDMI			
SIZE A4	CAGE CODE	DWG NO	REV 1
SCALE 1.5:1	SHEET		



MCIC-USB		Interconnect Cable
Specification		
Version: 1	Date: 16/04/2018	
Revision		
1	16/04/2018	First Release.

Compatible Displays	
Part Number	Description
MCT050HDMI-A-RTP	5" HDMI TFT. Resistive and Capacitive touch, respectively.
MCT050HDMI-A-CTP	
MCT070HDMI-B-RTP	7" HDMI TFT. Resistive and Capacitive touch, respectively.
MCT070HDMI-B-CTP	
MCT101HDMI-A-RTP	10.1" HDMI TFT. Resistive and Capacitive touch, respectively.
MCT101HDMI-A-CTP	

Cable Descriptions	
	Description
A	Type-A USB Connector.
B	Micro-B USB Connector.

MIDAS



design • manufacture • supply

*Allow for +/- 2/3mm for all dimensions.

