

MCT101HDMI-A-CTP	1280 x 800	HDMI Interface	TFT Module
Specification			
Version: 2		Date: 22/03/2018	
Revision			
1	25/01/2018	First issue.	
2	11/06/2018	Modify Electrical Characteristics.	

Display Features					
Display Size	10.1"				
Resolution	1280 x 800				
VGA Size	WXGA				
Orientation	Landscape				
Appearance	RGB				
Logic Voltage	5V				
Interface	HDMI				
Brightness	900 cd/m ²				
Touchscreen	CTP				
Module Size	257.96 x 168.60 x 28.20 mm				
Operating Temperature	-20°C ~ +70°C			Box Quantity	Weight / Display
Pinout	40 - Way			---	---

Display Accessories	
Part Number	Description

Optional Variants	
Appearances	Voltage
Resistive Touch Panel	
No Touch Panel	



Contents

1.Module Classification Information

2.Summary

3.General Specification

4.Interface

5.Contour Drawing

6.Absolute Maximum Ratings

7.Electrical Characteristics

8.Optical Characteristics

9.Reliability

10.Other

MIDAS
design • manufacture • supply



2.Summary

TFT 10.1" is a IPS transmissive type color active matrix TFT liquid crystal display . In-Plane Switching (IPS) was one of the first refinements to produce significant gains in the light-transmissive characteristics of TFT panels. It is a technology that addresses the two main issues of a standard twisted nematic (TN) TFT display: colour and viewing angle.

MIDAS

design • manufacture • supply



3. General Specifications

- Screen Diagonal: 10.1 inch
- Number of Pixels: 1280 x 3(R GB) x 800 dots
- Module dimension: 257.96 x 168.6 x 28.2 mm
- Active area: 216.96 (H) x 135.6(V) mm
- Pixel pitch: 0.1695 x 0.1695 mm
- Display Mode: Normally Black
- Pixel Arrangement: R.G.B. Vertical Stripe
- Backlight Type: LED, Normally White
- Aspect Ratio: 16:9
- Electrical Interface (Logic): HDMI
- With /Without TP: With CTP
- Surface: Glare

*Color tone slight changed by temperature and driving voltage.

design • manufacture • supply



4.Interface

4.1. CON5/CON6

Pin No.	Symbol	Function	Remark
1	3.3V	Raspberry Pi:Power 3.3V	
2	5V	Raspberry Pi:Power 5V	
3	GPIO02	Raspberry Pi:GPIO02	
4	5V	Raspberry Pi:Power 5V	
5	GPIO03	Raspberry Pi:GPIO03	
6	GND	Raspberry Pi:GND	
7	GPIO04	Raspberry Pi:GPIO04	
8	GPIO14	Raspberry Pi:GPIO14	
9	GND	Raspberry Pi:GND	
10	GPIO15	Raspberry Pi:GPIO15	
11	GPIO17	Raspberry Pi:GPIO17	
12	GPIO18	Raspberry Pi:GPIO18	
13	GPIO27	Raspberry Pi:GPIO27	
14	GND	Raspberry Pi:GND	
15	GPIO22	Raspberry Pi:GPIO22	
16	GPIO23	Raspberry Pi:GPIO23	
17	3.3V	Raspberry Pi:3.3V	
18	GPIO24	Raspberry Pi:GPIO24	
19	GPIO10	Raspberry Pi:GPIO10	
20	GND	Raspberry Pi:GND	
21	GPIO09	Raspberry Pi:GPIO09	
22	GPIO25	Raspberry Pi:GPIO25	
23	GPIO11	Raspberry Pi:GPIO11	
24	GPIO08	Raspberry Pi:GPIO08	
25	GND	Raspberry Pi:GND	
26	GPIO07	Raspberry Pi:GPIO07	
27	ID_SD	Raspberry Pi:ID_SD	
28	ID_SC	Raspberry Pi:ID_SC	
29	GPIO05	Raspberry Pi:GPIO05	
30	GND	Raspberry Pi:GND	
31	GPIO06	Raspberry Pi:GPIO06	
32	GPIO12	Raspberry Pi:GPIO12	



33	GPIO13	Raspberry Pi:GPIO13	
34	GND	Raspberry Pi:GND	
35	GPIO19	Raspberry Pi:GPIO19	
36	GPIO16	Raspberry Pi:GPIO16	
37	GPIO26	Raspberry Pi:GPIO26	
38	GPIO20	Raspberry Pi:GPIO20	
39	GND	Raspberry Pi:GND	
40	GPIO21	Raspberry Pi:GPIO21	

4.2. HDMI

Pin No.	Symbol	I/O	Function	Remark
1	Rx2+	I	+LVDS Differential Data Input	
2	GND	P	Ground	
3	Rx2-	I	-LVDS Differential Data Input	
4	Rx1+	I	+LVDS Differential Data Input	
5	GND	P	Ground	
6	Rx1-	I	-LVDS Differential Data Input	
7	Rx0+	I	+LVDS Differential Data Input	
8	GND	P	Ground	
9	Rx0-	I	-LVDS Differential Data Input	
10	RxC+	I	+LVDS Differential Clock Input	
11	GND	P	Ground	
12	RxC-	I	-LVDS Differential Clock Input	
13-14	NC	-	No connection	
15	SCL	I/O	DDC(Data Display Channel) Clock	
16	SDA	I/O	DDC(Data Display Channel) Data	
17	GND	P	Ground	
18	5V	P	Power Supply	
19	Detect	I/O	Hot plug detect	

I: input, O: output, P: Power



4.3. CTP USB PIN Definition

Pin	Symbol	Function	Remark
1	5V	Power Supply (5V)	
2	D-	Data line -	
3	D+	Data line +	
4	NC	No connection	
5	GND	Power Ground	

4.4. POWER-JACK

Pin No.	Symbol	I/O	Function	Remark
1	VDD	P	Power Supply	
2	GND	P	Ground	
3	NC	-	No connection	

MIDAS

design • manufacture • supply



5. Contour Drawing

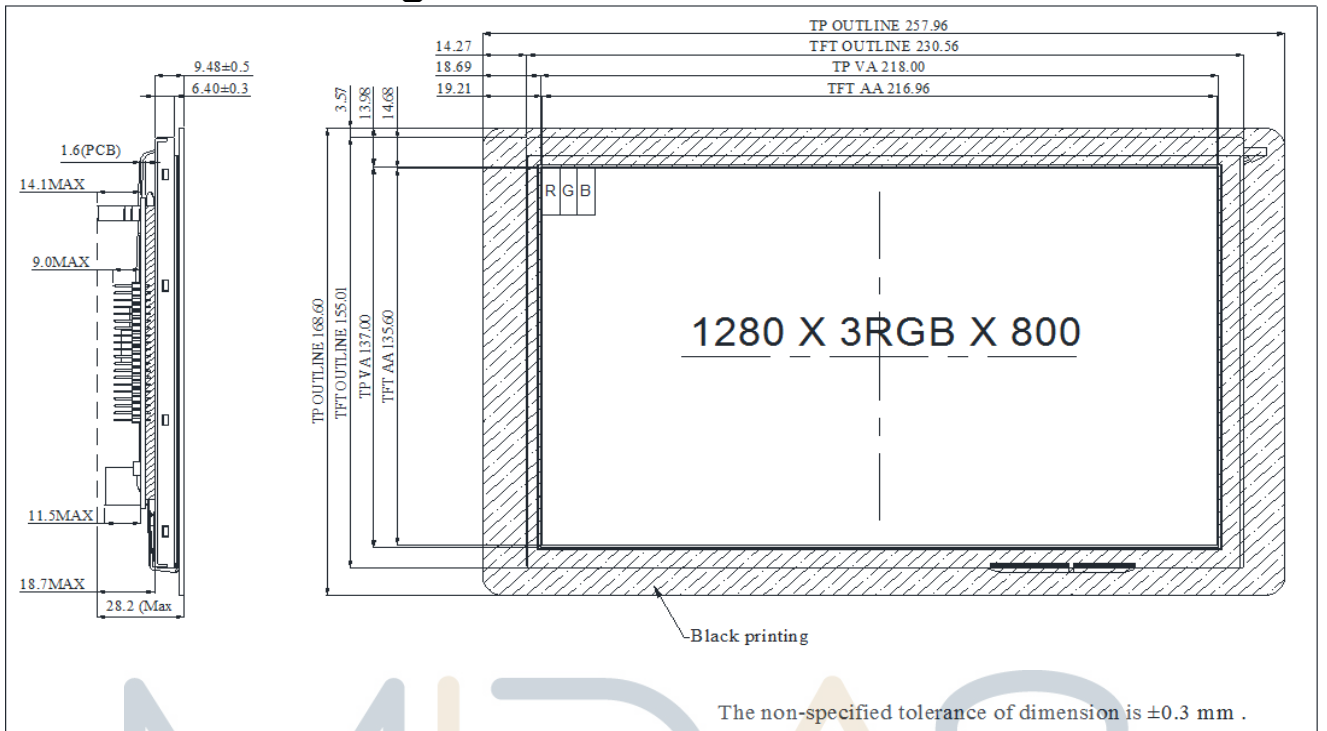

The non-specified tolerance of dimension is ±0.3 mm .

MIDAS

design • manufacture • supply



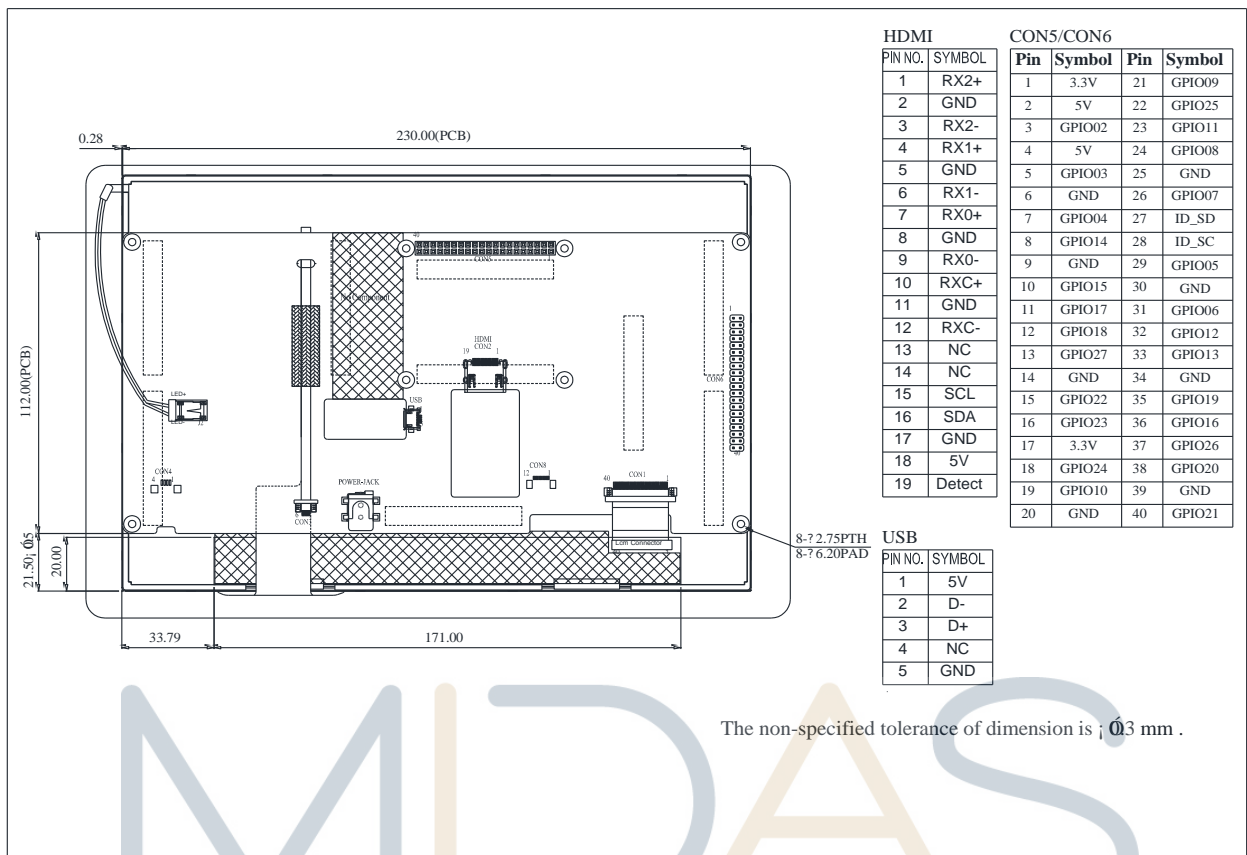

HDMI	
PIN NO.	SYMBOL
1	RX2+
2	GND
3	RX2-
4	RX1+
5	GND
6	RX1-
7	RX0+
8	GND
9	RX0-
10	RXC+
11	GND
12	RXC-
13	NC
14	NC
15	SCL
16	SDA
17	GND
18	5V
19	Detect

CON5/CON6			
Pin	Symbol	Pin	Symbol
1	3.3V	21	GPIO09
2	5V	22	GPIO25
3	GPIO02	23	GPIO11
4	5V	24	GPIO08
5	GPIO03	25	GND
6	GND	26	GPIO07
7	GPIO04	27	ID_SD
8	GPIO14	28	ID_SC
9	GND	29	GPIO05
10	GPIO15	30	GND
11	GPIO17	31	GPIO06
12	GPIO18	32	GPIO12
13	GPIO27	33	GPIO13
14	GND	34	GND
15	GPIO22	35	GPIO19
16	GPIO23	36	GPIO16
17	3.3V	37	GPIO26
18	GPIO24	38	GPIO20
19	GPIO10	39	GND
20	GND	40	GPIO21

USB	
PIN NO.	SYMBOL
1	5V
2	D-
3	D+
4	NC
5	GND

The non-specified tolerance of dimension is ± 0.3 mm .

MIDAS

design • manufacture • supply



6. Absolute Maximum Ratings

Item	Symbol	Min	Typ	Max	Unit
Operating Temperature	TOP	-20	—	+70	°C
Storage Temperature	TST	-20	—	+70	°C

Note: Device is subject to be damaged permanently if stresses beyond those absolute maximum ratings listed above

1. Temp. $\leq 60^{\circ}\text{C}$, 90% RH MAX. Temp. $> 60^{\circ}\text{C}$, Absolute humidity shall be less than 90% RH at 60°C



7. Electrical Characteristics

7.1. Operating conditions:

Item	Symbol	Condition	Min	Typ	Max	Unit	Remark
Supply Voltage For LCM	VDD	—	4.9	5	5.1	V	-
Supply Current For LCM	IDD	—	—	1.65	2.475	A	Note1

Note 1 : This value is test for VDD =5.0V , Ta=25°C only

Note 2 : CTP driver is base on the mouse driver program and through USB port connect to PC or embedded board.Can only support the single touch.



8. Optical Characteristics

Item	Symbol	Condition.	Min	Typ.	Max.	Unit	Remark
Response time	Tr	$\theta=0^\circ, \phi=0^\circ$	-	10	20	.ms	Note 3
	Tf		-	15	30		
Contrast ratio	CR	At optimized viewing angle	600	800	-	-	Note 4
Color Chromaticity	White	Wx	0.26	0.31	0.36	-	Note 2,5
		Wy	0.28	0.33	0.38	-	
Viewing angle (Gray Scale Inversion Direction)	Hor.	Θ_R	75	85	-	Deg.	Note 1
		Θ_L	75	85	-		
	Ver.	Φ_T	75	85	-		
		Φ_B	75	85	-		
Brightness	-	-	800	900	-	cd/m ²	Center of display

Ta=25±2°C

Note 1: Definition of viewing angle range

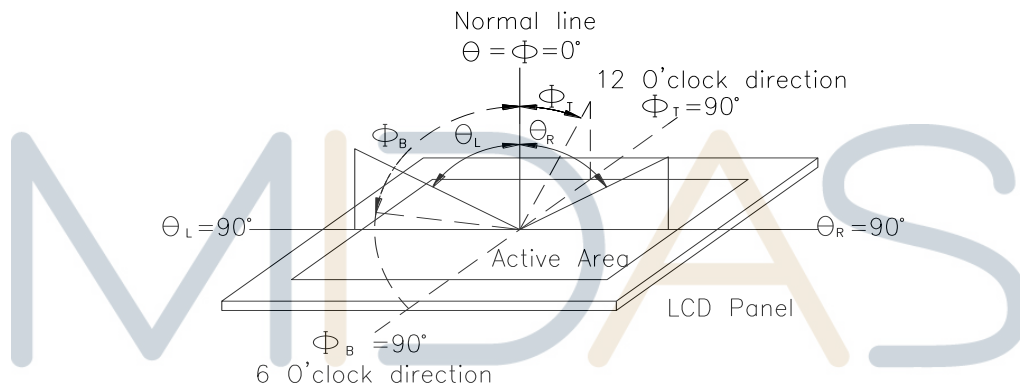

Fig. 8.1. Definition of viewing angle

Note 2: Test equipment setup:

After stabilizing and leaving the panel alone at a driven temperature for 10 minutes, the measurement should be executed. Measurement should be executed in a stable, windless, and dark room. Optical specifications are measured by Topcon BM-7 or BM-5 luminance meter 1.0° field of view at a distance of 50cm and normal direction.

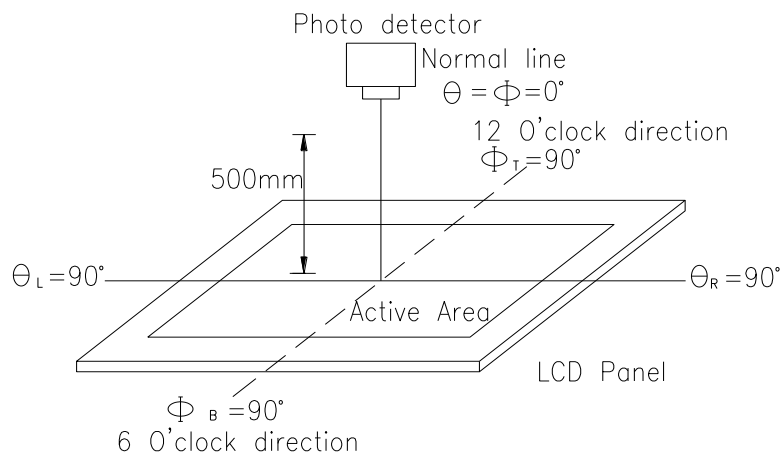
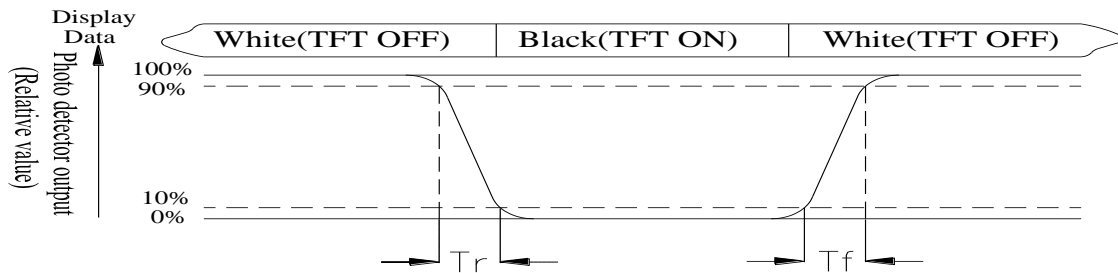

Fig. 8.2. Optical measurement system setup



Note 3: Definition of Response time:

The response time is defined as the LCD optical switching time interval between "White" state and "Black" state. Rise time, T_r , is the time between photo detector output intensity changed from 90% to 10%. And fall time, T_f , is the time between photo detector output intensity changed from 10% to 90%



Note 4: Definition of contrast ratio:

The contrast ratio is defined as the following expression.

$$\text{Contrast ratio (CR)} = \frac{\text{Luminance measured when LCD on the "White" state}}{\text{Luminance measured when LCD on the "Black" state}}$$

Note 5: White $V_i = V_{i50} \pm 1.5V$

Black $V_i = V_{i50} \pm 2.0V$

"±" means that the analog input signal swings in phase with VCOM signal.

"±" means that the analog input signal swings out of phase with VCOM signal.

The 100% transmission is defined as the transmission of LCD panel when all the input terminals of module are electrically opened.

Note 6: Definition of color chromaticity (CIE 1931)

Color coordinates measured at the center point of LCD

Note 7: Measured at the center area of the panel when all the input terminals of LCD panel are electrically opened.

design • manufacture • supply



9. Reliability

Content of Reliability Test (Wide temperature, -20°C~70°C)

Environmental Test			
Test Item	Content of Test	Test Condition	Note
High Temperature storage	Endurance test applying the high storage temperature for a long time.	70°C 200hrs	2
Low Temperature storage	Endurance test applying the low storage temperature for a long time.	-20°C 200hrs	1,2
High Temperature Operation	Endurance test applying the electric stress (Voltage & Current) and the thermal stress to the element for a long time.	70°C 200hrs	—
Low Temperature Operation	Endurance test applying the electric stress under low temperature for a long time.	-20°C 200hrs	1
High Temperature/ Humidity Operation	The module should be allowed to stand at 60°C, 90%RH max	60°C, 90%RH 96hrs	1,2
Thermal shock resistance	The sample should be allowed stand the following 10 cycles of operation <div style="text-align: center;"> <p style="margin: 0;">-20°C 25°C 70°C</p> <p style="margin: 0;">30min 5min 30min</p> <p style="margin: 0;">1 cycle</p> </div>	-20°C/70°C 10 cycles	—
Vibration test	Endurance test applying the vibration during transportation and using.	Total fixed amplitude : 1.5mm Vibration Frequency : 10~55Hz One cycle 60 seconds to 3 directions of X,Y,Z for Each 15 minutes	3
Static electricity test	Endurance test applying the electric stress to the terminal.	VS=±600V(contact) , ±800v(air), RS=330Ω CS=150pF 10 times	—

Note1: No dew condensation to be observed.

Note2: The function test shall be conducted after 4 hours storage at the normal Temperature and humidity after remove from the test chamber.

Note3: The packing have to including into the vibration testing.



MCIB-HDMI/HDMI		Interconnect Board	
Specification			
Version: 1		Date: 16/04/2018	
Revision			
1	16/04/2018	First Release.	

Compatible Displays	
Part Number	Description
MCT050HDMI-A-RTP	5" HDMI TFT. Resistive and Capacitive touch, respectively.
MCT050HDMI-A-CTP	
MCT070HDMI-B-RTP	7" HDMI TFT. Resistive and Capacitive touch, respectively.
MCT070HDMI-B-CTP	
MCT101HDMI-A-RTP	10.1" HDMI TFT. Resistive and Capacitive touch, respectively.
MCT101HDMI-A-CTP	

Interconnect Board Description	
	Description
A	Male HDMI Connector

MIDAS

design • manufacture • supply

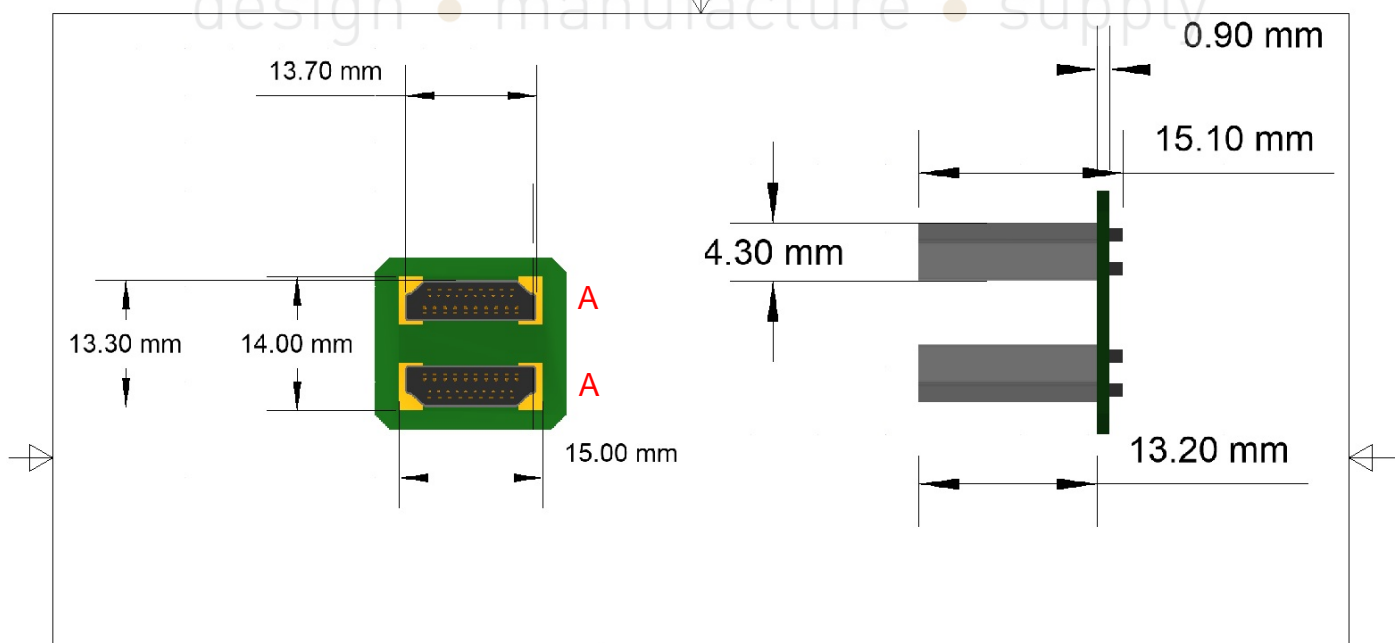

Allow for +/- 2-3mm
for all dimensions.

		Midas Components Ltd	
TITLE			
MCIB-HDMI/HDMI			
SIZE	CAGE CODE	DWG NO	REV
A4			1
SCALE	1.5:1		SHEET



MCIC-USB		Interconnect Cable
Specification		
Version: 1		Date: 16/04/2018
Revision		
1	16/04/2018	First Release.

Compatible Displays	
Part Number	Description
MCT050HDMI-A-RTP MCT050HDMI-A-CTP	5" HDMI TFT. Resistive and Capacitive touch, respectively.
MCT070HDMI-B-RTP MCT070HDMI-B-CTP	7" HDMI TFT. Resistive and Capacitive touch, respectively.
MCT101HDMI-A-RTP MCT101HDMI-A-CTP	10.1" HDMI TFT. Resistive and Capacitive touch, respectively.

Cable Descriptions	
	Description
A	Type-A USB Connector.
B	Micro-B USB Connector.

MIDAS



design • manufacture • supply

*Allow for +/- 2/3mm for all dimensions.

