

DELKIN DEVICES®

S330 Series

SATA III Industrial 2.5"

Solid State Drive

Engineering Specification

Document Number: 401-0236-00

Revision: B



Product Overview

- **Capacity**
 - 16GB up to 256GB
- **SATA Interface**
 - SATA Revision 3.2
 - SATA 1.5Gbps, 3Gbps, and 6Gbps interface
- **Flash Interface**
 - Flash type: SLC
- **Performance**
 - Read: up to 330 MB/s
 - Write: up to 310 MB/s
- **Power Consumption**^{Note1}
 - Write: < 3,750mW
 - Read: < 3,000mW
 - Idle: < 250mW
- **TBW (Terabytes Written)**^{Note2}
 - 14,600 for 256GB
- **MTBF**
 - More than 2,000,000 hours
- **Features**
 - Static and Dynamic Wear Leveling
 - Bad Block Management
 - TRIM
 - NCQ
 - SMART
 - Over-Provisioning (Option)
 - Firmware Update Capability
 - Temperature Sensor
 - AES Encryption
- **Low Power Management**
 - DIPM/HIPM Mode
- **Temperature Range**
 - Operation: -40°C ~ 85°C
 - Storage: -50°C ~ 100°C
- **RoHS compliant**

Notes:

1. Please see "4.2 Power Consumption" for details.
2. Please see "TBW (Terabytes Written)" in Chapter 2" for details.

TABLE OF CONTENTS

| | | |
|-----------|--|-----------|
| 1. | INTRODUCTION..... | 5 |
| 1.1. | General Description..... | 5 |
| 1.2. | Product Block Diagram..... | 5 |
| 1.3. | Flash Management..... | 5 |
| 1.3.1. | <i>Error Correction Code (ECC)</i> | 5 |
| 1.3.2. | <i>Wear Leveling</i> | 6 |
| 1.3.3. | <i>Bad Block Management</i> | 6 |
| 1.3.4. | <i>TRIM</i> | 6 |
| 1.3.5. | <i>SMART</i> | 6 |
| 1.3.6. | <i>Over-Provisioning</i> | 7 |
| 1.3.7. | <i>Firmware Upgrades</i> | 7 |
| 1.4. | Low Power Management..... | 7 |
| 1.4.1. | <i>DIPM/HIPM Mode</i> | 7 |
| 1.5. | Power Loss Protection: Flushing Mechanism..... | 7 |
| 1.6. | Advanced Device Security Features | 8 |
| 1.6.1. | <i>Secure Erase</i> | 8 |
| 1.6.2. | <i>Write Protect</i> | 8 |
| 1.6.3. | <i>AES Encryption</i> | 8 |
| 1.7. | SSD Lifetime Management..... | 9 |
| 1.7.1. | <i>Terabytes Written (TBW)</i> | 9 |
| 1.7.2. | <i>Thermal Monitor</i> | 9 |
| 1.8. | An Adaptive Approach to Performance Tuning | 10 |
| 1.8.1. | <i>Throughput</i> | 10 |
| 1.8.2. | <i>Predict & Fetch</i> | 10 |
| 2. | PRODUCT SPECIFICATIONS | 11 |
| 3. | ENVIRONMENTAL SPECIFICATIONS..... | 13 |
| 3.1. | Environmental Conditions..... | 13 |
| 3.1.1. | <i>Temperature and Humidity</i> | 13 |
| 3.1.2. | <i>Shock & Vibration</i> | 13 |
| 3.1.3. | <i>Electrostatic Discharge (ESD)</i> | 13 |
| 3.2. | MTBF..... | 13 |
| 3.3. | Certification & Compliance | 13 |

| | | |
|-----------|---|-----------|
| 4. | ELECTRICAL SPECIFICATIONS | 14 |
| 4.1. | Supply Voltage | 14 |
| 4.2. | Power Consumption | 14 |
| 5. | INTERFACE..... | 15 |
| 5.1. | Pin Assignment and Descriptions | 15 |
| 6. | SUPPORTED COMMANDS | 16 |
| 6.1. | ATA Command List..... | 16 |
| 6.2. | Identify Device Data | 17 |
| 6.3. | SMART | 21 |
| 6.3.1. | <i>Command Description</i> | <i>21</i> |
| 6.3.1.1. | <i>I/O Registers</i> | <i>21</i> |
| 6.3.1.2. | <i>SMART Command Table.....</i> | <i>22</i> |
| 6.3.1.3. | <i>SMART Read Attribute</i> | <i>23</i> |
| 6.3.1.4. | SMART READ ATTRIBUTE THRESHOLDS..... | 25 |
| 6.3.1.5. | SMART ENABLE ATTRIBUTE AUTO SAVE..... | 26 |
| 6.3.1.6. | SMART DISABLE ATTRIBUTE AUTO SAVE..... | 27 |
| 6.3.1.7. | SMART EXECUTE OFF-LINE IMMEDIATE | 29 |
| 6.3.1.8. | SMART READ LOG..... | 30 |
| 6.3.1.9. | SMART WRITE LOG | 31 |
| 6.3.1.10. | SMART ENABLE OPERATIONS | 32 |
| 6.3.1.11. | SMART DISABLE OPERATIONS | 34 |
| 6.3.1.12. | SMART RETURN STATUS | 35 |
| 7. | PHYSICAL DIMENSIONS | 36 |

LIST OF TABLES

| | | |
|------------------|---|-----------|
| Table 4-1 | Supply Voltage..... | 14 |
| Table 4-2 | Power Consumption | 14 |
| Table 5-1 | Signal Segment Pin Assignment and Descriptions..... | 15 |
| Table 6-1 | ATA Command List..... | 16 |
| Table 6-2 | List of Device Identification..... | 17 |
| Table 6-3 | List of Device Identification for Each Capacity..... | 20 |
| Table 6-4 | Command Block Registers Addressing | 21 |

1. INTRODUCTION

1.1. General Description

Delkin's S330 Series Industrial 2.5" Solid State Drive (SSD) delivers all the advantages of flash disk technology with the performance of the Serial ATA III interface and is fully compliant with the standard 2.5" form factor. Delkin's SSD draws significantly less power compared to traditional hard drives and is also hot swappable. The drive is available in high endurance SLC capacities from 16GB to 256GB and can reach speeds up to 330MB/s read as well as 310MB/s write (measured by CrystalDiskMark v3.0).

1.2. Product Block Diagram

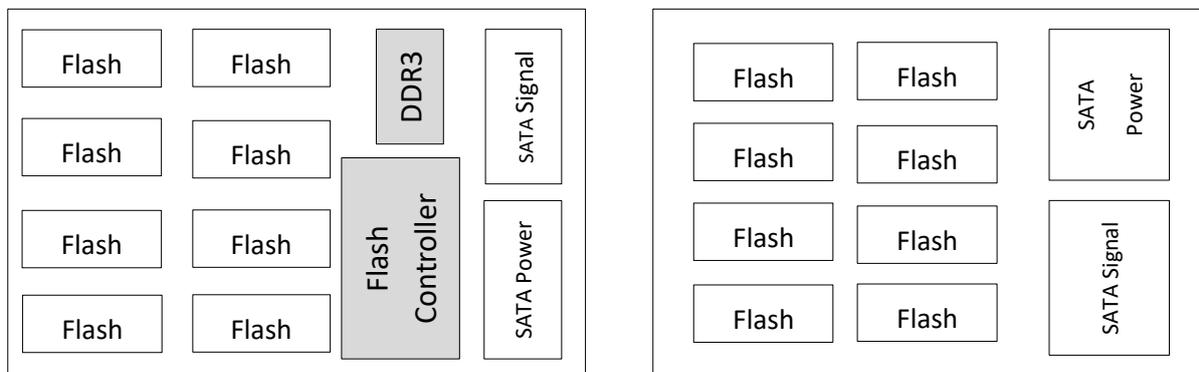

Figure 1-1 SSD Product Block Diagram

1.3. Flash Management

1.3.1. Error Correction Code (ECC)

Flash memory cells will deteriorate with use, which might generate random bit errors in the stored data. Thus, Delkin's Industrial 2.5" SSD applies the BCH ECC algorithm, which can detect and correct errors occur during read process, ensure data been read correctly, as well as protect data from corruption.

1.3.2. Wear Leveling

NAND flash devices can only undergo a limited number of program/erase cycles, and in most cases, the flash media are not used evenly. If some areas are updated more frequently than others, the lifetime of the device would be reduced significantly. Thus, Wear Leveling is applied to extend the lifespan of NAND flash by evenly distributing write and erase cycles across the media.

Delkin utilizes advanced Wear Leveling algorithms, which can efficiently distribute flash usage through the whole flash media area. Moreover, by implementing both dynamic and static Wear Leveling algorithms, the life expectancy of the NAND flash is greatly improved.

1.3.3. Bad Block Management

Bad blocks are blocks that include one or more invalid bits, and their reliability is not guaranteed. Blocks that are identified and marked as bad by the manufacturer are referred to as "Initial Bad Blocks". Bad blocks that are developed during usage of the flash are named "Later Bad Blocks". Delkin implements an efficient bad block management algorithm to detect the factory-produced bad blocks and manages any bad blocks that appear with use. This practice further prevents data being stored into bad blocks and improves data reliability.

1.3.4. TRIM

TRIM is a feature which helps improve the read/write performance and speed of solid-state drives (SSD). Unlike hard disk drives (HDD), SSDs are not able to overwrite existing data, so the available space gradually becomes smaller with each use. With the TRIM command, the operating system can inform the SSD which blocks of data are no longer in use and can be removed permanently. Thus, the SSD will perform an erase action, which prevents unused data from occupying blocks.

1.3.5. SMART

SMART, an acronym for Self-Monitoring, Analysis and Reporting Technology, is an open standard that allows a drive to automatically detect its health and report potential failures. When a failure is recorded by SMART, users can choose to replace the drive to prevent unexpected outage or data loss. Moreover, SMART can inform users of impending failures while there is still time to perform proactive actions, such as copy data to another device.

1.3.6. Over-Provisioning

Over Provisioning refers to the inclusion of extra NAND capacity in a SSD, which is not visible or usable by users. With Over Provisioning, the performance and IOPS (Input/Output Operations per Second) are improved by providing the controller additional space to manage P/E cycles, which enhances the reliability and endurance as well. Moreover, the write amplification of the SSD becomes lower when the controller writes data to the flash. Contact Delkin regarding this customization option.

1.3.7. Firmware Upgrades

Firmware can be considered as a set of instructions on how the device communicates with the host. Firmware can be upgraded when new features are added, compatibility issues are fixed, or read/write performance gets improved, as controlled by the user. Contact Delkin for details.

1.4. Low Power Management

1.4.1. DIPM/HIPM Mode

SATA interfaces contain two low power management states for power saving: Partial and Slumber modes. In Partial mode, the device must resume full operation within 10 microseconds, whereas in Slumber mode, the device has 10 milliseconds to become fully operational. SATA interfaces allow low power modes to be initiated by Host (HIPM, Host Initiated Power Management) or Device (DIPM, Device Initiated Power Management). As for HIPM, Partial or Slumber mode can be invoked directly by the software. For DIPM, the device will send requests to enter Partial or Slumber mode.

1.5. Power Loss Protection: Flushing Mechanism

Power Loss Protection is a mechanism to prevent data loss during unexpected power failures. DRAM is volatile memory and frequently used as temporary cache or buffer between the controller and the NAND flash to improve SSD performance. However, one major concern of the DRAM is that data could be lost in the event of a power failure. Accordingly, the Delkin SATA controller applies the GuaranteedFlush technology, which requests the controller to transfer data to the cache. Only when the data is fully committed to the NAND flash will the controller send acknowledgement (ACK) to the host. Such implementation can prevent false-positive performance and the risk of power cycling issues.

Additionally, it is critical for a controller to shorten the time the in-flight data stays in the cache. Thus, Delkin's controller applies an algorithm to reduce the amount of data residing in the cache to provide better performance. This SmartCacheFlush technology allows incoming data to have only a brief "pit stop" in the cache and then move straight to the NAND flash. If the flash is jammed due to particular file sizes (such as random 4KB data), the cache will be treated as an "organizer", consolidating incoming data into groups before written into the flash to improve write amplification.

In summary, with this advanced Flush Mechanism, Delkin's controller provides the reliability and data protection required by today's applications and hosts.

1.6. Advanced Device Security Features

1.6.1. Secure Erase

Secure Erase is a standard ATA command and will write "0xFF" to all cells, to fully wipe all the data on hard drives and SSDs. When this command is issued, the SSD controller will erase its storage blocks and return to its factory default settings.

1.6.2. Write Protect

When a SSD contains too many bad blocks and data is continuously written in, then the SSD may no longer be usable. Thus, Write Protect is a mechanism to prevent data from being written in and protect the accuracy of data that are already stored in the SSD.

1.6.3. AES Encryption

For applications requiring an extra level of security, the Delkin Utility+ SSD is available with encryption capability, utilizing an AES-XTS 256bit engine.

1.7. SSD Lifetime Management

1.7.1. Terabytes Written (TBW)

TBW (Terabytes Written) is a measurement of SSDs' expected lifespan, which represents the amount of data written to the device. To calculate the TBW of a SSD, the following equation is applied:

$$TBW = [(NAND\ Endurance) \times (SSD\ Capacity) \times (WLE)] / WAF$$

NAND Endurance: NAND endurance refers to the P/E (Program/Erase) cycle rating of NAND flash, per the manufacturer's specification.

SSD Capacity: The SSD capacity is the specific capacity in total of a SSD.

WLE: Wear Leveling Efficiency (WLE) represents the ratio of the average amount of erases on all the blocks to the erases on any block at maximum.

WAF: Write Amplification Factor (WAF) is a numerical value representing the ratio between the amount of data that a SSD controller writes to the flash and the amount of data that the host's flash controller writes. A better WAF, which is near 1, guarantees better endurance and lower frequency of data written to flash memory.

1.7.2. Thermal Monitor

Thermal monitors are devices for measuring temperature, and can be found in SSDs in order to issue warnings when SSDs go beyond a certain temperature. The higher temperature the thermal monitor detects, the more power the SSD consumes, causing the SSD to age quickly. Hence, the processing speed of a SSD should be under control to prevent temperature from exceeding a certain range. Temperature can be monitored via SMART, as referenced in Section 6.3.

1.8. An Adaptive Approach to Performance Tuning

1.8.1. Throughput

Based on the available space of the disk, Delkin SSD controller will regulate the read/write speed and manage the throughput performance. When significant free space remains, the firmware will continuously perform read/write activity. At this stage, there is still no need to implement garbage collection to allocate and release memory, which will accelerate read/write processing to improve the performance. However, when free space is used up, the controller will slow down the read/write processing, and implement garbage collection to release memory blocks. Hence, read/write performance will become slower.

1.8.2. Predict & Fetch

Normally, when the host tries to read data from the SSD, the SSD will only perform one read action after receiving one command. However, Delkin's controller applies Predict & Fetch to improve the read speed. When the host issues sequential read commands to the SSD, the SSD will automatically expect that the following will also be read commands. Thus, before receiving the next command, flash has already prepared the data. Accordingly, this accelerates the data processing time, and the host does not need to wait as long to receive data.

2. PRODUCT SPECIFICATIONS

- **Capacity**
 - From 16GB up to 256GB

- **Electrical/Physical Interface**
 - SATA Interface
 - ◆ Compliant with SATA Revision 3.2
 - ◆ Compatible with SATA 1.5Gbps, 3Gbps and 6Gbps interface
 - ◆ NCQ support up to queue depth = 32
 - ◆ Supports power management
 - ◆ Supports expanded register for SATA protocol 48 bit addressing mode

- **ECC Scheme**
 - Capable of correcting up to 120 bits per 2K Bytes of data

- **Supports SMART and TRIM commands**

- **Performance and Power Consumption**

| Capacity | Performance | | Power Consumption | |
|----------|-----------------|--------------|-------------------|------------|
| | CrystalDiskMark | | Read (mW) | Write (mW) |
| | Read (MB/s) | Write (MB/s) | | |
| 16GB | 145 | 140 | 1575 | 1850 |
| 32GB | 250 | 230 | 2000 | 2500 |
| 64GB | 330 | 310 | 2250 | 3000 |
| 128GB | 330 | 310 | 2500 | 3250 |
| 256GB | 330 | 310 | 3000 | 3750 |

NOTE:

For more details on Power Consumption, please refer to Chapter 4.2.

- **Endurance - TBW (Terabytes Written)**

| Capacity | TBW |
|----------|--------|
| 16GB | 912 |
| 32GB | 1,825 |
| 64GB | 3,650 |
| 128GB | 7,300 |
| 256GB | 14,600 |

NOTES:

1. Many factors affect drive endurance / TBW, including flash configuration, SDR configuration, host platform, usage model, write amplification factor, etc. The figures above are estimates and are not guarantees.

- **Part Numbers**

Industrial 2.5" SSD (-40 to 85°C Operating Temperature)

| Capacity | Part Number |
|----------|-------------------|
| 16GB | DE16TQJDN-35000-D |
| 32GB | DE32TQJDN-35000-D |
| 64GB | DE64TNKDN-35000-D |
| 128GB | DE1HTNJDN-35000-D |
| 256GB | DE2HTNJDN-35000-D |

3. ENVIRONMENTAL SPECIFICATIONS

3.1. Environmental Conditions

3.1.1. Temperature and Humidity

- Temperature:
 - ◆ Storage: -40°C to 85°C
 - ◆ Operational: -50°C to 100°C

- Humidity:
 - ◆ RH 95% under 55°C (operational)

3.1.2. Shock & Vibration

- Shock Specification
 - ◆ 1500G, 0.5ms duration, 3 axes

- Vibration Specification
 - ◆ 20Hz ~80Hz/1.52mm displacement, 80Hz~2000Hz / 20G Acceleration, 3 axes

3.1.3. Electrostatic Discharge (ESD)

- +/- 4KV

3.2. MTBF

MTBF, an acronym for Mean Time Between Failures, is a measure of a device's reliability. Its value represents the average time between a repair and the next failure. The measure is typically in units of hours. The higher the MTBF value, the higher the reliability of the device. The predicted result of Delkin's Industrial 2.5" SSD is more than 2,000,000 hours at 0 °C.

3.3. Certification & Compliance

- RoHS
- SATA III (SATA Rev. 3.2)
- Up to ATA/ATAPI-8 (Including S.M.A.R.T)

4. ELECTRICAL SPECIFICATIONS

4.1. Supply Voltage

Table 4-1 Supply Voltage

| Parameter | Rating |
|-------------------|----------------------|
| Operating Voltage | 5V \pm 5% (Option) |
| Maximum Ripple | 100mV, 0 ~ 30MHz |

4.2. Power Consumption

Table 4-2 Power Consumption

| Capacity | Read | Write | Idle |
|----------|------|-------|------|
| 16GB | 1575 | 1850 | 450 |
| 32GB | 2000 | 2500 | 450 |
| 64GB | 2250 | 3000 | 450 |
| 128GB | 2500 | 3250 | 450 |
| 256GB | 3000 | 3750 | 450 |

Unit: mW

NOTES:

1. The average value of power consumption is achieved based on 100% conversion efficiency.
2. The measured power voltage is 5V.
3. Power Consumption may differ according to flash configuration, SDR configuration, and host platform.

5. INTERFACE

5.1. Pin Assignment and Descriptions

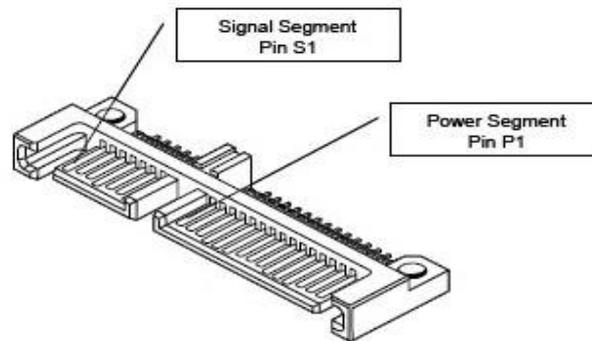

Table 5-1 Signal Segment Pin Assignment and Descriptions

| PIN NUMBER | FUNCTION |
|------------|---------------------------------|
| S1 | GND |
| S2 | A+ (DIFFERENTIAL SIGNAL PAIR A) |
| S3 | A- (DIFFERENTIAL SIGNAL PAIR A) |
| S4 | GND |
| S5 | B- (DIFFERENTIAL SIGNAL PAIR B) |
| S6 | B+ (DIFFERENTIAL SIGNAL PAIR B) |
| S7 | GND |

Table 0-2 Power Segment Pin Assignment and Descriptions

| PIN NUMBER | FUNCTION |
|------------|---------------------------|
| P1 | NOT USED (3.3V) |
| P2 | NOT USED (3.3V) |
| P3 | DEVSLP |
| P4 | GND |
| P5 | GND |
| P6 | GND |
| P7 | 5V PRE-CHARGE |
| P8 | 5V |
| P9 | 5V |
| P10 | GND |
| P11 | RESERVED |
| P12 | GND |
| P13 | NOT USED (12V PRE-CHARGE) |
| P14 | NOT USED (12V) |
| P15 | NOT USED (12V) |

6. SUPPORTED COMMANDS

6.1. ATA Command List

Table 6-1 ATA Command List

| Op Code | Description | Op Code | Description |
|---------|-----------------------------------|---------|---------------------------|
| 00h | NOP | 97h | IDLE |
| 06h | Data Set Management | 98h | CHECK POWER MODE |
| 10h-1Fh | Recalibrate | 99h | SLEEP |
| 20h | Read Sectors | B0h | SMART |
| 21h | Read Sectors without Retry | B1h | DEVICE CONFIGURATION |
| 24h | Read Sectors EXT | C4h | Read Multiple |
| 25h | Read DMA EXT | C5h | Write Multiple |
| 27h | Read Native Max Address EXT | C6h | Set Multiple Mode |
| 29h | Read Multiple EXT | C8h | Read DMA |
| 2Fh | Read Log EXT | C9h | Read DMA without Retry |
| 30h | Write Sectors | CAh | Write DMA |
| 31h | Write Sectors without Retry | CBh | Write DMA without Retry |
| 34h | Write Sectors EXT | CEh | Write Multiple FUA EXT |
| 35h | Write DMA EXT | E0h | Standby Immediate |
| 37h | Set Native Max Address EXT | E1h | Idle Immediate |
| 38h | CFA WRITE SECTORS WITHOUT ERASE | E2h | Standby |
| 39h | Write Multiple EXT | E3h | Idle |
| 3Dh | Write DMA FUA EXT | E4h | Read Buffer |
| 3Fh | Write Long EXT | E5h | Check Power Mode |
| 40h | Read Verify Sectors | E6h | Sleep |
| 41h | Read Verify Sectors without Retry | E7h | Flush Cache |
| 42h | Read Verify Sectors EXT | E8h | Write Buffer |
| 45h | WRITE UNCORRECTABLE EXT | EAh | Flush Cache EXT |
| 60h | Read FPDMA Queued | ECh | Identify Device |
| 61h | Write FPDMA Queued | EFh | Set Features |
| 70h-7Fh | Seek | F1h | Security Set Password |
| 90h | Execute Device Diagnostic | F2h | Security Unlock |
| 91h | Initialize Device Parameters | F3h | Security Erase Prepare |
| 92h | Download Microcode | F4h | Security Erase Unit |
| 93h | DOWNLOAD MICROCODE DMA | F5h | Security Freeze Lock |
| 94h | STANDBY IMMEDIATE | F6h | Security Disable Password |
| 95h | IDLE IMMEDIATE | F8h | Read Native Max Address |
| 96h | STANDBY | F9h | Set Max Address |

6.2. Identify Device Data

The following table details the sector data returned by the IDENTIFY DEVICE command.

Table 6-2 List of Device Identification

| Word | F: Fixed V: Variable X: Both | Default Value | Description |
|-------|------------------------------------|---------------|---|
| 0 | F | 0040h | General configuration bit-significant information |
| 1 | X | *1 | Obsolete – Number of logical cylinders |
| 2 | V | C837h | Specific configuration |
| 3 | X | 0010h | Obsolete – Number of logical heads (16) |
| 4-5 | X | 00000000h | Retired |
| 6 | X | 003Fh | Obsolete – Number of logical sectors per logical track (63) |
| 7-8 | V | 00000000h | Reserved for assignment by the Compact Flash Association |
| 9 | X | 0000h | Retired |
| 10-19 | F | Varies | Serial number (20 ASCII characters) |
| 20-21 | X | 0000h | Retired |
| 22 | X | 0000h | Obsolete |
| 23-26 | F | Varies | Firmware revision (8 ASCII characters) |
| 27-46 | F | Varies | Model number |
| 47 | F | 8010h | 7:0- Maximum number of sectors transferred per interrupt on MULTIPLE commands |
| 48 | F | 4000h | Trusted Computing feature set options(not support) |
| 49 | F | 2F00h | Capabilities |
| 50 | F | 4000h | Capabilities |
| 51-52 | X | 000000000h | Obsolete |
| 53 | F | 0007h | Words 88 and 70:64 valid |
| 54 | X | *1 | Obsolete – Number of logical cylinders |
| 55 | X | 0010h | Obsolete – Number of logical heads (16) |
| 56 | X | 003Fh | Obsolete – Number of logical sectors per track (63) |
| 57-58 | X | *2 | Obsolete – Current capacity in sectors |
| 59 | F | 0110h | Number of sectors transferred per interrupt on MULTIPLE commands |
| 60-61 | F | *3 | Maximum number of sector (28bit LBA mode) |
| 62 | X | 0000h | Obsolete |
| 63 | F | 0407h | Multi-word DMA modes supported/selected |
| 64 | F | 0003h | PIO modes supported |
| 65 | F | 0078h | Minimum Multiword DMA transfer cycle time per word |

| Word | F: Fixed V: Variable X: Both | Default Value | Description |
|---------|------------------------------------|-------------------|---|
| 66 | F | 0078h | Manufacturer's recommended Multiword DMA transfer cycle time |
| 67 | F | 0078h | Minimum PIO transfer cycle time without flow control |
| 68 | F | 0078h | Minimum PIO transfer cycle time with IORDY flow control |
| 69 | F | 0100h | Additional Supported (support download microcode DMA) |
| 70 | F | 0000h | Reserved |
| 71-74 | F | 0000000000000000h | Reserved for the IDENTIFY PACKET DEVICE command |
| 75 | F | 001Fh | Queue depth |
| 76 | F | 670eh | Serial SATA capabilities |
| 77 | F | 0084h | Serial ATA Additional Capabilities |
| 78 | F | 014Ch | Serial ATA features supported |
| 79 | V | 0040h | Serial ATA features enabled |
| 80 | F | 07F8h | Major Version Number |
| 81 | F | 0000h | Minor Version Number |
| 82 | F | 346bh | Command set supported |
| 83 | F | 7d09h | Command set supported |
| 84 | F | 6063h | Command set/feature supported extension |
| 85 | V | 3469h | Command set/feature enabled |
| 86 | V | bc01h | Command set/feature enabled |
| 87 | V | 6063h | Command set/feature default |
| 88 | V | 003Fh | Ultra DMA Modes |
| 89 | F | 0001h | Time required for security erase unit completion |
| 90 | F | 001Eh | Time required for Enhanced security erase completion |
| 91 | V | 0000h | Current advanced power management value |
| 92 | V | FFFEh | Master Password Revision Code |
| 93 | F | 0000h | Hardware reset result. The contents of the bits (12:0) of this word can be changed only during the execution of hardware reset. |
| 94 | V | 0000h | Vendor's recommended and actual acoustic management value |
| 95 | F | 0000h | Stream Minimum Request Size |
| 96 | V | 0000h | Streaming Transfer Time – DMA |
| 97 | V | 0000h | Streaming Access Latency – DMA and PIO |
| 98-99 | F | 0000h | Streaming Performance Granularity |
| 100-103 | V | *4 | Maximum user LBA for 48 bit Address feature set |

| Word | F: Fixed V: Variable X: Both | Default Value | Description |
|---------|------------------------------------|---|---|
| 104 | V | 0000h | Streaming Transfer Time – PIO |
| 105 | F | 0008h | Maximum number of 512-byte blocks per DATA SET MANAGEMENT command |
| 106 | F | 4000h | Physical sector size/Logical sector size |
| 107 | F | 0000h | Inter-seek delay for ISO-7779 acoustic testing in microseconds |
| 108-111 | F | 0000000000000000h | Unique ID |
| 112-115 | F | 0000000000000000h | Reserved |
| 116 | V | 0000h | Reserved |
| 117-118 | F | 00000000h | Words per logical Sector |
| 119 | F | 4014h | Supported settings |
| 120 | F | 4014h | Command set/Feature Enabled/Supported |
| 121-126 | F | 0h | Reserved |
| 127 | F | 0h | Removable Media Status Notification feature set support |
| 128 | V | 0021h | Security status |
| 129-140 | X | 0h | Vendor specific |
| 141 | X | 0001h | Vendor specific |
| 142-159 | X | 0h | Vendor specific |
| 160 | F | 0h | Compact Flash Association (CFA) power mode 1 |
| 161-167 | X | 0h | Reserved for assignment by the CFA |
| 168 | F | 3h 2.5" 4h 1.8" 5h Less than 1.8" | Device Nominal Form Factor |
| 169 | F | 0001h | DATA SET MANAGEMENT command is supported |
| 170-173 | F | 0h | Additional Product Identifier |
| 174-175 | | 0h | Reserve |
| 176-205 | V | 0h | Current media serial number |
| 206 | F | 0h | SCT Command Transport |
| 207-208 | F | 0h | Reserved |
| 209 | F | 4000h | Alignment of logical blocks within a physical block |
| 210-211 | V | 0000h | Write-Read-Verify Sector Count Mode 3 (not supported) |
| 212-213 | F | 0000h | Write-Read-Verify Sector Count Mode 2 (not supported) |
| 214-216 | | 0000h | NV Cache relate (not supported) |
| 217 | F | 0001h | Non-rotating media device |
| 218 | F | 0h | Reserved |

| Word | F: Fixed V: Variable X: Both | Default Value | Description |
|---------|------------------------------------|-------------------------|--|
| 219 | F | 0h | NV Cache relate (not supported) |
| 220 | V | 0h | Write read verify feature set current mode |
| 221 | | 0h | Reserved |
| 222 | F | 107Fh | Transport major version number |
| 223 | F | 0h | Transport minor version number |
| 224-229 | | 0h | reserved |
| 230-233 | | 0h | Extend number of user addressable sectors |
| 234 | | 0001h | Minimum number of 512-byte data blocks per DOWNLOAD MICROCODE command for mode 03h |
| 235 | | 0080h | Maximum number of 512-byte data blocks per DOWNLOAD MICROCODE command for mode 03h |
| 236-254 | F | 0h | Reserved |
| 255 | X | XXA5h XX is variable | Integrity word (Checksum and Signature) |

Table 6-3 List of Device Identification for Each Capacity

| Capacity (GB) | *1 (Word 1/Word 54) | *2 (Word 57 - 58) | *3 (Word 60 - 61) | *4 (Word 100 - 103) |
|------------------|------------------------|----------------------|----------------------|------------------------|
| 16 | | | | |
| 32 | | | | |
| 64 | 3FFFh | FBFC10h | 7740AB0h | 7740AB0h |
| 128 | 3FFFh | FBFC10h | EE7C2B0h | EE7C2B0h |
| 256 | 3FFFh | FBFC10h | FFFFFFFFh | 1DCF32B0h |

6.3. SMART

6.3.1. Command Description

6.3.1.1. I/O Registers

Communication to or from device through Data register and 7 Command Block registers (28bits command format), include Feature register, Error register, Sector Count register, Sector Number register, Cylinder Low register, Cylinder High register, Drive Head register, Status register, Command register.

Table 6-4 Command Block Registers Addressing

| Offset address | Read | Write | Value Type |
|----------------|-------------------------------------|-------------------------------------|------------|
| 0x00 | Data | Data | WORD |
| 0x01 | Error | Feature | BYTE |
| 0x02 | Sector Count | Sector Count | BYTE |
| 0x03 | Sector Number (LBA low current) | Sector Number (LBA low current) | BYTE |
| 0x04 | Cylinder Low (LBA Mid current) | Cylinder Low (LBA Mid current) | BYTE |
| 0x05 | Cylinder High (LBA High current) | Cylinder High (LBA High current) | BYTE |
| 0x06 | Drive Head | Drive Head | BYTE |
| 0x07 | Status | Command | BYTE |

Direction: Input means from Host to Device, Output means from Device to Host

6.3.1.2. SMART Command Table

| Vender Command | Feature | Sector Count | Sector Number | Cylinder Low | Cylinder High | Drive Head | Command |
|-----------------------------------|----------------|------------------------|----------------------|---------------------|----------------------|-------------------|----------------|
| Smart Read Attribute | 0xD0 | 0x01 | XX | 0x4F | 0xC2 | 0xA0 | 0xB0 |
| Smart Read Attribute Thresholds | 0xD1 | 0x01 | XX | 0x4F | 0xC2 | 0xA0 | 0xB0 |
| Smart Enable Attribute Auto Save | 0xD2 | 0xF1 | XX | 0x4F | 0xC2 | 0xA0 | 0xB0 |
| Smart Disable Attribute Auto Save | 0xD2 | 0x00 | XX | 0x4F | 0xC2 | 0xA0 | 0xB0 |
| SMART SAVE ATTRIBUTE VALUES | 0xD3 | XX | XX | 0x4F | 0xC2 | 0xA0 | 0xB0 |
| SMART EXECUTE OFF-LINE IMMEDIATE | 0xD4 | XX | XX | 0x4F | 0xC2 | 0xA0 | 0xB0 |
| SMART READ LOG | 0xD5 | Depends on Log Address | XX | 0x4F | 0xC2 | 0xA0 | 0xB0 |
| SMART WRITE LOG | 0xD6 | Depends on Log Address | XX | 0x4F | 0xC2 | 0xA0 | 0xB0 |
| Smart Enable Operations | 0xD8 | XX | XX | 0x4F | 0xC2 | 0xA0 | 0xB0 |
| Smart Disable Operation | 0xD9 | XX | XX | 0x4F | 0xC2 | 0xA0 | 0xB0 |
| Smart Return Status | 0xDA | XX | XX | 0x4F | 0xC2 | 0xA0 | 0xB0 |
| SMART ENABLE AUTOMATIC OFF-LINE | 0xDB | XX | XX | 0x4F | 0xC2 | 0xA0 | 0xB0 |
| SMART DISABLE AUTOMATIC OFF-LINE | 0xDB | XX | XX | 0x4F | 0xC2 | 0xA0 | 0xB0 |

6.3.1.3. SMART Read Attribute

[Protocol] PIO Data In

[Input]

| Register | 7 | 6 | 5 | 4 | 3 | 2 | 1 | 0 |
|-------------------------------------|------|---|---|---|---|---|---|---|
| Feature | 0xD0 | | | | | | | |
| Sector Count | 0x01 | | | | | | | |
| Sector Number (LBA LOW current) | N/A | | | | | | | |
| Cylinder Low (LBA MID current) | 0x4F | | | | | | | |
| Cylinder High (LBA HIGH current) | 0xC2 | | | | | | | |
| Drive Head | 1 | 0 | 1 | 0 | 0 | 0 | 0 | 0 |
| Command | 0xB0 | | | | | | | |

[Normal Output]

| Register | 7 | 6 | 5 | 4 | 3 | 2 | 1 | 0 |
|-------------------------------------|------|---|---|---|---|---|---|---|
| Error | N/A | | | | | | | |
| Sector Count | N/A | | | | | | | |
| Sector Number (LBA LOW current) | N/A | | | | | | | |
| Cylinder Low (LBA MID current) | N/A | | | | | | | |
| Cylinder High (LBA HIGH current) | N/A | | | | | | | |
| Drive Head | 0xE0 | | | | | | | |
| Status | 0x50 | | | | | | | |

[Description]

This command will return 1 sector of SMART Read Attribute information.

Attribute Table

| Attribute ID | Description |
|--------------|--|
| 01h | Number of accumulation of uncorrectable error. (Range 0~255) |
| 09h | Power on hours count. (Range 0-4294967295) |
| 0Ch | Drive power cycle count (Number of accumulation of power on/off cycles) |
| A8h | Sata PHY error count (since last power cycle) this value include all PHY error count, ex data FIS CRC code error, disparity error ,command FIS crc.....) |
| AAh | Bad block count. |
| ADh | Erase count |
| C0h | Number of unexpected power loss count |
| C2h | Temperature (See Note 1 for interpretation of temperature data) |
| DAh | Number of accumulation CRC error (read/write data FIS CRC error) |
| E7h | SSD life remaining |
| F1h | Lifetime write from host |

Smart attribute actual data

| 0 | 1 | 2 | 3 | 4 | 5 | 6 | 7 | 8 | 9 | 10 | 11 | |
|-----|------|------|------------------|-------------------|---------------------------------------|---|---------------------------------|---|---------------------------|----|----|-----------|
| ID | Flag | flag | value | worse | DATA | | | | | | | threshold |
| 01h | 0Bh | 00h | 64h | 64h | 0 | 0 | ECC error | 0 | 0 | 0 | 0 | 32h |
| 09h | 12h | 00h | 64h | 64h | power on hour | | 0 | 0 | 0 | 0 | 0 | 00h |
| 0Ch | 12h | 00h | 64h | 64h | power on/off cycles | | | | 0 | 0 | 0 | 00h |
| A8h | 12h | 00h | 64h | 64h | SATA PHY error count | | | | 0 | 0 | 0 | 00h |
| AAh | 03h | 00h | Note 2 | note 2 | early bad block NO | | 0 | 0 | later bad block NO | | 0 | 0ah |
| ADh | 12h | 00h | 64h | 64h | max erase count (MAX 65535) | | average erase count (MAX 65535) | | 0 | 0 | 0 | 00h |
| C0h | 12h | 00h | 64h | 64h | number of accidental power loss count | | | | 0 | 0 | 0 | 00h |
| C2h | 23h | 00h | 100-Current Temp | 100-Highest value | Current Temp (see Note 1) | | Lowest Temp (see Note 1) | | Highest Temp (see Note 1) | | 0 | 1Eh |
| DAh | 0Bh | 00h | 64h | 64h | number of CRC Error | | | | 0 | 0 | 0 | 32h |
| E7h | 13h | 00h | 64h | 64h | Note 3 | 0 | 0 | 0 | 0 | 0 | 0 | 00h |
| F1h | 32h | 00h | 0h | 0h | Host write 1GB count | | | | 0 | 0 | 0 | 0 |

Note 1: Raw data from the drive is a signed 8 bit integer, interpret as follows:
Value 0 – 127: Interpret directly as temperature data, 0 to 127 Degrees C
Value 128 – 255: Interpret by subtracting 256, to produce -128 to -1 Degrees C

Note 2: $(100*(A-B))/A$, Max = 100, Min = 1, where:
A: Maximum Acceptable Number of Bad Block (Plane)
B: Current Number of Maximum Bad Block (Plane)

Note 3: $100 - (\text{average erase count} / \text{MAX erase count}) * 100$, where MAX erase count = 60K for SLC, 3K for MLC

6.3.1.4. SMART Read Attribute Thresholds

[Protocol] PIO Data In

[Input]

| Register | 7 | 6 | 5 | 4 | 3 | 2 | 1 | 0 |
|-------------------------------------|------|---|---|---|---|---|---|---|
| Feature | 0xD1 | | | | | | | |
| Sector Count | 0x01 | | | | | | | |
| Sector Number (LBA LOW current) | N/A | | | | | | | |
| Cylinder Low (LBA MID current) | 0x4F | | | | | | | |
| Cylinder High (LBA HIGH current) | 0xC2 | | | | | | | |
| Drive Head | 1 | 0 | 1 | 0 | 0 | 0 | 0 | 0 |
| Command | 0xB0 | | | | | | | |

[Normal Output]

| Register | 7 | 6 | 5 | 4 | 3 | 2 | 1 | 0 |
|-------------------------------------|------|---|---|---|---|---|---|---|
| Error | N/A | | | | | | | |
| Sector Count | N/A | | | | | | | |
| Sector Number (LBA LOW current) | N/A | | | | | | | |
| Cylinder Low (LBA MID current) | N/A | | | | | | | |
| Cylinder High (LBA HIGH current) | N/A | | | | | | | |
| Drive Head | 0xE0 | | | | | | | |
| Status | 0x50 | | | | | | | |

[Description]

This command will return 1 sector of SMART Read Attribute Thresholds information.

6.3.1.5. SMART Enable Attribute Auto Save

[Protocol] PIO Non-data

[Input]

| Register | 7 | 6 | 5 | 4 | 3 | 2 | 1 | 0 |
|-------------------------------------|------|---|---|---|---|---|---|---|
| Feature | 0xD2 | | | | | | | |
| Sector Count | 0XF1 | | | | | | | |
| Sector Number (LBA LOW current) | N/A | | | | | | | |
| Cylinder Low (LBA MID current) | 0x4F | | | | | | | |
| Cylinder High (LBA HIGH current) | 0xC2 | | | | | | | |
| Drive Head | 1 | 0 | 1 | 0 | 0 | 0 | 0 | 0 |
| Command | 0xB0 | | | | | | | |

[Normal Output]

| Register | 7 | 6 | 5 | 4 | 3 | 2 | 1 | 0 |
|-------------------------------------|------|---|---|---|---|---|---|---|
| Error | N/A | | | | | | | |
| Sector Count | N/A | | | | | | | |
| Sector Number (LBA LOW current) | N/A | | | | | | | |
| Cylinder Low (LBA MID current) | N/A | | | | | | | |
| Cylinder High (LBA HIGH current) | N/A | | | | | | | |
| Drive Head | 0xE0 | | | | | | | |
| Status | 0x50 | | | | | | | |

[Description]

The SMART ENABLE ATTRIBUTE AUTOSAVE command enables the attribute autosave feature of the device. This command may either allow the device, after some vendor specified event, to save the device updated attributes to non-volatile memory or this command may cause the autosave feature to be disabled. The state of the attribute autosave feature, either enabled or disabled, shall be preserved by the device during all power and reset events. The COUNT field cleared to zero shall cause the device to disable the attribute autosave

feature. Disabling this feature does not preclude the device from saving SMART data to non-volatile memory during some other normal operation (e.g., during a power-on or power-off sequence or during an error recovery sequence).

The COUNT field set to F1h shall cause the device to enable the attribute autosave feature. If the COUNT field is not set to 00h or F1h, then the actions taken by a device are vendor specific. If the device receives a command while processing the autosave routine the device shall begin processing the command within 2 s.

6.3.1.6. SMART Disable Attribute Auto Save

[Protocol] PIO Non-data

[Input]

| Register | 7 | 6 | 5 | 4 | 3 | 2 | 1 | 0 |
|--|------|---|---|---|---|---|---|---|
| Feature | 0xD2 | | | | | | | |
| Sector Count | 0x00 | | | | | | | |
| Sector Number (LBA LOW current) | N/A | | | | | | | |
| Cylinder Low (LBA MID current) | 0x4F | | | | | | | |
| Cylinder High (LBA HIGH current) | 0xC2 | | | | | | | |
| Drive Head | 1 | 0 | 1 | 0 | 0 | 0 | 0 | 0 |
| Command | 0xB0 | | | | | | | |

[Normal Output]

| Register | 7 | 6 | 5 | 4 | 3 | 2 | 1 | 0 |
|-------------------------------------|------|---|---|---|---|---|---|---|
| Error | N/A | | | | | | | |
| Sector Count | N/A | | | | | | | |
| Sector Number (LBA LOW current) | N/A | | | | | | | |
| Cylinder Low (LBA MID current) | N/A | | | | | | | |
| Cylinder High (LBA HIGH current) | N/A | | | | | | | |
| Drive Head | 0xE0 | | | | | | | |
| Status | 0x50 | | | | | | | |

[Description]

The SMART DISABLE ATTRIBUTE AUTOSAVE command disables the attribute autosave feature of the device. This command may either allow the device, after some vendor specified event, to save the device updated attributes to non-volatile memory or this command may cause the autosave feature to be disabled. The state of the attribute autosave feature, either enabled or disabled, shall be preserved by the device during all power and reset events. The COUNT field cleared to zero shall cause the device to disable the attribute autosave feature. Disabling this feature does not preclude the device from saving SMART data to non-volatile memory during some other normal operation (e.g., during a power-on or power-off sequence or during an error recovery sequence).

The COUNT field set to F1h shall cause the device to enable the attribute autosave feature. If the COUNT field is not set to 00h or F1h, then the actions taken by a device are vendor specific.

If the device receives a command while processing the autosave routine the device shall begin processing the command within 2 s.

6.3.1.7. SMART Execute Off-Line Immediate

[Protocol] PIO Non-data

[Input]

| Register | 7 | 6 | 5 | 4 | 3 | 2 | 1 | 0 |
|-------------------------------------|------------|---|---|---|---|---|---|---|
| Feature | 0xD4 | | | | | | | |
| Sector Count | 0x00 | | | | | | | |
| Sector Number (LBA LOW current) | subcommand | | | | | | | |
| Cylinder Low (LBA MID current) | 0x4F | | | | | | | |
| Cylinder High (LBA HIGH current) | 0xC2 | | | | | | | |
| Drive Head | 1 | 0 | 1 | 0 | 0 | 0 | 0 | 0 |
| Command | 0xB0 | | | | | | | |

[Normal Output]

| Register | 7 | 6 | 5 | 4 | 3 | 2 | 1 | 0 |
|-------------------------------------|------|---|---|---|---|---|---|---|
| Error | N/A | | | | | | | |
| Sector Count | N/A | | | | | | | |
| Sector Number (LBA LOW current) | N/A | | | | | | | |
| Cylinder Low (LBA MID current) | N/A | | | | | | | |
| Cylinder High (LBA HIGH current) | N/A | | | | | | | |
| Drive Head | 0xE0 | | | | | | | |
| Status | 0x50 | | | | | | | |

[Description]

The SMART EXECUTE OFF-LINE IMMEDIATE command causes the device to initiate the optional set of activities that collect SMART data in an off-line mode and then preserve this data across power and reset events, or process a vendor specific self-diagnostic test routine in either captive or off-line mode.

| Value | Description of subcommand to be processed |
|---------------------|---|
| 00h | Execute SMART off-line routine in off-line mode |
| 01h | Execute SMART Short self-test routine in off-line mode |
| 02h | Execute SMART Extended self-test routine in off-line mode |
| 03h (not supported) | Execute SMART Conveyance self-test routine in off-line mode |
| 04h | Execute SMART Selective self-test routine in off-line mode |
| 05h-3Fh | Reserved |
| 40h-7Eh | Vendor specific |
| 7Fh | Abort off-line mode self-test routine |
| 80h | Reserved |
| 81h | Execute SMART Short self-test routine in captive mode |
| 82h | Execute SMART Extended self-test routine in captive mode |
| 83h (not supported) | Execute SMART Conveyance self-test routine in captive mode |
| 84h | Execute SMART Selective self-test routine in captive mode |
| 85h-8Fh | Reserved |
| 90h-FFh | Vendor specific |

6.3.1.8. SMART Read Log

[Protocol] PO Data-In

[Input]

| Register | 7 | 6 | 5 | 4 | 3 | 2 | 1 | 0 |
|-------------------------------------|-----------------------|---|---|---|---|---|---|---|
| Feature | 0xD5 | | | | | | | |
| Sector Count | Depend on Log Address | | | | | | | |
| Sector Number (LBA LOW current) | Log Address | | | | | | | |
| Cylinder Low (LBA MID current) | 0x4F | | | | | | | |
| Cylinder High (LBA HIGH current) | 0xC2 | | | | | | | |
| Drive Head | 1 | 0 | 1 | 0 | 0 | 0 | 0 | 0 |
| Command | 0xB0 | | | | | | | |

[Normal Output]

| Register | 7 | 6 | 5 | 4 | 3 | 2 | 1 | 0 |
|-------------------------------------|------|---|---|---|---|---|---|---|
| Error | N/A | | | | | | | |
| Sector Count | N/A | | | | | | | |
| Sector Number (LBA LOW current) | N/A | | | | | | | |
| Cylinder Low (LBA MID current) | N/A | | | | | | | |
| Cylinder High (LBA HIGH current) | N/A | | | | | | | |
| Drive Head | 0xE0 | | | | | | | |
| Status | 0x50 | | | | | | | |

[Description]

The SMART READ LOG command returns the specified log to the host.

6.3.1.9. SMART Write Log

[Protocol] PO Data-Out

[Input]

| Register | 7 | 6 | 5 | 4 | 3 | 2 | 1 | 0 |
|-------------------------------------|-----------------------|---|---|---|---|---|---|---|
| Feature | 0xD6 | | | | | | | |
| Sector Count | Depend on Log Address | | | | | | | |
| Sector Number (LBA LOW current) | Log Address | | | | | | | |
| Cylinder Low (LBA MID current) | 0x4F | | | | | | | |
| Cylinder High (LBA HIGH current) | 0xC2 | | | | | | | |
| Drive Head | 1 | 0 | 1 | 0 | 0 | 0 | 0 | 0 |
| Command | 0xB0 | | | | | | | |

[Normal Output]

| Register | 7 | 6 | 5 | 4 | 3 | 2 | 1 | 0 |
|-------------------------------------|------|---|---|---|---|---|---|---|
| Error | N/A | | | | | | | |
| Sector Count | N/A | | | | | | | |
| Sector Number (LBA LOW current) | N/A | | | | | | | |
| Cylinder Low (LBA MID current) | N/A | | | | | | | |
| Cylinder High (LBA HIGH current) | N/A | | | | | | | |
| Drive Head | 0xE0 | | | | | | | |
| Status | 0x50 | | | | | | | |

[Description]

The SMART WRITE LOG command returns the specified log to the host.

6.3.1.10. SMART Enable Operations

[Protocol] PIO Non-data

[Input]

| Register | 7 | 6 | 5 | 4 | 3 | 2 | 1 | 0 |
|-------------------------------------|------|---|---|---|---|---|---|---|
| Feature | 0xD8 | | | | | | | |
| Sector Count | N/A | | | | | | | |
| Sector Number (LBA LOW current) | N/A | | | | | | | |
| Cylinder Low (LBA MID current) | 0x4F | | | | | | | |
| Cylinder High (LBA HIGH current) | 0xC2 | | | | | | | |
| Drive Head | 1 | 0 | 1 | 0 | 0 | 0 | 0 | 0 |
| Command | 0xB0 | | | | | | | |

[Normal Output]

| Register | 7 | 6 | 5 | 4 | 3 | 2 | 1 | 0 |
|-------------------------------------|------|---|---|---|---|---|---|---|
| Error | N/A | | | | | | | |
| Sector Count | N/A | | | | | | | |
| Sector Number (LBA LOW current) | N/A | | | | | | | |
| Cylinder Low (LBA MID current) | N/A | | | | | | | |
| Cylinder High (LBA HIGH current) | N/A | | | | | | | |
| Drive Head | 0xE0 | | | | | | | |
| Status | 0x50 | | | | | | | |

[Description]

The SMART ENABLE OPERATIONS command enables access to all available SMART capabilities within the device. The state of SMART, either enabled or disabled, shall be preserved by the device during all power and reset events. Once enabled, the receipt of subsequent SMART ENABLE OPERATIONS commands shall not affect any SMART data or functions.

6.3.1.11. SMART Disable Operations

[Protocol] PIO Non-data

[Input]

| Register | 7 | 6 | 5 | 4 | 3 | 2 | 1 | 0 |
|-------------------------------------|------|---|---|---|---|---|---|---|
| Feature | 0xD9 | | | | | | | |
| Sector Count | N/A | | | | | | | |
| Sector Number (LBA LOW current) | N/A | | | | | | | |
| Cylinder Low (LBA MID current) | 0x4F | | | | | | | |
| Cylinder High (LBA HIGH current) | 0xC2 | | | | | | | |
| Drive Head | 1 | 0 | 1 | 0 | 0 | 0 | 0 | 0 |
| Command | 0xB0 | | | | | | | |

[Normal Output]

| Register | 7 | 6 | 5 | 4 | 3 | 2 | 1 | 0 |
|-------------------------------------|------|---|---|---|---|---|---|---|
| Error | N/A | | | | | | | |
| Sector Count | N/A | | | | | | | |
| Sector Number (LBA LOW current) | N/A | | | | | | | |
| Cylinder Low (LBA MID current) | N/A | | | | | | | |
| Cylinder High (LBA HIGH current) | N/A | | | | | | | |
| Drive Head | 0xE0 | | | | | | | |
| Status | 0x50 | | | | | | | |

[Description]

The SMART DISABLE OPERATIONS command shall disable all SMART operations. After completion of this command without error the device shall report command aborted for all other SMART commands (e.g., SMART DISABLE OPERATIONS commands), except for the SMART ENABLE OPERATIONS command and the SCT Command Transport commands, which shall be processed as defined. The state of SMART (i.e., enabled or disabled) shall be preserved by the device during all power-on reset events.

6.3.1.12. SMART Return Status

[Protocol] PIO Non-data

[Input]

| Register | 7 | 6 | 5 | 4 | 3 | 2 | 1 | 0 |
|-------------------------------------|------|---|---|---|---|---|---|---|
| Feature | 0xDA | | | | | | | |
| Sector Count | N/A | | | | | | | |
| Sector Number (LBA LOW current) | N/A | | | | | | | |
| Cylinder Low (LBA MID current) | 0x4F | | | | | | | |
| Cylinder High (LBA HIGH current) | 0xC2 | | | | | | | |
| Drive Head | 1 | 0 | 1 | 0 | 0 | 0 | 0 | 0 |
| Command | 0xB0 | | | | | | | |

[Normal Output]

| Register | 7 | 6 | 5 | 4 | 3 | 2 | 1 | 0 |
|-------------------------------------|------|---|---|---|---|---|---|---|
| Error | N/A | | | | | | | |
| Sector Count | N/A | | | | | | | |
| Sector Number (LBA LOW current) | N/A | | | | | | | |
| Cylinder Low (LBA MID current) | N/A | | | | | | | |
| Cylinder High (LBA HIGH current) | N/A | | | | | | | |
| Drive Head | 0xE0 | | | | | | | |
| Status | 0x50 | | | | | | | |

[Description]

The SMART RETURN STATUS command causes the device to communicate the reliability status of the device to the host.

Status Return:

If Current Reserved Block > 3, return 0x4F, 0xC2

If Current Reserved Block <= 3, detected a threshold exceeded condition, return 0xF4, 0x2C

7. PHYSICAL DIMENSIONS

| Dimension | Measurement |
|-----------|------------------------------|
| Height | 9.20 mm ±0.15 (0.36") |
| Width | 69.75 mm +0.25/-0.15 (2.75") |
| Length | 99.70 mm ±0.25 (3.93") |

