

SURFBOARDS[®]

THE BREADBOARDING MEDIUM FOR **SURFACE MOUNT**™



33000 SERIES APPLICATION SPECIFIC ADAPTERS

IDS33405

REV A-10-2011

MODEL **33405**

5 LEAD .5 mm PITCH DEVICES

DEVICE LEAD WIDTH 1.5 To Max 3.0 MM

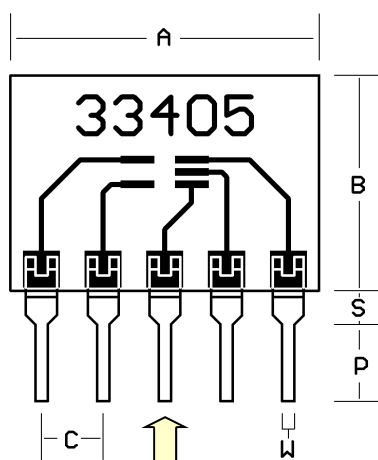

DRAWINGS
NOT TO
SCALE

**SINGLE-IN-LINE (SIP) PINS
ON .100 in. CENTERS**

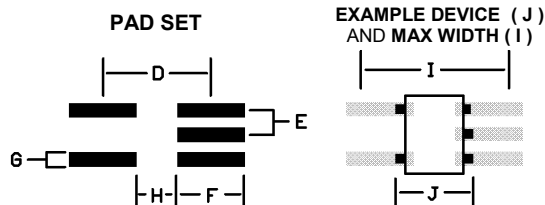

MOUNTING PADS ARE OVERSIZED IN LENGTH TO ACCEPT A WIDER RANGE OF DEVICE WIDTHS AND TOLERANCES AND TO PERMIT HAND SOLDERING.

[SEE WEBSITE FOR SOLDERING SUGGESTIONS](#)

BOARD SPECIFICATIONS

BOARD MATERIAL: .8mm, $\pm .13$ mm .031in $\pm .005$ in. Thick G-10 FR-4 Glass Epoxy or equivalent.

CIRCUITS: 1 oz. Copper with RoHS compliant Lead Free solder coating. Patten Position on board $\pm .5$ mm .020in.



ACCEPTS **SOT-553 SOT-665**

PARTIAL LISTING

- KEC **TE5V**
- PANASONIC **SSMini5-F2, SSMini5-F3
SSMini5-DA**
- RENESAS **5 Pin XSOF, P-USON-5
VSON-5**
- ROHM **EMD5, EMT5**
- TEXAS INST. **DRL (R-PDSO-N5)**
- TOSHIBA **E5V**

ALWAYS CONSULT DEVICE DATA SHEET TO INSURE PROPER FIT

Feature Pins on .1 in. Centers designed for use with Solderless breadboards, Conventional Breadboards, and Sockets with standard .1 in. centers. Use For Prototyping, Device Test or Evaluation and SMD to Through Hole Conversion.

FIG.	MM	IN.	NOTE:
A	12.7	.500	BOARD WIDTH $\pm .5$ mm .020in.
B	8.89	.350	BOARD HEIGHT $\pm .5$ mm .020in.
C	2.54	.100	SIP PIN SPACE $\pm .20$ mm .008in.
D	2.2	.086	PAD CENTERLINE
E	.5	.020	DEVICE LEAD PITCH
F	1.4	.055	PAD LENGTH
G	.3	.012	PAD WIDTH
H	.8	.031	GAP
I	3.0	.118	MAX LEAD WIDTH
J	1.5	.059	TYPICAL LEAD WIDTH
P	3.3	.130	LENGTH FROM SHOULDER $\pm .5$ mm .020in.
S	1.57	.062	PIN SHOULDER HEGHT
W	.5	.020	PIN WIDTH

TOLERANCES: If not noted are $\pm 20\%$. Nominal values are given. Controlling unit is Millimeters. Slight Variations due to manufacturing process can occur.

Copyright 2011 by Capital Advanced Technologies, Inc. All rights reserved. Surfboards is a registered trademark of Capital Advanced Technologies, Inc. The Breadboarding medium for surface mount, and the Leaf Circuit Logo are trademarks of Capital Advanced Technologies, Inc. All other trademarks are the property of their respective owners. Specifications, availability, and price is subject to change without notice. All information given is believed to be accurate but is not guaranteed. The user of information given or products represented by such information is responsible for determining the suitability of said information or products for a given purpose. No inducement is intended or permission granted for infringement of any patent or unauthorized use of any intellectual property of Capital Advanced Technologies or others.

CAPITAL ADVANCED TECHNOLOGIES, INC.

CAROL STREAM, ILLINOIS. USA PHONE 630-690-1696 FAX 630-690-2498

WWW.CapitalAdvanced.Com

MADE
IN
USA