

CR3000 HMI Module: HSPA+ Cellular

Red Lion Automation Series



▶▶▶ High-Speed HSPA+ Cellular Communication

The HSPA+ plug-in module expands the communication reach of our CR3000 HMI operator interface panels by providing a high-speed cellular connection to remote assets.

The module uses an HSPA+ cellular network to provide reliable high-speed data communication to remotely-located assets across oil and gas, water and wastewater, power, utility and alternative energy applications. Configure the HSPA+ module using Red Lion's Crimson® software, which makes setup simple via an intuitive graphical user interface with drag-and-drop functionality.



APPLICATIONS

- > Automotive
- > Food & Beverage
- > Factory Automation
- > OEM Machine Builders
- > Water/Wastewater

PRODUCT HIGHLIGHTS

- > Remotely monitor and control assets
- > High-speed cellular data connection
- > Removes need for external gateways
- > All-in-one solution, easily programmed

FEATURES & BENEFITS

- > Remote monitoring and control
 - Reliable high-speed cellular communication to monitor remote equipment and processes
 - Leverage powerful CR3000 HMI functionality through virtual HMI
 - Receive real-time email or SMS notifications
- > All-in-one solution
 - Removes need for external devices and communication gateways
 - Cost-effectively saves space and time
- > -10 to 50 °C operating temperature
 - Reliably works in industrial environments
- > Powered from CR3000 HMI host
 - Simplifies deployment by eliminating external power
- > Easily Programmed
 - Seamless configuration using Red Lion's Crimson desktop software

▶▶▶ HSPA+ Cellular Module Specifications

POWER

CMCMOD Power Consumption:
HSPA+ Mode: 3.5 W avg. (5.4 W max)
GPRS Mode: 8.5 W avg. (15 W max)

COMMUNICATION PROPERTIES

HSPA+ with Fallback Capability to 3G and 2G
Maximum Speeds: downlink 21 Mbps, upload 5.76 Mbps
Antenna Isolation from CR3000 HMI host device 500 VDC for 1 minute

ANTENNA CONNECTOR

One (1) SMA Female Connector on module
Requires 50 Ohm antenna with SMA male connector
Penta-band HSPA+ antenna (850/900/1700/1900/2100 MHz) global
Dual-band antenna (850/1900 MHz) US and Canada
Dual-band antenna (900/2100 MHz) Europe

CERTIFICATIONS AND COMPLIANCES

CE Approved:
EN 61326-1 to Industrial Locations
IEC/EN 61010-1
RoHS Compliant

ENVIRONMENTAL

Operating Temperature Range: -10 to 50 °C
Storage Temperature Range: -40 to 85 °C
Operating and Storage Humidity: 85% max relative humidity, non-condensing
Altitude: Up to 2000 meters

ORDERING GUIDE

PART NUMBER	DESCRIPTION
CRM000CMCMOD0000	CR3000 HMI Module, HSPA+ Cellular Module
ANT-TG090113	2G/3G 3" Hinged Antenna
ANT-G30B108111	2G/3G/4G LTE Low Profile Direct Permanent Mount Antenna, IP67 Rated
ANT-GA107201111	2G/3G 4.5" Whip Magnetic Mount Antenna, IP65 Rated
ANT-G21B301111	2G/3G Low Profile Direct Permanent Mount Antenna, IP65 Rated

DIMENSIONS In inches (mm)

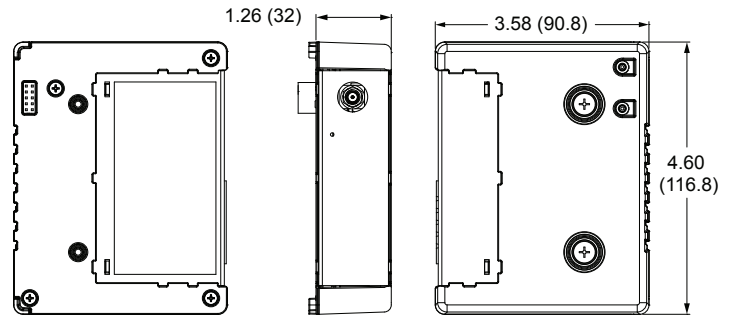

www.redlion.net

Connect. Monitor. Control.

Americas
sales@redlion.net

Asia-Pacific
asia@redlion.net

Europe
Middle East
Africa
europe@redlion.net

+1 (717) 767-6511

As the global experts in communication, monitoring and control for industrial automation and networking, Red Lion has been delivering innovative solutions for over forty years. Our automation, Ethernet and cellular M2M technology enables companies worldwide to gain real-time data visibility that drives productivity. Product brands include Red Lion, N-Tron and Sixnet. With headquarters in York, Pennsylvania, the company has offices across the Americas, Asia-Pacific and Europe. Red Lion is part of Spectris plc, the productivity-enhancing instrumentation and controls company. For more information, please visit www.redlion.net.

ADLD0483 061918 ©2018 Red Lion Controls, Inc. All rights reserved. Red Lion, the Red Lion logo, N-Tron and Sixnet are registered trademarks of Red Lion Controls, Inc. All other company and product names are trademarks of their respective owners.