

DO NOT SCALE DRAWING

REVISION

A INITIAL DRAWING 5.12.17 DW

PART NUMBER	A	B	C	D	E	RECESS
3.0 6 KRST30 Z100	3.0	1.66	6.0	2.05	5.5	POZI No 1
3.0 8 KRST30 Z100			8.0			
3.0 10 KRST30 Z100			10.0			
3.0 12 KRST30 Z100			12.0			
3.0 16 KRST30 Z100			16.0			
3.0 20 KRST30 Z100			20.0			
3.0 25 KRST30 Z100			25.0			
3.5 8 KRST30 Z100	3.5	1.91	8.0	2.8	7.3	POZI No 2
3.5 10 KRST30 Z100			10.0			
3.5 12 KRST30 Z100			12.0			
3.5 16 KRST30 Z100			16.0			
3.5 25 KRST30 Z100			25.0			
4.0 10 KRST30 Z100	4.0	2.17	10.0	2.5	8.0	POZI No 2
4.0 12 KRST30 Z100			12.0			
4.0 16 KRST30 Z100			16.0			
4.0 20 KRST30 Z100			20.0			
4.0 25 KRST30 Z100			25.0			
4.0 30 KRST30 Z100			30.0			
5.0 12 KRST30 Z100	5.0	2.68	12.0	3.4	9.3	POZI No 2
5.0 14 KRST30 Z100			14.0			
5.0 16 KRST30 Z100			16.0			
5.0 18 KRST30 Z100			18.0			
5.0 20 KRST30 Z100			20.0			
5.0 25 KRST30 Z100			25.0			
5.0 30 KRST30 Z100			30.0			

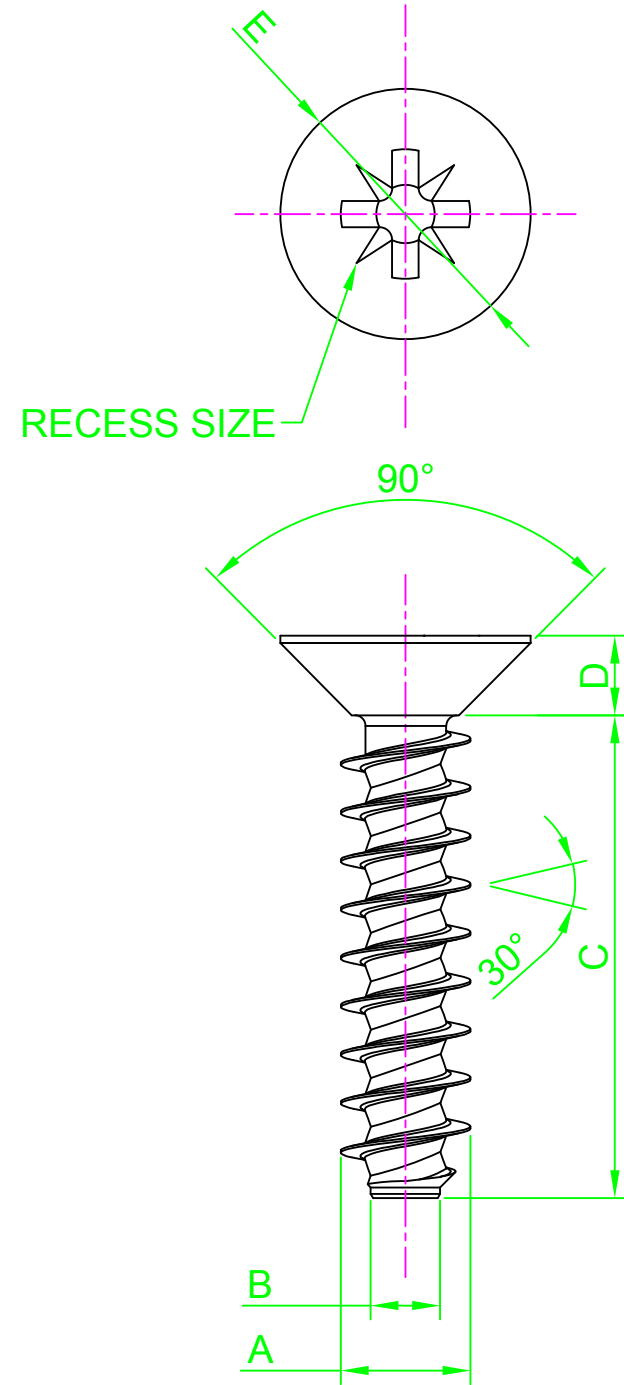

NOTES:



UNLESS OTHERWISE SPECIFIED:
DIMENSIONS ARE IN MM (MILLIMETERS).
SURFACE FINISH:
TOLERANCES:

MATERIAL:
STEEL

TITLE:
POZI CSK HEAD POLYMATE 30
SCREW FOR PLASTIC

	NAME	DATE
DRAWN	Darryl Wilson	05.12.2017
CHK'D		
APPVD		

HEAT TREATMENT:
CASE HARDENED

DESIGN RIGHT. TR FASTENINGS LTD, 2003
UNDER NO CIRCUMSTANCES MUST THIS
DRAWING BE COPIED OR DISCLOSED
WITHOUT FIRST OBTAINING WRITTEN
AUTHORITY.

CUSTOMER PART NUMBER:

FINISH:
TC1D - COMMERCIAL ZINC/CLEAR

DRAWING NUMBER:
TR32KRST30

A4

PROJECTION

