

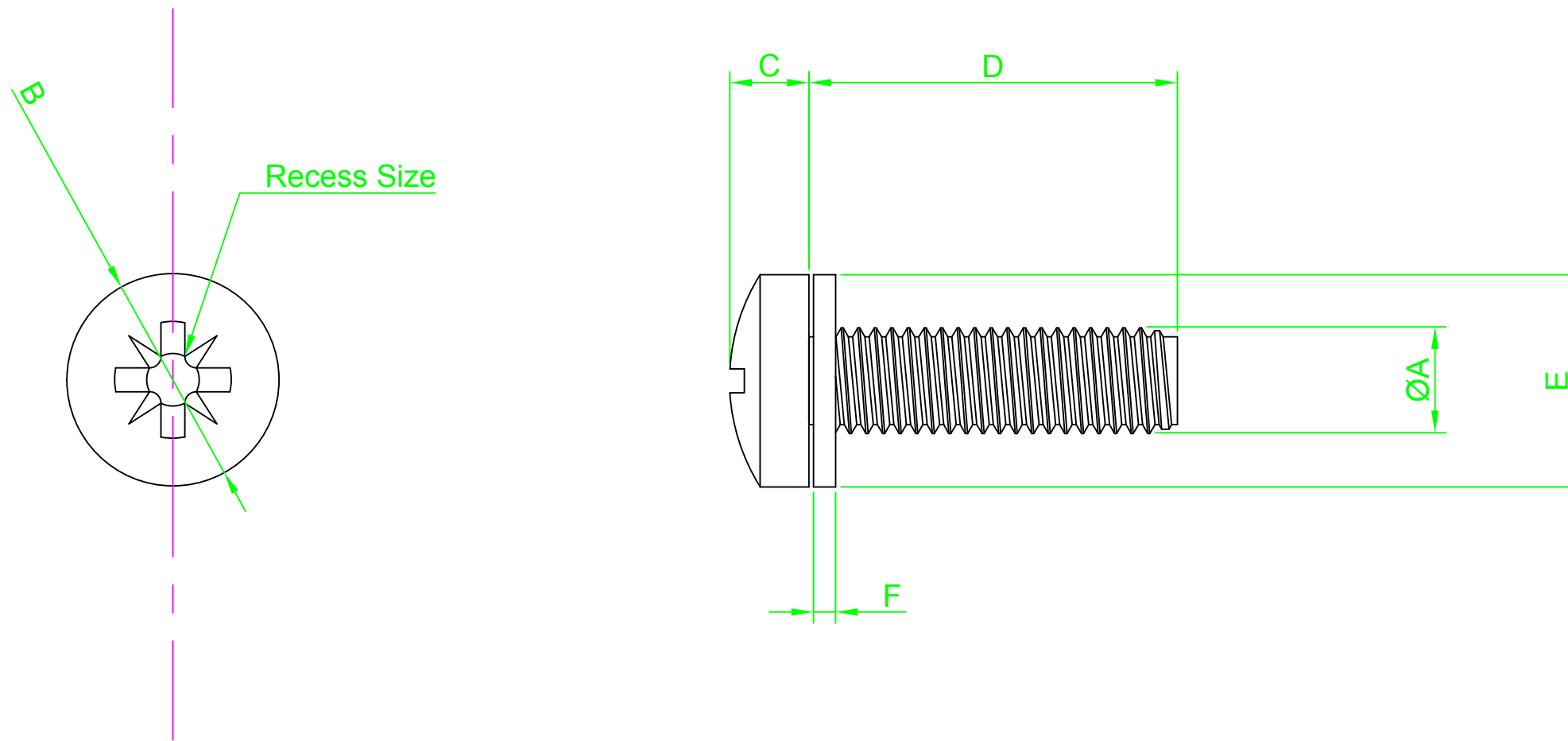

DO NOT SCALE DRAWING



REVISION	
A	INITIAL DRAWING 26.01.16 DW

Part Number	ØA	B Nom	C Nom	Recess Size	D Length	E Max	F Nom
M3 12 PRSTSY Z100	M3-0.5	6.0	2.4	Pozi #1	12.0	7.0	0.6

NOTES:



Fastenings

DESIGN RIGHT. TR FASTENINGS LTD, 2003
 UNDER NO CIRCUMSTANCES MUST THIS
 DRAWING BE COPIED OR DISCLOSED
 WITHOUT FIRST OBTAINING WRITTEN
 AUTHORITY.

UNLESS OTHERWISE SPECIFIED:
 DIMENSIONS ARE IN MM (MILLIMETERS).
 SURFACE FINISH:
 TOLERANCES: DIN 7985 / DIN 6902A

NAME	DATE
DRAWN Darryl Wilson	26.01.16
CHK'D	
APPVD	

CUSTOMER PART NUMBER:
 N/A

MATERIAL:
 Steel

HEAT TREATMENT:

FINISH:
 TC1 - Commercial Zinc/Clear Trivalent

TITLE:
 Pozi Pan Head Machine Screw c/w Plain
 Washer Sems DIN 7985 / DIN 6902A

DRAWING NUMBER:
 TR32PRSTSYZ100

A4