

LOC	DIST	P	F	ZONE	LTR	DESCRIPTION	DATE	APPD
GP	00				K	REVISED PER EC 0513-0234-05	09NOV05	JG

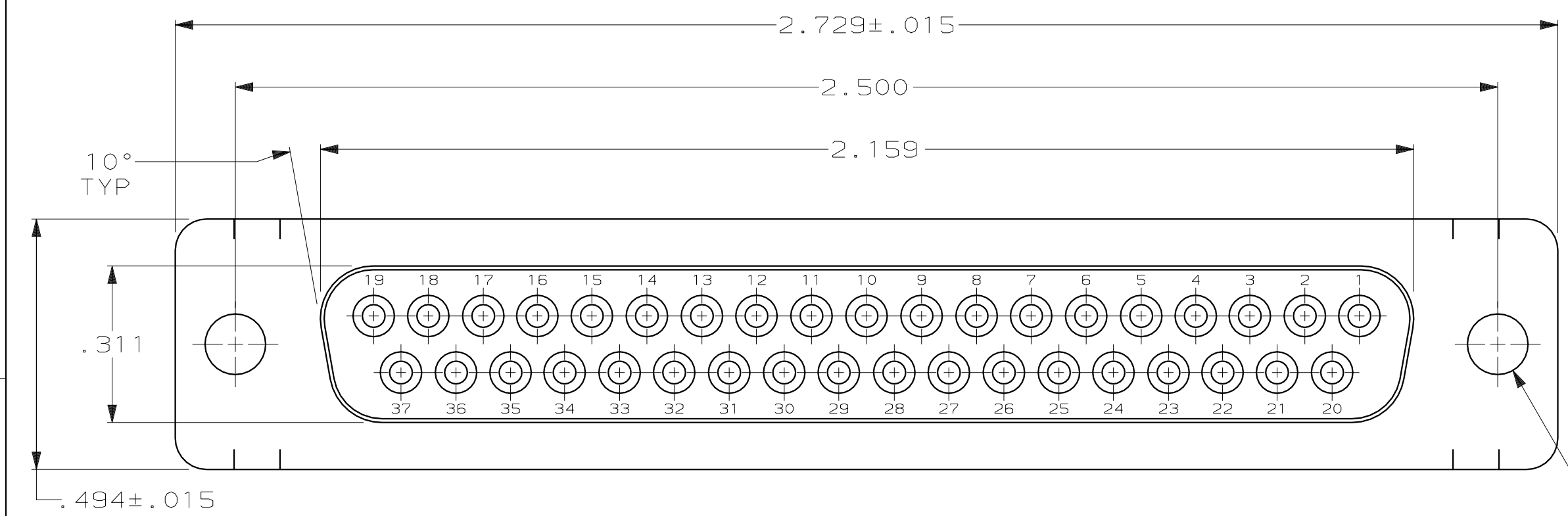

A DIA
2 HOLES

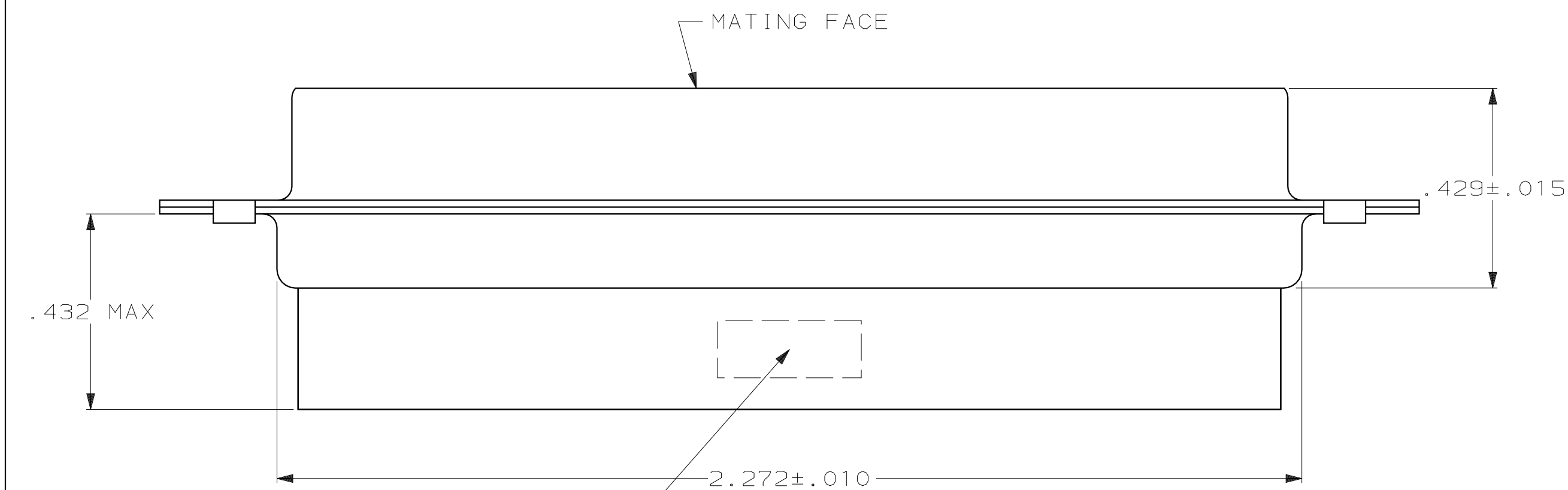

"AMP", PART NO. & DATE CODE, MARKED IN AREA INDICATED, ON FAR SIDE

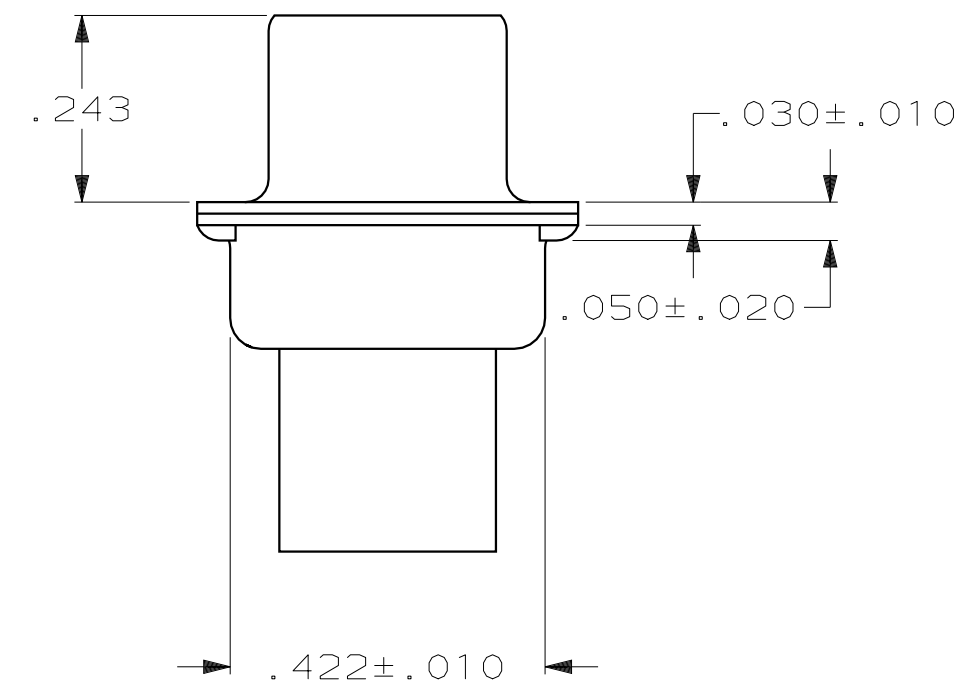

SUPERSEDED BY 205209-1
OBSOLETE

PACKAGING TYPE	SHELL FINISH	A	PART NO
STANDARD	△8	.120	205209-7
SMALL PACK	△5	.120	205209-6
STANDARD	△6	.154	205209-3
STANDARD	△7	.120	205209-2
STANDARD	△5	.120	205209-1

- CONNECTOR ACCEPTS SIZE 20 DF SOCKET CONTACTS, RETENTION TINES ARE AN INTEGRAL PART OF INSERT.
- CONNECTOR COMPLIES WITH 108-40005 WHERE APPLICABLE.
- NYLON, FLAME RETARDANT, 94V-0 RATED, GLASS FILLED, BLACK.
- STEEL PER ASTM A109.
- ZINC PLATED PER ASTM B633; TYPE II; CLASS SC1; YELLOW CHROMATE.
- TIN OR TIN-LEAD PLATED PER MIL-T-10727.
- TIN PLATED PER MIL-T-10727 OVER COPPER PER MIL-C-14550.
- ZINC PLATED .000200-.000400 THICK, YELLOW TRIVALENT CHROMIUM CHROMATE COATING.

DO NOT SCALE PRINT. UNLESS SPECIFIED DIMENSIONS IN INCHES TOLERANCES ON : 2 PLC DEC ± - 3 PLC DEC ± .005 ANGLES ± 2°	DR 7-19-85 S.WELDON CHK 7-29-85 J.GERACE APPD 7-29-85 L.BREKOSKY APPD 7-31-85 V.KUMAR	AMP AMP Incorporated Harrisburg, PA 17105-3608	
MATERIAL MOLDED PARTS: △3 SHELLS: △4	PRODUCT SPEC -	NAME RECEPTACLE CONNECTOR, SIZE 4, 37 POSITION, AMPLIMITE™ HDP	
FINISH SHELLS: SEE TABLE	APPLICATION SPEC -	SIZE C	CAGE CODE 00779
	WEIGHT -	DRAWING NO C=205209	SHEET 1 OF 1

THIS DRAWING IS A CONTROLLED DOCUMENT FOR AMP INCORPORATED. IT IS SUBJECT TO CHANGE AND THE CONTROLLING ENGINEERING ORGANIZATION SHOULD BE CONTACTED FOR THE LATEST REVISION.