

THIS DRAWING IS UNPUBLISHED. RELEASED FOR PUBLICATION
 © COPYRIGHT BY TYCO ELECTRONICS CORPORATION. ALL RIGHTS RESERVED.

LOC	DIST	REVISIONS					
BD	0	P	LTR	DESCRIPTION	DATE	DWN	APVD
			K1	REVISED PER ECO-06-3414	2/22/06	SS	SH

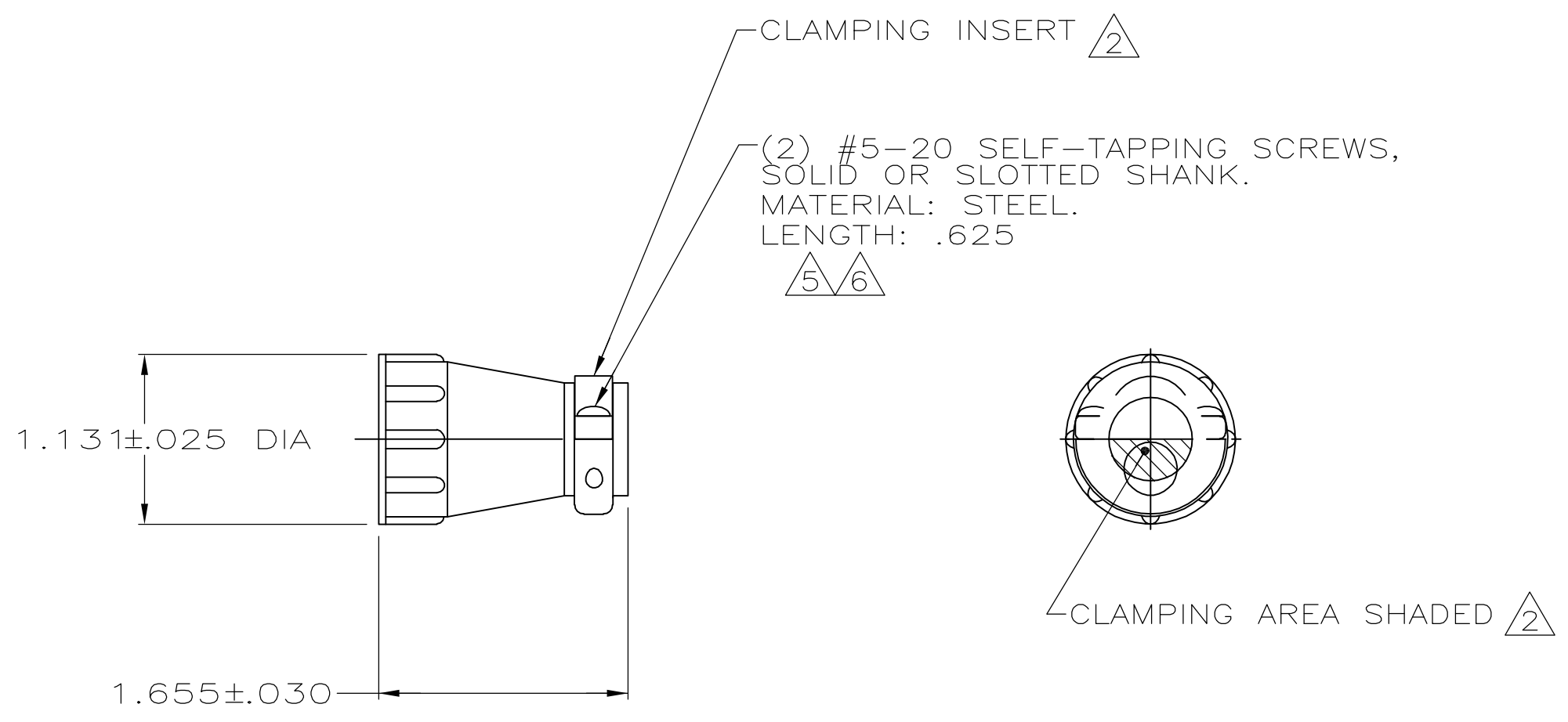

- 1. PARTS PACKAGED UNASSEMBLED.
- $\triangle 2$ CABLE CLAMPING AREA ADJUSTABLE FROM .100 TO .410 SQ IN BY REVERSING CLAMPING INSERTS.
- 3. .703 MAXIMUM CABLE OUTSIDE DIAMETER.
- $\triangle 4$ BULK PACKAGED KITS TO BE ORDERED IN MULTIPLES OF 100 ONLY.
- $\triangle 5$ FINISH: ZINC HEXAVALENT CHROMATE.
- $\triangle 6$ FINISH: ZINC NON-HEXAVALENT CHROMATE.

$\triangle 6$	$\triangle 4$	BULK	207008-6
$\triangle 6$		INDIVIDUAL	207008-5
$\triangle 5$	$\triangle 4$	BULK	207008-2
$\triangle 5$		INDIVIDUAL	207008-1
		PACKAGING	PART NUMBER

THIS DRAWING IS A CONTROLLED DOCUMENT.		DWN A GRAFF 4/23/91	Tyco Electronics Corporation Harrisburg, PA 17105-3608													
DIMENSIONS: INCHES		CHK W.G.LENKER 7-23-92	NAME CABLE CLAMP KIT, LARGE, SHELL SIZE 13, CPC													
TOLERANCES UNLESS OTHERWISE SPECIFIED:		APVD -	PRODUCT SPEC 108-10024													
<table border="0"> <tr><td>0 PLC</td><td>± -</td></tr> <tr><td>1 PLC</td><td>± -</td></tr> <tr><td>2 PLC</td><td>± -</td></tr> <tr><td>3 PLC</td><td>± -</td></tr> <tr><td>4 PLC</td><td>± -</td></tr> <tr><td>ANGLES</td><td>± -</td></tr> </table>		0 PLC	± -	1 PLC	± -	2 PLC	± -	3 PLC	± -	4 PLC	± -	ANGLES	± -	APPLICATION SPEC -	SIZE A3	CAGE CODE 00779
0 PLC	± -															
1 PLC	± -															
2 PLC	± -															
3 PLC	± -															
4 PLC	± -															
ANGLES	± -															
MATERIAL THERMOPLASTIC,	FINISH -	WEIGHT -	DRAWING NO C=207008	RESTRICTED TO -												
CUSTOMER DRAWING			SCALE 1:1	SHEET 1 OF 1												
			REV K1													