

Connector - SACC-P12MS-5CT-CM SH - 1021815

Please be informed that the data shown in this PDF Document is generated from our Online Catalog. Please find the complete data in the user's documentation. Our General Terms of Use for Downloads are valid (<http://phoenixcontact.com/download>)



Connector, Universal, 5-position, shielded, Plug straight M12 Push-Pull, A-coded, Crimp connection, knurl material: PA 6.6, external cable diameter 4.5 mm ... 7.5 mm, without crimp contacts

Why buy this product

- ✓ Plug and Produce: convenient and secure connection, thanks to the manufacturer-independent locking system
- ✓ Extremely compact, thanks to the small wiring space and high contact density
- ✓ Clear feedback: the connector springs back when not snapped into place correctly
- ✓ Safely shielded: reliable shield connection even under extreme mechanical strain
- ✓ Robust connection: suitable for railway applications with high shock and vibration loads
- ✓ Automated processing possible

Key Commercial Data

Packing unit	1 STK
GTIN	 4 055626 514642
GTIN	4055626514642
Weight per Piece (excluding packing)	29.800 g
Custom tariff number	85366990
Country of origin	Germany

Technical data

Dimensions

Wrench size, union nut	15 mm
Diameter housing	22 mm
Length	44 mm
External cable diameter	4.5 mm ... 7.5 mm
Stripping length of the sheath	18 mm
Stripping length of the individual wire	4 mm +0,5 mm

Ambient conditions

Connector - SACC-P12MS-5CT-CM SH - 1021815

Technical data

Ambient conditions

Ambient temperature (operation)	-40 °C ... 85 °C (Plug / socket)
Degree of protection	IP65
	IP67
	IP68
	IP69K

General

Rated current at 40°C	4 A
Rated voltage	60 V DC
	48 V AC
Number of positions	5
Insulation resistance	≥ 100 Ω
Coding	A - standard
Standards/regulations	M12 connector IEC 61076-2-101 In line with
	Shock, vibration EN 50155:2001
Signal type/category	Universal
Status display	No
Overvoltage category	III
Degree of pollution	3
Connection method	Crimp connection
Conductor cross section	0.34 mm ² ... 1 mm ² (flexible)
Conductor cross section AWG	22 ... 18 (flexible)
Wire diameter incl. insulation	≤ 2.55 mm (Contact 5 up to max. 2.0 mm)
Insertion/withdrawal cycles	≥ 100
Torque	4 Nm (Pressure nut with coupling sleeve)

Material

Flammability rating according to UL 94	V0
Contact carrier material	PA 6.6
Material of grip body	Zinc die-cast, nickel-plated
Material, knurls	PA 6.6
Sealing material	NBR
Standards/regulations	PA 6.6: Fire protection in rail vehicles - requirement sets R22, R23, R24, and R26 acc. to DIN EN 45545-2 (Risk level HL1 - HL3)

Cable

Standards/specifications	M12 connector IEC 61076-2-101 In line with
	Shock, vibration EN 50155:2001

Standards and Regulations

Standard designation	M12 connector
Standards/regulations	IEC 61076-2-101
Standard designation	Shock, vibration

Connector - SACC-P12MS-5CT-CM SH - 1021815

Technical data

Standards and Regulations

Standards/regulations	EN 50155:2001
Flammability rating according to UL 94	V0

Environmental Product Compliance

China RoHS	Environmentally Friendly Use Period = 50
	For details about hazardous substances go to tab "Downloads", Category "Manufacturer's declaration"

Drawings

Schematic diagram

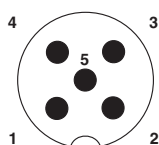

Functional drawing

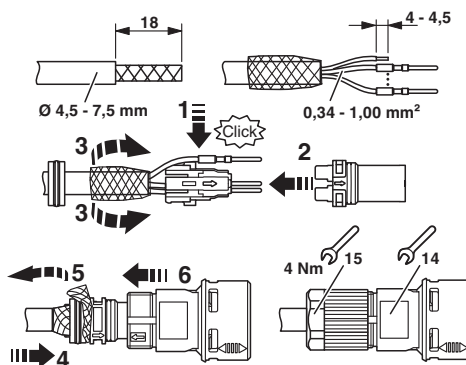

Dimensional drawing

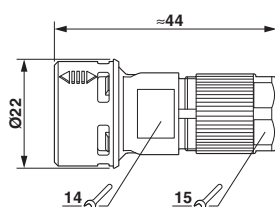

Classifications

eCl@ss

eCl@ss 9.0	27440102
------------	----------

ETIM

ETIM 5.0	EC002062
ETIM 6.0	EC002062

Approvals

Approvals

Connector - SACC-P12MS-5CT-CM SH - 1021815

Approvals

Approvals

EAC

Ex Approvals

Approval details

EAC		RU C- DE.AI30.B.01102
-----	--	--------------------------

Accessories

Accessories

Crimp contact

Crimp contact - CC1,0-TS-1,00M AU - 1423645



Crimp contact, contact diameter: 1 mm, turned, Pin, contact material: CuZn, contact surface: Ni/Au, connection cross section: 0.34 mm² ... 1 mm² AWG 22 ... 18

Crimping tool

Crimping pliers - CRIMPFOX-TC MP - 1212510



Crimping pliers, for turned contacts, universal cross section setting, up to a maximum of 2.5 mm², digital display with 0.01 mm increments, pressure lock can be unlocked, including positioning tool

Electronics pliers

Diagonal cutter - MICROFOX-SB - 1212489



Electronic diagonal cutter, round head, without chamfer, with opening spring, mirror-polished and oiled, 2-component grip, cutting capacity: soft 0.2 - 2.0 mm; medium hard 1.2 mm; hard 0.5 mm diameter

Stripping tool

Connector - SACC-P12MS-5CT-CM SH - 1021815

Accessories

Stripping tool - WIREFOX-D 13 - 1212162



Stripping tool, for stripping installation lines of \varnothing 8 - 13 mm , e.g. NYM 3 x 1.5 mm² to 5 x 2.5 mm², single line stripping 0.2 mm² - 4 mm² , with longitudinal cut blade and sliding knife

Stripping tool - WIREFOX SAC - 1212623



Stripping pliers, for halogen-free sensor/actuator cables (SAC cables), with PUR and PVC insulation, from \varnothing of 4.4 to 7 mm, any stripping length

Necessary add-on products

Crimp contact - CC1,0-TS-1,00M AU - 1423645



Crimp contact, contact diameter: 1 mm, turned, Pin, contact material: CuZn, contact surface: Ni/Au, connection cross section: 0.34 mm² ... 1 mm² AWG 22 ... 18