

Full Metal Hoods

D45ZF-RG+High Density D-Sub Solder Cup

TECHNICAL SPECIFICATIONS

D-Sub Hood:

Material: Zinc, Nickel Plated
 Operating Temperature: -45°C to + 105°C
 Cable Entry: Side Entry
 Thumbscrews: UNC 4-40 (Standard)

Cable O.D - Standard:

9-Way: Up to 6,5mm with grommet - 9,5mm without grommet
 15-Way: Up to 6,5mm with grommet - 12,5mm without grommet
 25-Way: Up to 8.0mm with grommet - 12,5mm without grommet
 37-Way: Up to 9.0mm with grommet - 15,0mm without grommet

High Density D-Sub Solder Cup:

Insulator: Glass filled TP, UL94 V-0
 Shell: Steel, Tin Plated
 Contact pins: Copper Alloy
 Stamped & Formed Pins: Class 3, 100 inserts min.
 Contact Plating: Gold flash over Nickel
 Operating Temperature: -55°C to +85°C
 Withstanding voltage: >1000V Rms to 50 Hz for 1 minute
 Current Rating: 3A
 Insulator resistance: >5000MΩ min.

Features:

- Available in sizes HD15-26-44-62
- Excellent EMI Shielding
- Re-openable
- Spring-Clip mounted Jackscrews

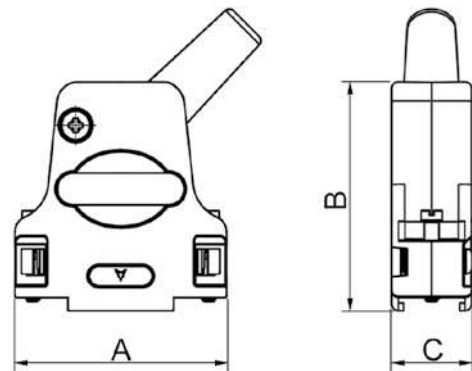

Size D45ZF	Dim A	Dim B	Dim C
9-way	31,6	39,5	15,2
15-way	40,0	41,0	15,2
25-way	53,7	47,5	15,2
37-way	70,2	48,0	15,2

Ordering information:

High Density D-Sub Connector Kits

Size:	P/N - Kitted:	Description:
HD 15	L17D45ZF09-RG+L717HDE15P	Solder Cup, 15-Male
HD 26	L17D45ZF15-RG+L717HDA26P	Solder Cup, 26-Male
HD 44	L17D45ZF25-RG+L717HDB44P	Solder Cup, 44-Male
HD 62	L17D45ZF37-RG+L717HDC62P	Solder Cup, 62-Male

Size:	P/N - Kitted:	Description:
HD 15	L17D45ZF09-RG+L77HDE15S	Solder Cup, 15-Female
HD 26	L17D45ZF15-RG+L77HDA26S	Solder Cup, 26-Female
HD 44	L17D45ZF25-RG+L77HDB44S	Solder Cup, 44-Female
HD 62	L17D45ZF37-RG+L77HDC62S	Solder Cup, 62-Female