

Z-PACK Slim UHD High Speed Connector System

1. SCOPE

This specification covers the requirements for application of the Tyco Electronics Z-PACK Slim UHD High Speed Connector System. This connector system interconnects two printed circuit boards. A complete connector is typically composed by one or more end-to-end stacked connector modules as shown in figure 1. Both pin (male) and receptacle (female) connectors are connected to the printed circuit board via compliant press-fit contacts (eye of the needle). Neither the male- nor the female connector shall be used in any other combination, than covered by this Application Specification. Other Application Specifications for similar type connectors exist. The customer drawings should be consulted to determine the correct Application Specification.

Universal guide pin and -modules are also available and can be used in conjunction with the Z-PACK Slim UHD Connector System.

2. REFERENCE DOCUMENTATION

For applicable performance requirements see the relevant Product Specification, mentioned on the customer drawing.

For configuration details see the customer drawings.

3. NOMENCLATURE

Figure 1 identifies typical features of Z-PACK Slim UHD High Speed Connector System.

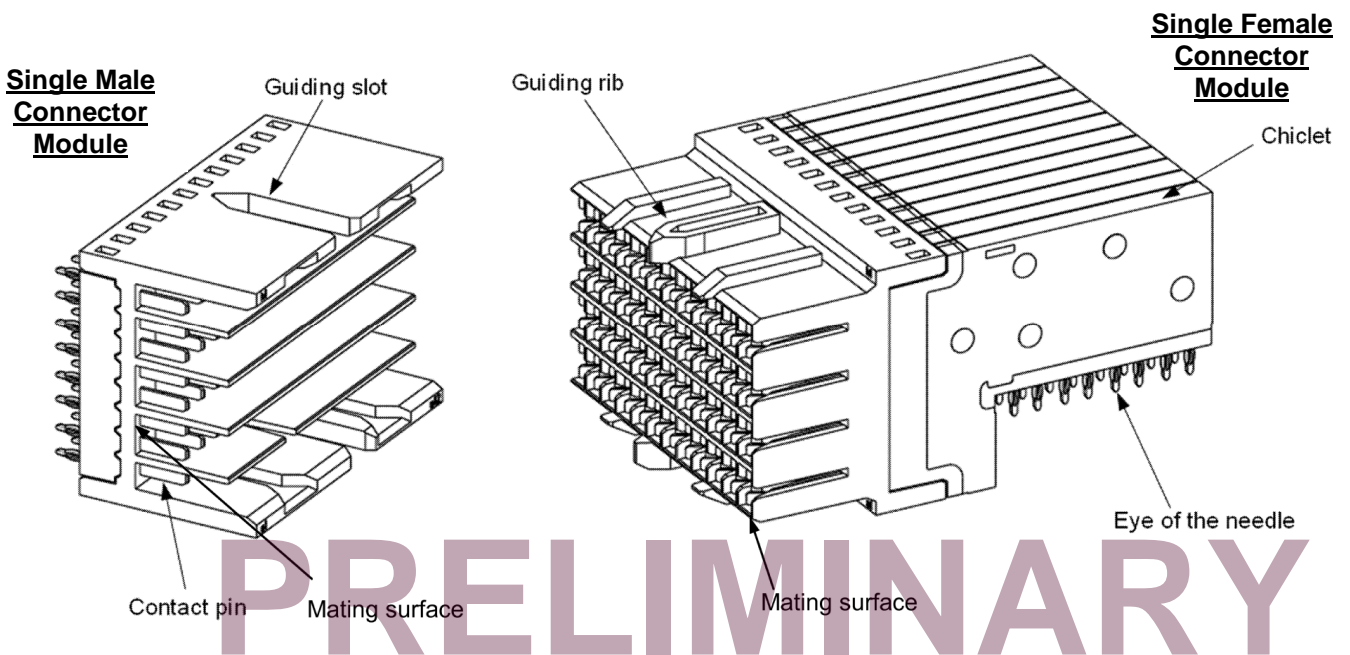

DR. Jan Broeksteeg

DATE 26 October 2007

APVD Jan Broeksteeg

DATE 26 October 2007

Figure 1 Nomenclature (cont'd)

EC EH00-xxxx-yy

Row and column identification, top view of one standard male module

		Columns											
		1	2	3	4	5	6	7	8	9	10	11	12
Rows	h	2	2	2	2	2	2	2	2	2	2	2	2
	g	2	2	2	2	2	2	2	2	2	2	2	2
	f	2	2	2	2	2	2	2	2	2	2	2	2
	e	2	2	2	2	2	2	2	2	2	2	2	2
	d	2	2	2	2	2	2	2	2	2	2	2	2
	c	2	2	2	2	2	2	2	2	2	2	2	2
	b	2	2	2	2	2	2	2	2	2	2	2	2
	a	2	2	2	2	2	2	2	2	2	2	2	2

2 = pin level identification

Accessories:

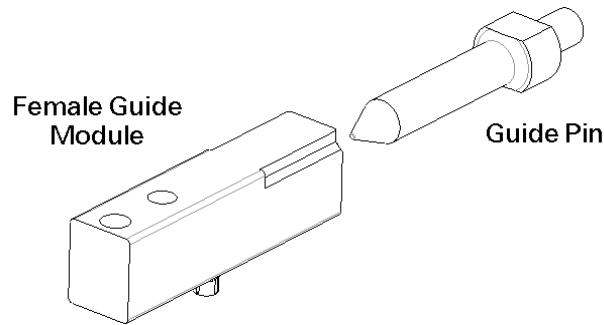

Figure 1 Nomenclature (end)

4. REQUIREMENTS

4.1 Connector Packaging, Storage and Handling

The modules should remain in the shipping containers until ready for use, to prevent damage and contamination. They should be used on a first-in/first-out basis to avoid storage contamination that could adversely affect connector performance.

4.2 Connector Interface

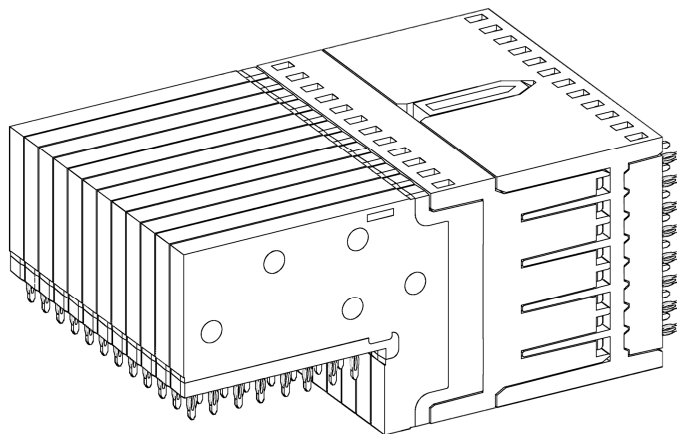

Figure 2 Fully mated connector pair

4.2.1 Mating part

Male- and Female Connectors are designed as a connector pair. Neither the male- nor the female connector shall be used in any other combination, than covered by this application specification and product specification.

Z-PACK Slim UHD is a unique board-to-board interconnection system and is available in different signal integrity performance levels (High Speed and Common Speed), quality levels and mechanical keying versions.

4.2.2 Mating and misalignment

Mating of male and female connectors shall be as shown in figure 3. A complete connector is composed by stacking one or more connector modules end to end. All modules are 17,3 mm long. One single module has all the features of a complete connector and can be used on his own.

Misalignment at mating:

Proper alignment is essential to ensure failure free engagement and disengagement of male and female connectors. For tolerance limitations, see Figure 3. The 1,0 mm max misalignment (both directions) will be corrected by the connector system.

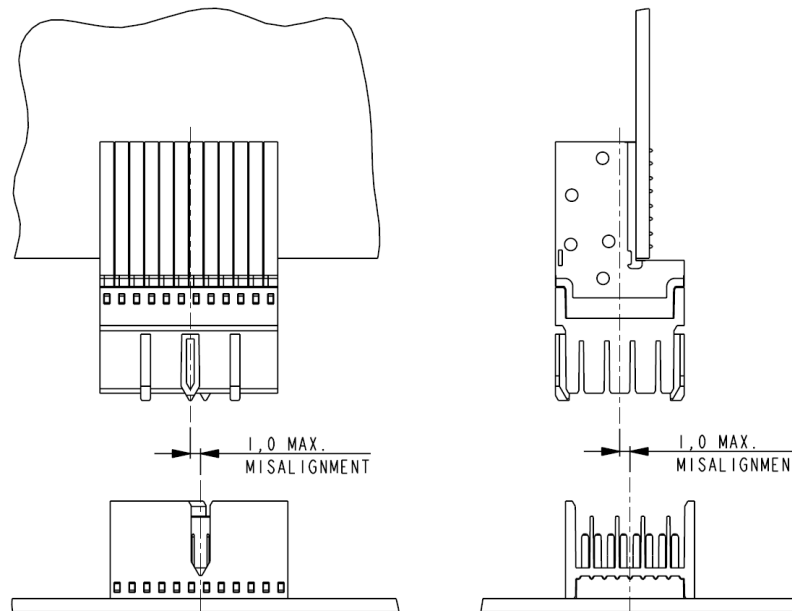

Figure 3 Alignment (cont'd)

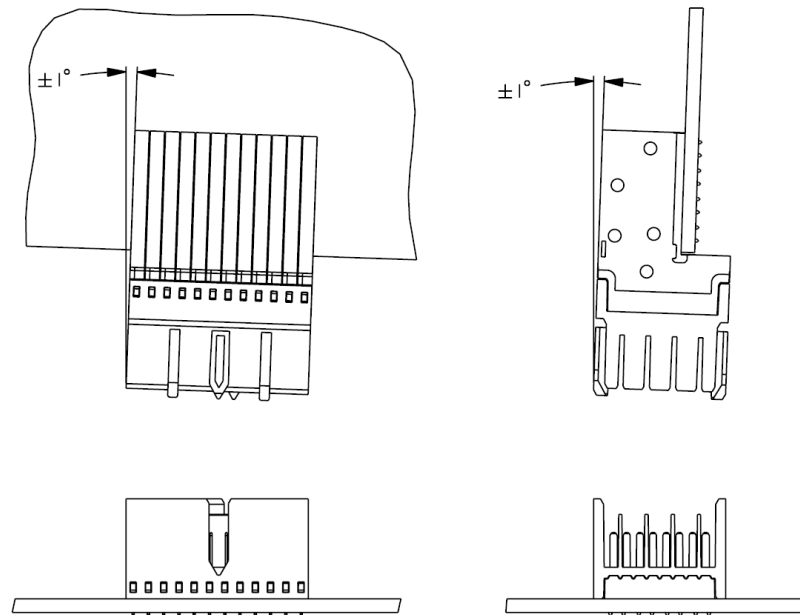

Figure 3 Alignment (end)

Although inclination of max 1° is accepted during initial connector engagement, the system will partially correct the inclination during further engagement.

The construction in the application shall provide proper guiding to comply with above requirements. System guiding shall not limit the connector movement during mating. The before mentioned additional guide pin and -modules are available from Tyco Electronics.

4.2.3 Mating and insertion depth

Full mating of connectors is recommended to ensure a good connection and to obtain the best signal transmission performance. For nominal connector conditions and a fully seated male connector (onto the pc board) the distance between the top surface of the back plane and the first row of the receptacle connector is 17,3 mm and 17,4 mm for maximum connector conditions.

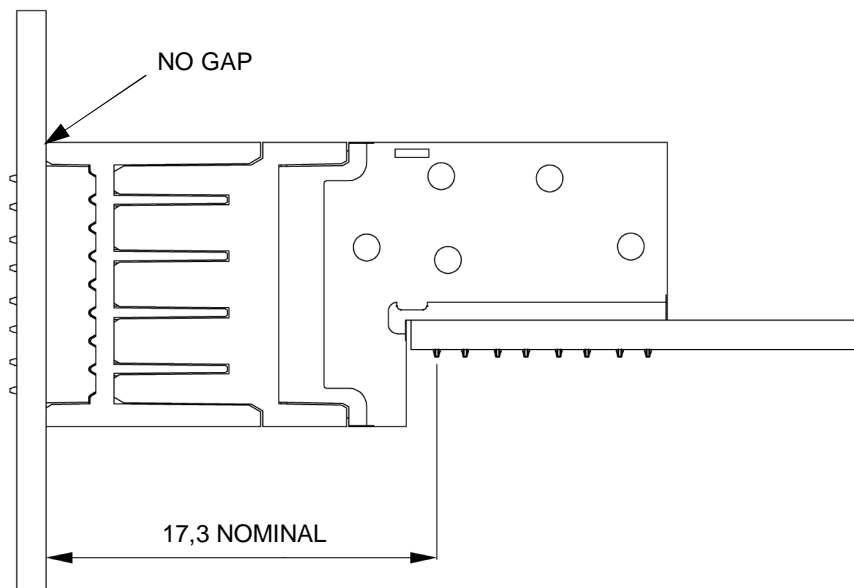

Figure 4 Insertion Depth

4.3 Sequencing and wipe length

4.3.1 Sequencing

In order to have an earlier engagement of specific contacts, four levels of sequencing are defined. The different lengths of the male pins are measured from the mating surface (fully mated) of the connector module

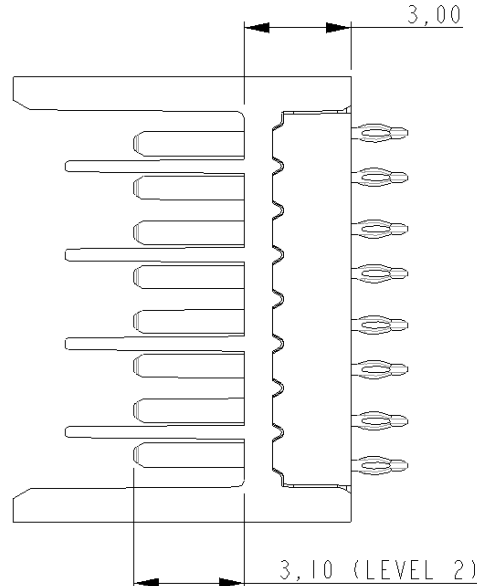

Figure 5 Pin Length

- Level 1 has a pin length of 2,25 mm
- Level 2 has a pin length of 3,10 mm
- Level 3 has a pin length of 3,55 mm
- Level 4 has a pin length of 4,65 mm

The following rules apply to the usage of these levels:

- 1 Last make - first break and first make - last break options require that the level 1 or level 4 pins are positioned at the far end corners of a connector.
- 2 Level 1 pin is defined to address last make - first break requirements and will be offered on one corner position of a module only. The position of the level 1 contact can be found on the respective customer drawings. A level 1 pin must be surrounded by ground or single ended pins.
- 3 Level 2 pin is defined to address signal transmission with excellent signal integrity properties and is offered as the standard contact.
- 4 Level 3 pin is defined to address signal transmission with excellent signal integrity properties. The contact is offered as alternative to level 2 and can be applied if two or more connector modules are used in one slide-in unit. One connector can now have level 2 pins, where an other connector has level 3 pins. This reduces the insertion forces of the slide-in unit in case multiple connectors are used.
- 5 Level 2 and level 3 pins are not offered in one module and may not be used in the same connector.
- 6 Level 4 pin is defined to address first make - last break requirements and will be offered on one corner position of a module only. The position of the level 4 contact can be found on the respective customer drawings. A level 4 pin must be surrounded by ground or single ended pins.
- 7 Level 1 and level 4 pins can be combined in one module, but will then always be placed in the same column. See respective customer drawings for details.

4.3.2 Wipe length

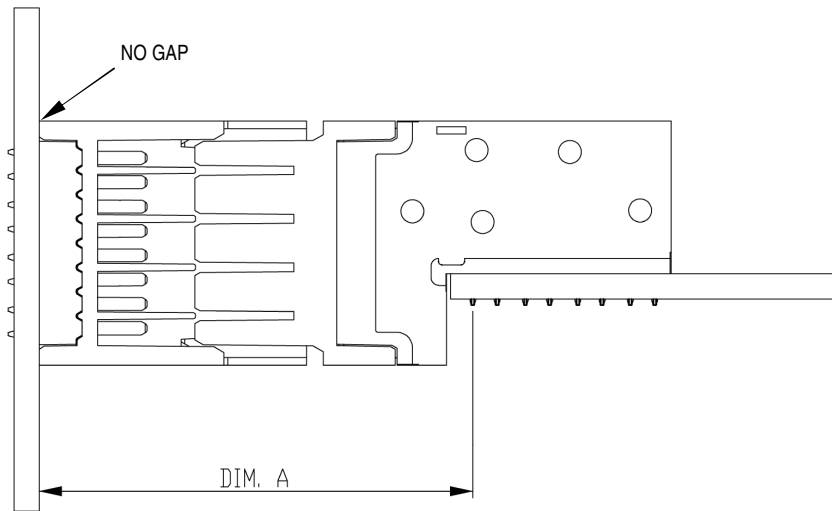

(Dimensions in mm's)	Dimension "A"		Fully mated wipe length (see para. 4.2.3)
	Reliable mating point Fig 7	First Make Sequencing Point Fig 8	
Level 4	20,65	21,42	3,35
Level 3	19,55	20,32	2,25
Level 2 (standard contact length)	19,10	19,87	1,80
Level 1	18,25	19,02	0,95

Figure 6 Mating dimensions and wipe length

Connector wipe dimensions are shown in Figure 6. Wipe lengths are calculated by subtracting the fully mated connector condition from the reliable mating point as shown in Figure 6.

In case of level 1 contacts, the contacts are designed such that under the conditions specified in 4.2.2 level 1 pins first mate with the female contact (Figure 8), after all other contacts are at the reliable mating point (Figure 7).

In case of level 4 contacts, the contacts are designed such that under the conditions specified in 4.2.2 level 4 pins are at their reliable mating point (Figure 7), before all other contacts are at the first possible mating point (Figure 8).

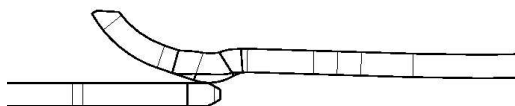

Figure 7 Reliable mating point

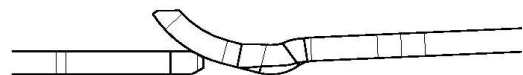

Figure 8 First possible mating point

All dimensions are calculated using nominal connector conditions. Connectors are assumed to be seated flush with the pc board.

4.4 Differential pairs and pin assignment

The Z-PACK Slim UHD High Speed connector has excellent signal transmission quality, when used in combination with differential pair assignments. Differential pair assignments in combination with Z-PACK Slim UHD High Speed are only allowed if the assignment is according the following rules:

- 1 Every differential pair assigned in-column must be adjacent to either another differential pair (arranged in the same rows) or adjacent to ground or single ended pins in the adjacent columns; with a maximum of six differential pairs assigned per three connector columns.
- 2 Every differential pair assigned in-column must be adjacent to ground in the same column.
- 3 A level 4 pin, used for first make – last break, should never be adjacent to a differential pair, neither in column, nor in row.
- 4 A level 1 pin, used for last make – first break, should never be adjacent to a differential pair, neither in column, nor in row.

Figure 9 shows commonly used differential pair assignments according the rules above:

		Columns											
		1	2	3	4	5	6	7	8	9	10	11	12
Rows	h	D		D		D		D		D		D	
	g	D		D		D		D		D		D	
	f		D		D		D		D		D		D
	e		D		D		D		D		D		D
	d	D		D		D		D		D		D	
	c	D		D		D		D		D		D	
	b		D		D		D		D		D		D
	a		D		D		D		D		D		D

2.0 Differential Pairs per column.
All contacts have level 2 or 3.
Signal to Ground ratio 1:1

		Columns											
		1	2	3	4	5	6	7	8	9	10	11	12
Rows	h	D		D		D		D		D			1
	g	D		D		D		D		D			
	f		D		D		D		D		D		
	e		D		D		D		D		D		
	d	D		D		D		D		D			
	c	D		D		D		D		D			
	b		D		D		D		D		D		
	a		D		D		D		D		D		4

2.0 Differential Pairs per column combined with single ended or ground contacts.
Level 1 and Level 4 contacts possible at corner positions.

	Level 2 or 3
1	Level 1
4	Level 4

		Columns											
		1	2	3	4	5	6	7	8	9	10	11	12
Rows	h	D		D		D		D		D		D	
	g	D		D		D		D		D		D	
	f												
	e	D		D		D		D		D		D	
	d	D		D		D		D		D		D	
	c												
	b	D		D		D		D		D		D	
	a	D		D		D		D		D		D	

1.5 Differential Pairs per column.
All contacts have level 2 or 3.

Figure 9 Pin Assignments (cont'd)

		Columns											
		1	2	3	4	5	6	7	8	9	10	11	12
Rows	h		D		D								1
	g		D		D				D		D		
	f								D		D		
	e			D		D				D		D	
	d			D		D				D		D	
	c								D		D		
	b		D		D				D		D		
	a		D		D								4

	Level 2 or 3
1	Level 1
4	Level 4

1.5 Differential pair per column (2 examples) combined with single ended or ground contacts. Level 1 and Level 4 contacts possible at corner positions.

		Columns											
		1	2	3	4	5	6	7	8	9	10	11	12
Rows	h	D		D		D	D					D	
	g	D		D		D	D			D		D	
	f		D							D		D	
	e		D			D	D		D		D		
	d	D		D		D	D		D		D		
	c	D		D						D		D	
	b		D				D	D		D		D	
	a		D				D	D					

Various differential pair assignments combined with single ended and ground contacts. All contacts have level 2 or 3.

		Columns											
		1	2	3	4	5	6	7	8	9	10	11	12
Rows	h												1
	g												
	f												
	e												
	d												
	c												
	b												
	a												4

	Level 2 or 3
1	Level 1
4	Level 4

All contacts single ended or ground contacts. Level 1 and Level 4 contacts possible at corner positions.

Figure 9 Pin Assignments (end)

4.5 Mechanical Stability

The construction in the application shall provide mechanical stability in order to comply with the requirements specified in paragraph 4.2.2 and 4.2.3. This must avoid unacceptable force load on the connectors as well as on the pc board connection.

4.6 Abuse and misuse

The construction in the application shall assure that abuse and misuse will not lead to damage on the connectors.

4.7 Printed Circuit Board

4.7.1 Lay-out

The pc board layout shall be as specified on customer drawings.

4.7.2 Board Thickness

Fixed boards (back panel) as well as free boards (daughter boards) shall have a thickness of 1,4 mm minimum.

4.7.3 Printed Circuit Board hole configuration

The holes in the pc board for all contacts must be drilled and plated through to the dimensions shown in Figure 10.

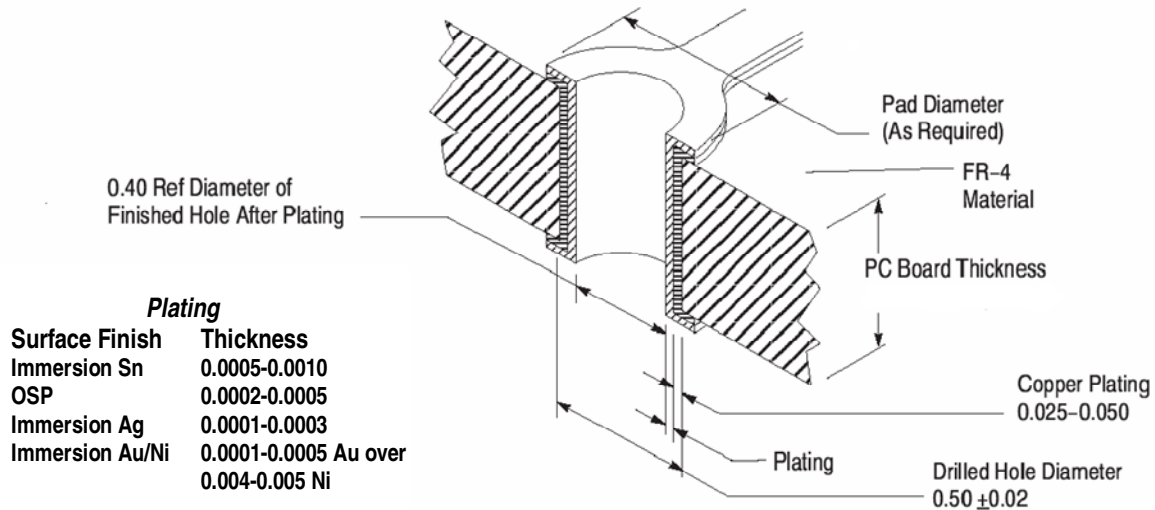

(PTH Counterboring)

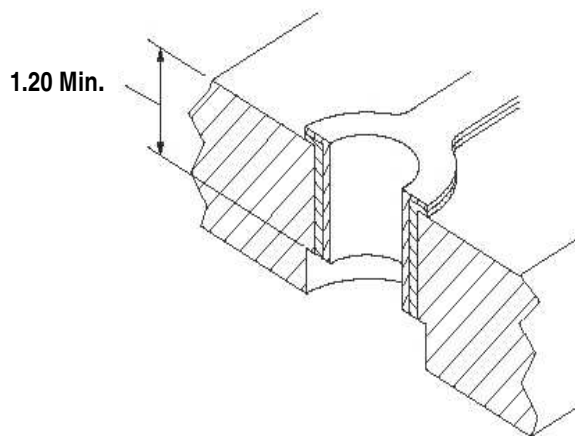

All dimensions in mm's

Figure 10 Plated through hole

4.8 Module Stacking

Modules can be stacked together without change of contact pitch. A connector is composed by one or multiple end-to-end stacked modules as shown in figure 11.

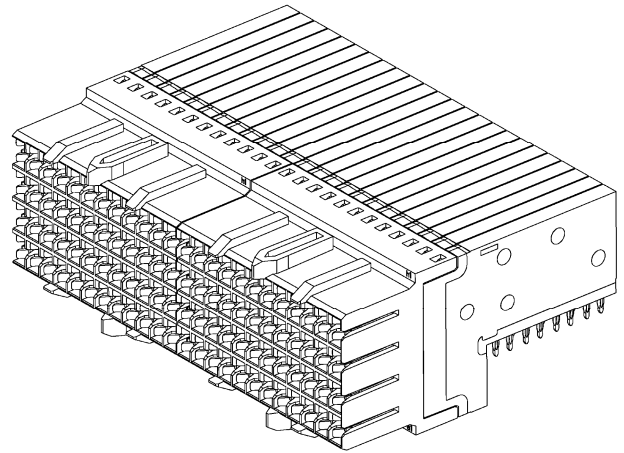
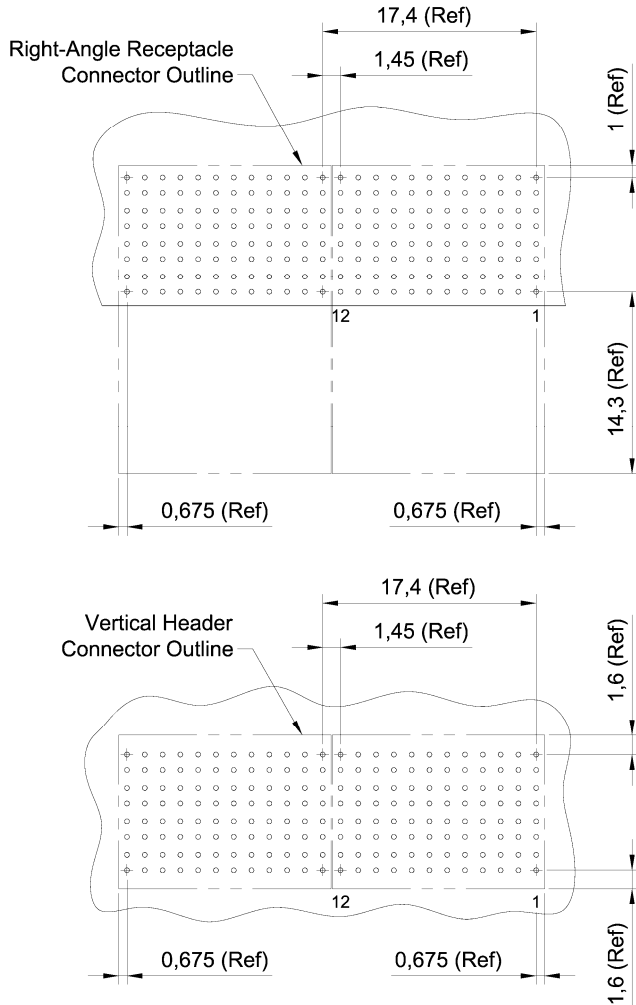

Female connector

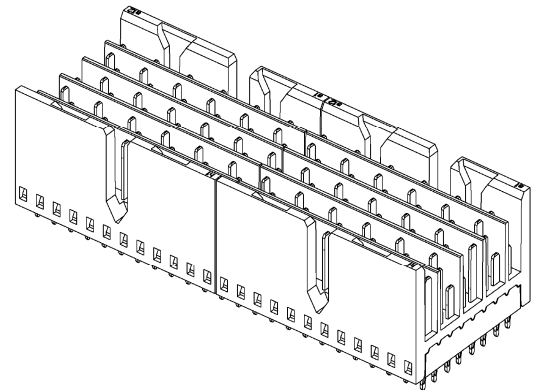

Male connector

Figure 11 Printed Circuit Board Lay-out for stacked modules

4.9 Visual examination

The final product shall not be deformed and the plating shall not be scratched.

4.10 Repair

Both the male and female module construction does not allow for replacement of individual contacts. Damaged modules must be completely replaced and insertion of a new connector module into the previously used hole is permissible.

5. CONNECTOR INSTALLATION

5.1 Initial positioning

Z-PACK Slim UHD modules typically are pre-applied to a pc board by hand. Connectors should be gripped by the housing and/or contact chiclets only and not by the contacts. When placing a module or complete connector into a pc board, all contact leads should be aligned and inserted into the pc board simultaneously to prevent twisting or bending of the contacts.

When placing a female module on a pc board, align the row of contact leads closest to the pc board edge first, and continue aligning the remainder of the rows by rolling the receptacle from front to back.

The male modules are not symmetrical and must be oriented properly on the pc board with regard for pin a1 orientation (see customer drawing).

5.2 Seating connectors

It is preferred to seat individual modules over completed connectors. Seating force must be applied evenly on the connectors to prevent deformation or other damage to the contacts and housings. When installing male modules or connectors, the insertion force must be evenly applied to the assembly using the appropriate seating tool. When installing female receptacle modules or connectors, the insertion force must be evenly applied to the assembly (as shown in Figure 12). Refer to paragraph 5.3 for seating force information. Seating force will vary according to pc board variations and signal pin count. Tooling recommendations are covered in Section 7.

CAUTION

Correct seating is essential to interconnection performance. This includes correct seating height (see Figure 12) and force applied. Over-seating of product will deform parts critical to the quality of the connector. Maximum force occurs prior to bottoming on the pc board.

5.3 Connector seating height

Z-PACK Slim UHD Connectors with Eye of the Needle pin contacts are seated using a seating tool insert. See Figure 12. The insert may be used together with the application machines listed in Section 7, TOOLING, or with a suitable machine capable of supplying a minimum controllable downward force of 50N per press-in pin contact. Male modules must be seated to the dimension shown in the figure.

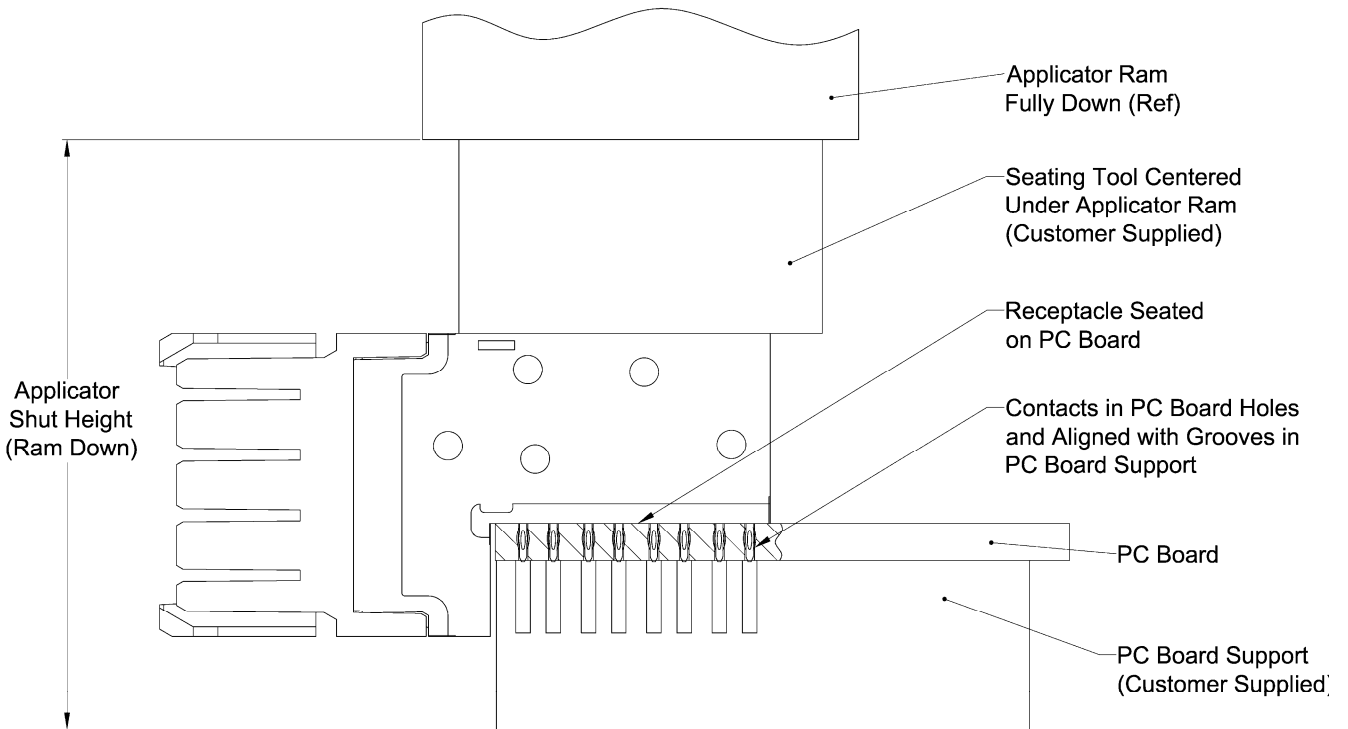
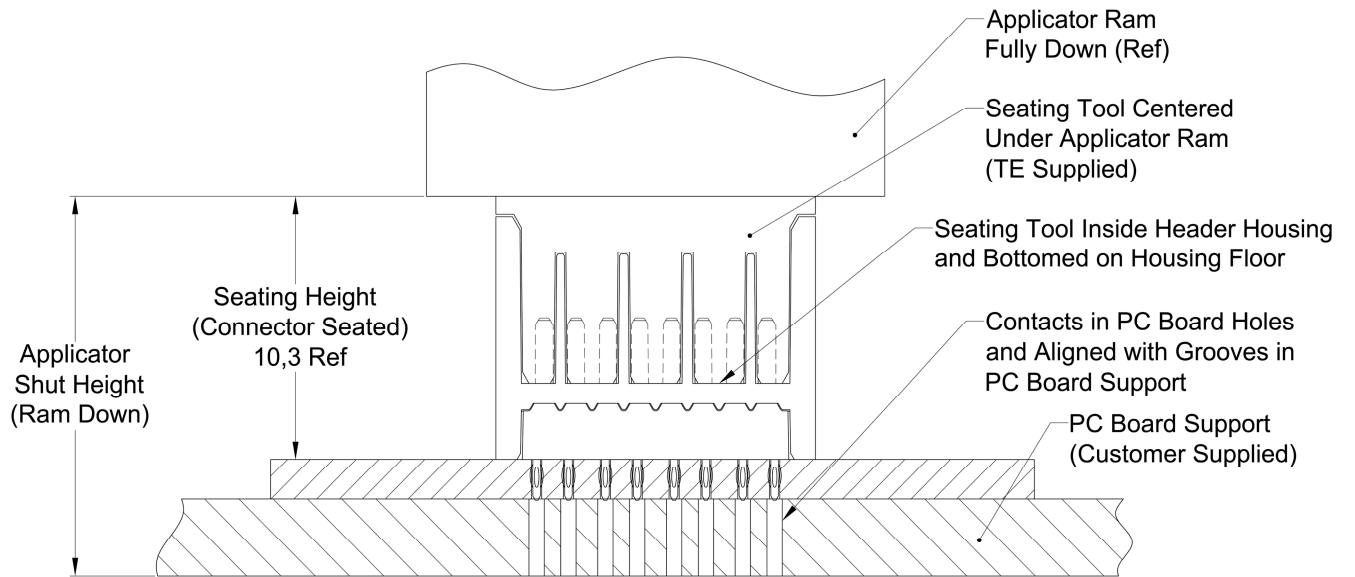

Figure 12 Seating height

6. **ACCESSORIES**

6.1 **Guide modules and pins**

The guides modules and pins are recommended for multi-module, large and heavy daughter card applications, and conditions where misalignment tolerances (given in Figure 3) cannot be met. Recommended spacings are given in Figure 13.

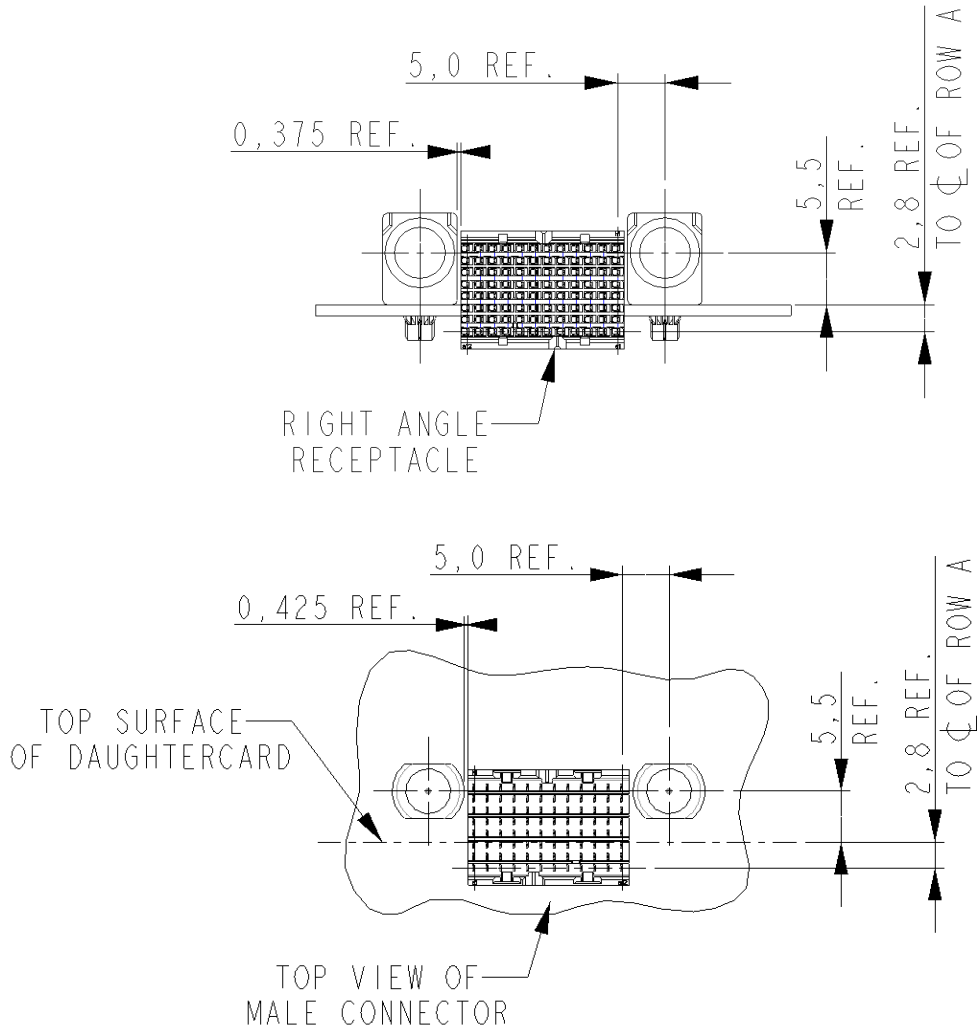

Figure 13 Recommended Guide Hardware Spacing Dimensions

7. TOOLING

Figure 15 provides typical tools related to the Z-PACK Slim UHD Connector System.

1 Power Units

Power units are automatic or semi-automatic machines used to assist in the application of a product. A power unit supplies the force to seat the connector onto the pc board using seating tools. Power for the insertion tool must be provided by application tools (with a ram) capable of supplying a downward force of 50 N per contact.

Typical power units from Tyco Electronics Automation Group include, but are not limited to the following:

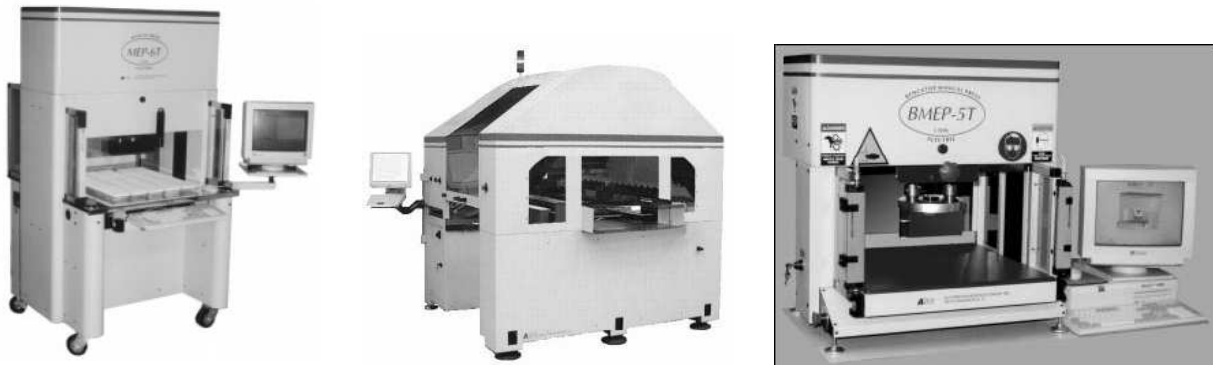

Model MEP 6T
1585699-1

Model AP3
1585280-1

Model BMEP 5T
1585696-1

Figure 14 Power Units

2 Arbor Frame Assembly

Manual arbor frame assemblies are used to exert a downward force used to apply modules to a pc board using seating tools. Commercially made arbor frame assemblies are available.

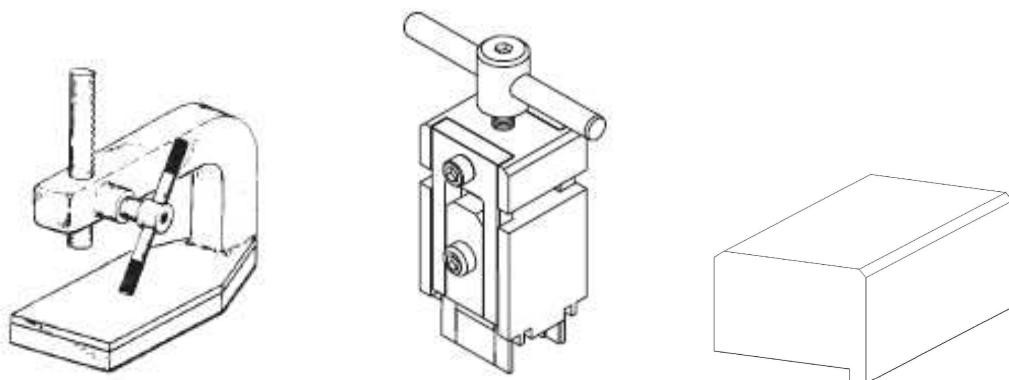

Manual Arbor frame assembly
(Commercially Available)

Typical Male Connector
Removal Tool

Typical Receptacle
Seating Tool

Figure 15 Typical Application Tools

3 PC Board Support

A pc board support must be used to prevent bowing of the pc board during the insertion of a module into the board. It should have flat surfaces with holes or a channel wide and deep enough to receive any contacts that may protrude below the pc board surface during seating of the connector.

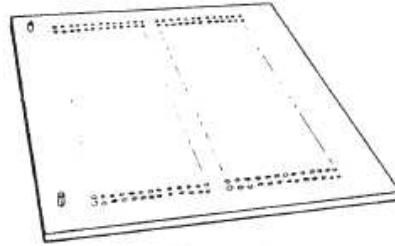

Figure 16
PC Board Support (Customer Supplied)

4 Seating Tool (Insert) for male modules.

Seating tools have been designed to push on the preferred surface and seat the connector on the pc board. The tool will prevent contacts from backing out of the housing and prevent damage to the module.

8. VISUAL AID

Figure 17 shows a typical application of the Z-PACK Slim UHD Connector System. This illustration should be used by production personnel to ensure a correctly applied product. Applications which DO NOT appear correct should be inspected using the information in the preceding pages of this specification and in the instructional material shipped with the product.

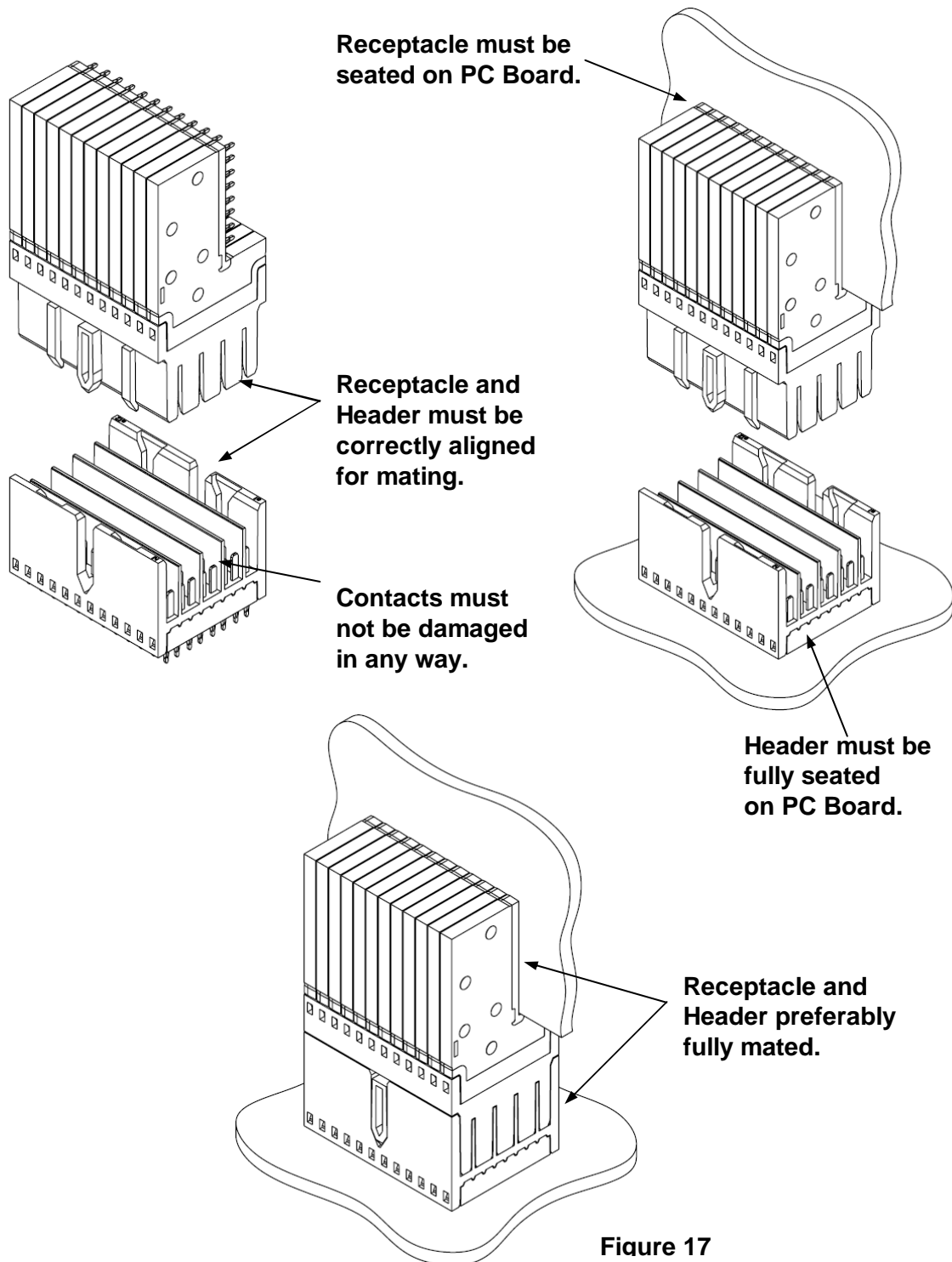

Figure 17

Appendix A

Routing Guide

1. CONNECTOR FOOTPRINT

The Z-PACK Slim UHD footprint is identical on both backplane and daughter card. The footprint has 1.45mm routing channels in both horizontal & vertical direction. Press-fit technology is used to mount the connector on the board; the finished hole diameter is 0.4mm.

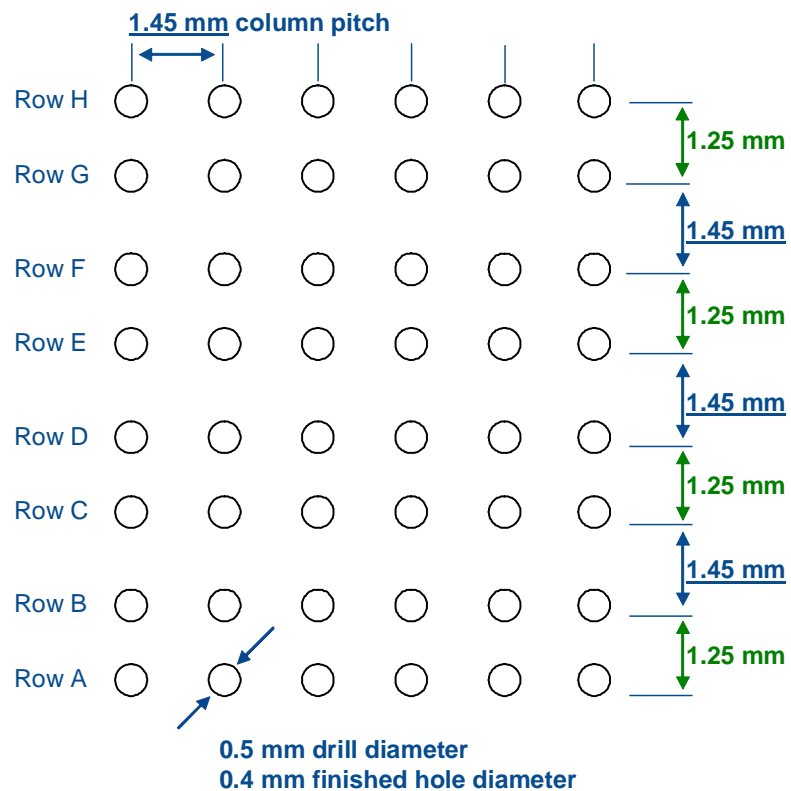

Same footprint on backplane and daughtercard

Figure 1: Z-PACK Slim UHD Connector Footprint

2. **FOOTPRINT ROUTING**

In the Z-PACK Slim UHD footprint, the spacing between the two legs of a differential pair depends on the connector row. The inner pair spacing of differential pair assignments on rows A-B, C-D, E-F and G-H is 1.25mm. The inner pair spacing of differential pair assignments on rows B-C, D-E and F-G is 1.45mm. In this document, differential pairs assigned on rows that are spaced 1.25mm apart are called PAIR 1 and differential pairs assigned on rows that are spaced 1.45mm apart are called PAIR 2.

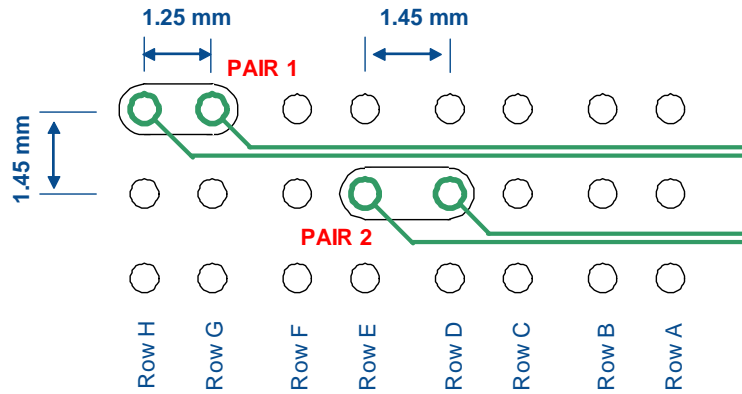

Figure 2: Differential spacing

The below figure shows the footprint routing of the Z-PACK Slim UHD connector when two differential pairs per column are routed.

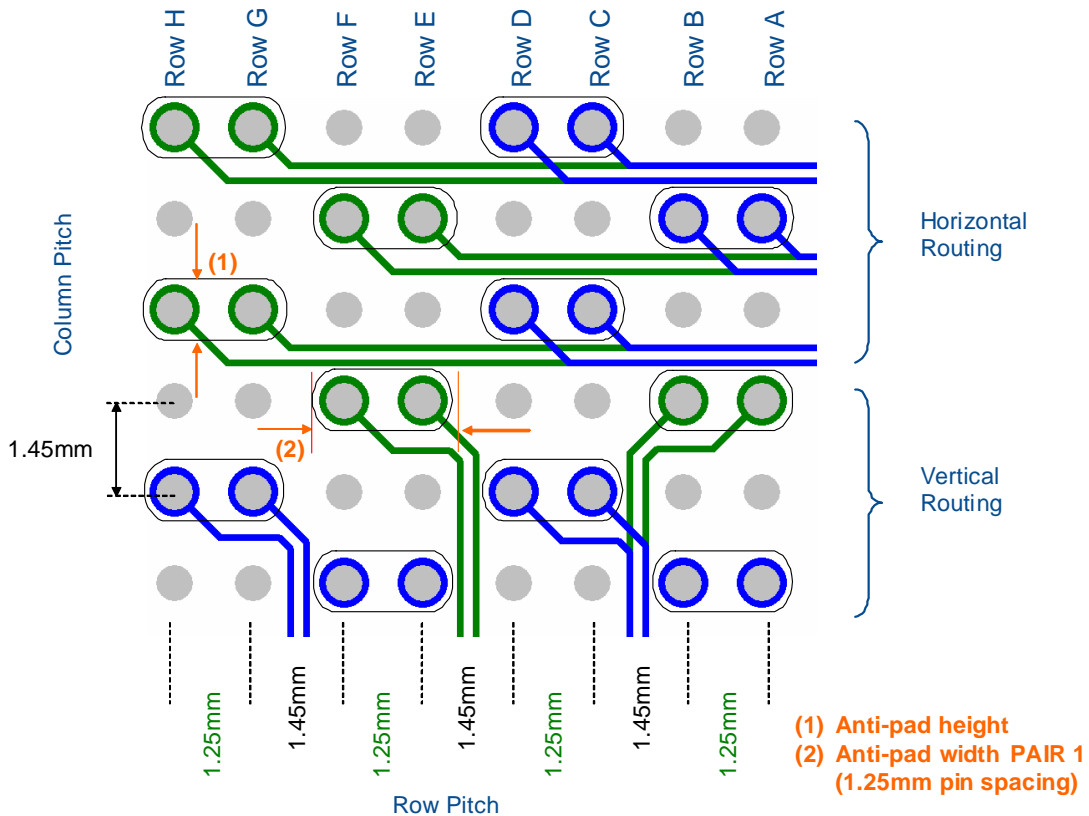

Figure 3: Connector footprint routing (S:G = 1:1 or 2 diff. pairs / column)

3. ROUTING CHANNELS

In the following section, the available routing channels through the Z-PACK Slim UHD footprint are calculated. The figure below identifies the different symbols that are used throughout this document.

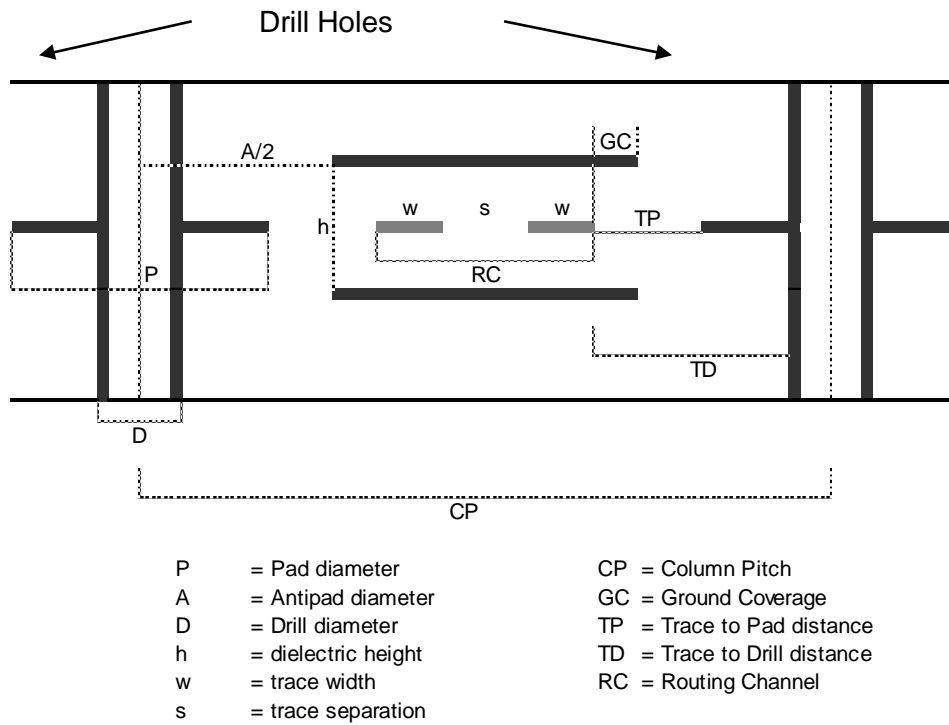

Figure 4: Trace Configuration

In the table below, the routing channel dimensions are listed based on values for the anti-pad height and the trace ground coverage.

General		Column Pitch	1.45	mm					
		Drill Diameter (D)	0.50	mm					
Property	Pad Technology	Pad Diameter (P)	Anti-Pad Height (A)	Anti-Pad Width PAIR_1	Anti-Pad Width PAIR_2	Ground Coverage (GC)	Trace-to-Pad (TP) (*)	Trace-to-Drill (TD)	Routing Channel (RC)
Units		mm	mm	mm	mm	µm	mm	mm	mm
						50	0.125	0.250	0.45
			0.90	2.15	2.35	75	0.150	0.275	0.40
						100	0.175	0.300	0.35
	D + 0.25mm	0.75				25	0.125	0.250	0.45
	(D + 10mil)		0.95	2.20	2.40	50	0.150	0.275	0.40
						75	0.175	0.300	0.35
			1.00	2.25	2.45	25	0.150	0.275	0.40
						50	0.175	0.300	0.35
			1.05	2.30	2.50	25	0.175	0.300	0.35
						75	0.125	0.275	0.40
						100	0.150	0.300	0.35
	D + 0.30mm	0.80				50	0.125	0.275	0.40
	(D + 12mil)		0.95	2.20	2.40	75	0.150	0.300	0.35
			1.00	2.25	2.45	25	0.125	0.275	0.40
						50	0.150	0.300	0.35
			1.05	2.30	2.50	25	0.150	0.300	0.35
						100	0.125	0.300	0.35
	D + 0.35mm	0.85				75	0.125	0.300	0.35
	(D + 14mil)		0.95	2.20	2.40	50	0.125	0.300	0.35
			1.00	2.25	2.45	50	0.125	0.300	0.35
			1.05	2.30	2.50	25	0.125	0.300	0.35

Remarks

- PAIR_1 = Differential pair 1.25mm spaced (Pair AB, Pair CD, Pair EF, Pair GH)
- PAIR_2 = Differential pair 1.45mm spaced (Pair BC, Pair DE, Pair FG)
- Configurations are shown for Ground Coverage (GC) values of 25, 50, 75 and 100 µm
- Configurations are shown for TP >= 0.125 mm
- (*) Assuming trace edge coincides with edge of routing channel

4. **ENHANCED ROUTING**

The routing space through the Z-PACK Slim UHD footprint can be improved by shifting the centre line of the differential pair towards a ground via. The ground via is connected to the ground layers within the PCB, therefore, ground coverage is always ensured at this side.

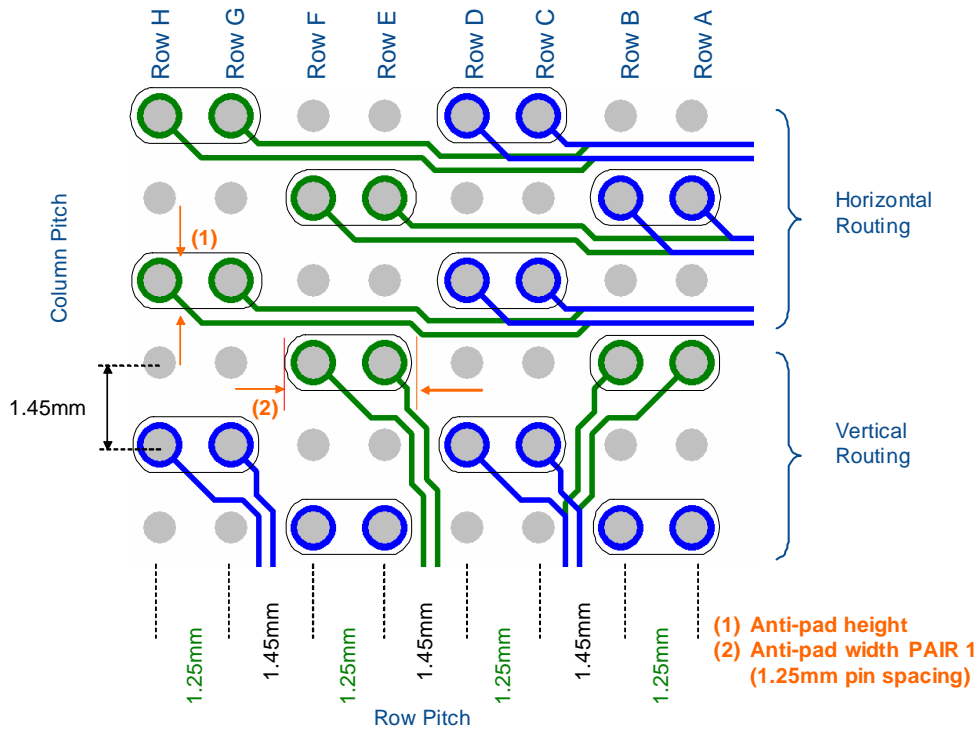

Shift of the differential pair towards a ground via:

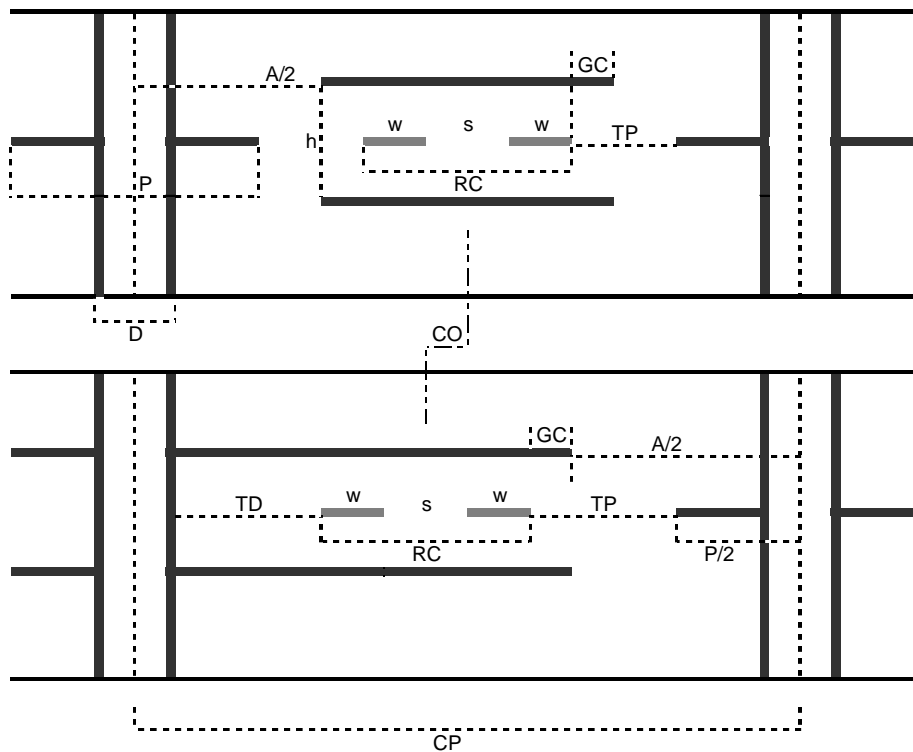

The following table gives an overview of the possible routing channels when the centre line of the differential trace is shifted. The calculations are based on certain values for pad, anti-pad and trace ground coverage. The anti-pad width values given are assuming the use of oval anti-pads.

General		Column Pitch	1.45	mm							
General		Drill Diameter (D)	0.50	mm							
General		Centre Line Offset (CO)	75	µm							
Property	Pad Technology	Pad Diameter (P)	Anti-Pad Height (A)	Anti-Pad Width PAIR_1	Anti-Pad Width PAIR_2	Ground Coverage (GC)	Trace-to-Pad (TP) (*)	Trace-to-Drill (TD) (*)	Routing Channel (RC)	TP when CO=0	GC when CO = 0
Units		mm	mm	mm	mm	µm	mm	mm	mm	mm	µm
			0.90	2.15	2.35	100	0.175	0.150	0.50	0.100 (**)	25
						125	0.200	0.175	0.45	0.125	50
			0.95	2.20	2.40	75	0.175	0.150	0.50	0.100 (**)	0 (***)
	D + 0.25mm	0.75				100	0.200	0.175	0.45	0.125	25
	(D + 10mil)					125	0.225	0.200	0.40	0.150	50
			1.00	2.25	2.45	75	0.200	0.175	0.45	0.125	0 (***)
						100	0.225	0.200	0.40	0.150	25
						125	0.250	0.225	0.35	0.175	50
			1.05	2.30	2.50	75	0.225	0.200	0.40	0.150	0 (***)
						100	0.250	0.225	0.35	0.175	25
			0.90	2.15	2.35	125	0.175	0.175	0.45	0.100 (**)	50
			0.95	2.20	2.40	100	0.175	0.175	0.45	0.100 (**)	25
	D + 0.30mm	0.80				125	0.200	0.200	0.40	0.125	50
	(D + 12mil)					75	0.175	0.175	0.45	0.100 (**)	0 (***)
			1.00	2.25	2.45	100	0.200	0.200	0.40	0.125	25
						125	0.225	0.225	0.35	0.150	50
			1.05	2.30	2.50	75	0.200	0.200	0.40	0.125	0 (***)
						100	0.225	0.225	0.35	0.150	25
			0.95	2.20	2.40	125	0.175	0.200	0.40	0.100 (**)	50
	D + 0.35mm	0.85				100	0.175	0.200	0.40	0.100 (**)	25
	(D + 14mil)					125	0.200	0.225	0.35	0.125	50
			1.05	2.30	2.50	75	0.175	0.200	0.40	0.100 (**)	0 (***)
						100	0.200	0.225	0.35	0.125	25

- PAIR_1 = Differential pair 1.25mm spaced (Pair AB, Pair CD, Pair EF, Pair GH)
- PAIR_2 = Differential pair 1.45mm spaced (Pair BC, Pair DE, Pair FG)
- Configurations are shown for Ground Coverage (GC) values of 50, 75, 100 and 125 µm
- Configurations are shown for TP >= 0.125mm and TD >= 0.150mm

Remarks

- (*) Assuming trace edge coincides with edge of routing channel
- (**) Take special care when increasing the routing channel for a given pad or anti-pad diameter.
When routed centered between two pads, the trace-to-pad distance is only 0.1mm
- (***) Take special care when increasing the routing channel for a given pad or anti-pad diameter.
When routed centered between two pads, the ground coverage is 0 mm

5. TRACE CONFIGURATIONS

Based on the available routing channel for given pad and anti-pad dimensions, the following trace widths and differential trace spacings can be chosen.

Property	Routing Channel (RC)	Trace Width (w)	Trace Spacing (s)
Units	mm	mm	mm
	0.35	0.100	0.150
	0.40	0.100	0.200
		0.125	0.150
	0.45	0.100	0.250
		0.125	0.200
		0.138	0.174
	0.50	0.150	0.150
		0.125	0.250
		0.150	0.200