



NOTE

All numerical values are in metric units [with U.S. customary units in brackets]. Dimensions are in millimeters [and inches]. Unless otherwise specified, dimensions have a tolerance of ± 0.13 [± 0.005] and angles have a tolerance of $\pm 2^\circ$. Figures and illustrations are for identification only and are not drawn to scale.

1. INTRODUCTION

This specification covers the requirements for application of wire to TE Connectivity MTA (Mass Termination Assembly) 100 connectors. These requirements are applicable to hand or automatic machine application tools. Specific wire and insulation ranges relative to the products covered in this specification are 28-22 AWG tip-plated solid, concentric fused stranded and concentric stranded wire with standard PVC thermoplastic insulation having a maximum insulation diameter of 1.52 mm [.060 in.] when terminated one position at a time, or 1.27 mm [.050 in.] when mass terminating. Stranded wire approved by TE engineering per Underwriters Laboratory Inc. (UL) Style 1007 and 1061 is 24-22 AWG 7 and 19 stranded, and 28-26 AWG 7 stranded. Other wire sizes, styles, and insulation materials shall be approved by TE.

When corresponding with TE Personnel, use the terminology provided in this specification to facilitate your inquiries for information. Basic terms and features of this product are provided in Figure 1.

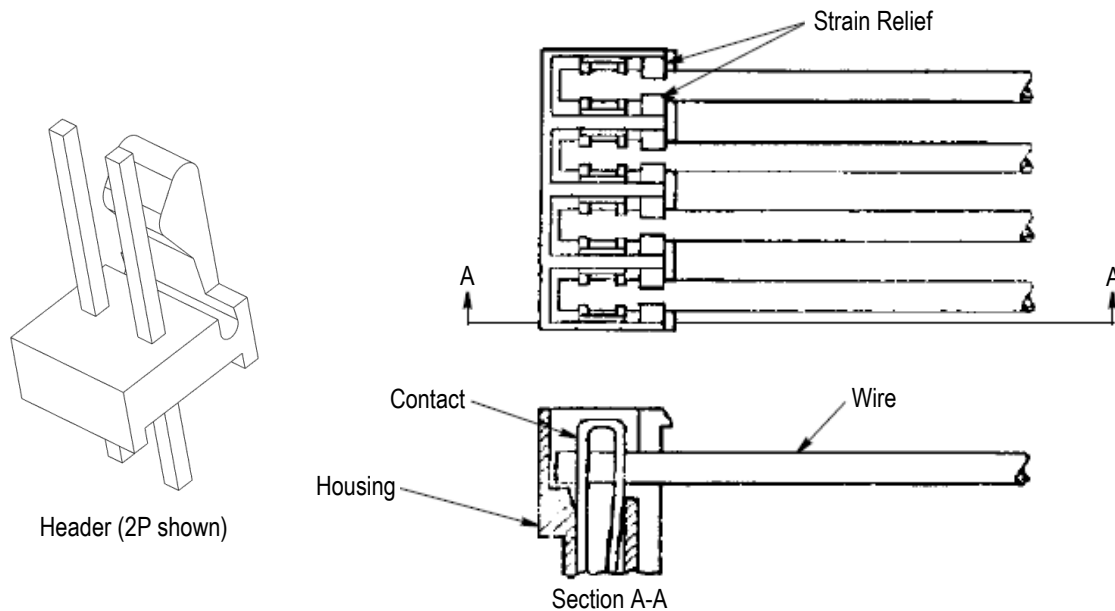

Figure 1

2. REFERENCE MATERIAL

2.1. Revision Summary

- Added Paragraph 3.9.
- Updated Figure 1 to include image of header.
- Removed reference to product code in Paragraph 2.2.

2.2. Customer Assistance

Reference Product Base Part Number 640440 is representative of MTA 100 connectors. Use of these numbers will identify the product line and help you to obtain product and tooling information when visiting www.te.com or calling the number at the bottom of page 1.

2.3. Drawings

Customer drawings for product part numbers are available from www.te.com. Information contained in the customer drawing takes priority.

2.4. Specifications

Product Specification 108-1050 provides product performance and test results.

3. REQUIREMENTS

3.1. Safety

Do not stack product shipping containers so high that the containers buckle or deform.

3.2. Storage

A. Ultraviolet Light

Prolonged exposure to ultraviolet light may deteriorate the chemical composition used in the product material.

B. Shelf Life

The product should remain in the shipping containers until ready for use to prevent deformation to components. The product should be used on a first in, first out basis to avoid storage contamination that could adversely affect performance.

C. Chemical Exposure

Do not store product near any chemical listed below as they may cause stress corrosion cracking in the material.

Alkalies	Ammonia	Citrates	Phosphates	Citrates	Sulfur Compounds
Amines	Carbonates	Nitrites	Sulfur Nitrites		Tartrates

3.3. Wire Termination

After termination, wire shall meet the requirements specific in Figure 2.

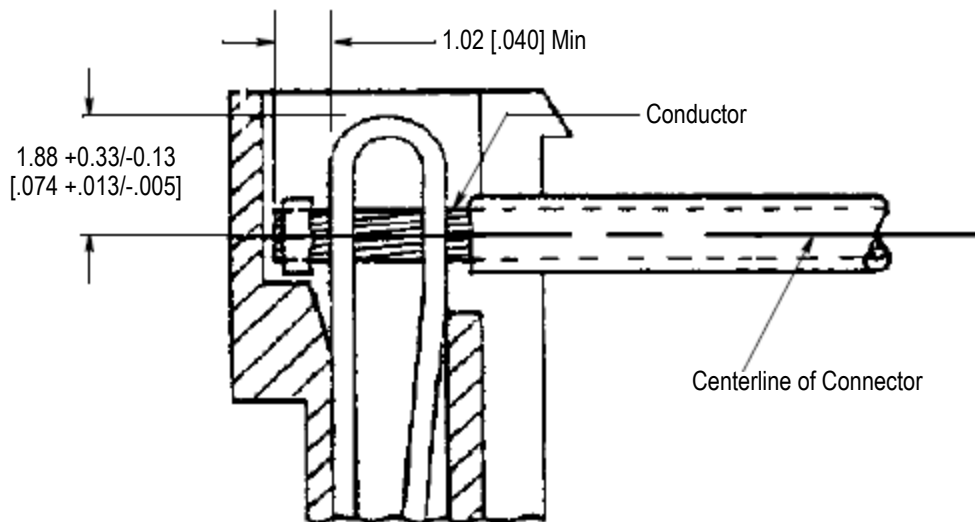

Figure 2

3.4. Contact Damage

There shall be no evidence of physical damage or distortion to any portion of the contact after wire termination.

3.5. Housing Damage

There shall be no cracks, breaks, or other visible damage to the housing due to wire termination.

Skiving of plastic on the inside wall of the housing cavity is permissible, provided that conditions specified in the previous statement are met.

3.6. Broken Strands

There shall be no broken strands in the conductor after termination.

3.7. Exposed Conductor

Exposed conductors shall not exceed the limits specified in Figure 3 after termination.

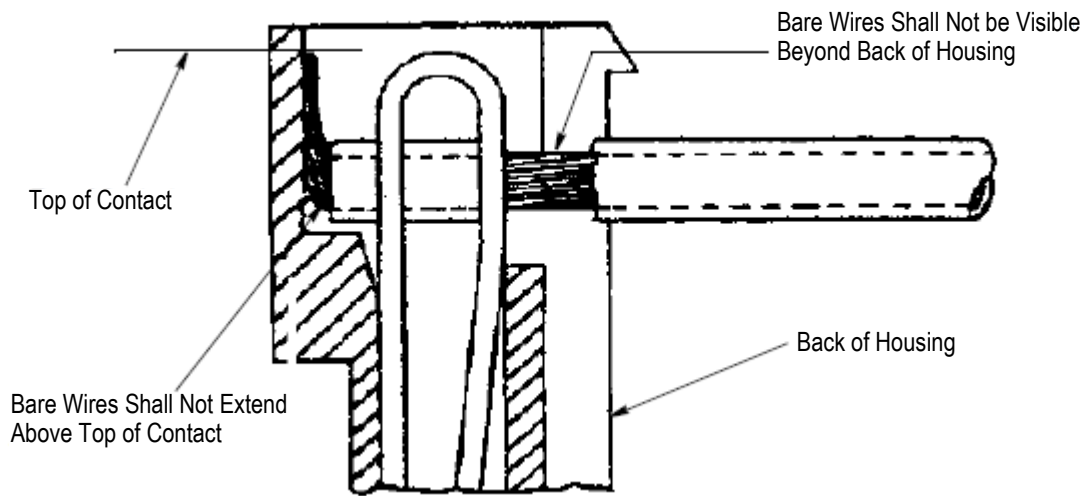

Figure 3

3.8. Conductor Insulation

Conductor insulation shall be contained within the confines of the insulation strain relief as indicated in Figure 4.

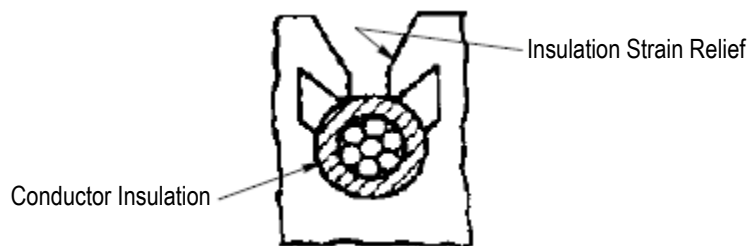

Figure 4

CONNECTOR ASSEMBLY PART NUMBERS†	WIRE SIZE (AWG)
640440	22
640441	24
640442	26
640443	28

†For other connector styles and plating types, consult TE Engineering.

Figure 5

3.9. Header Application

Standard temperature headers are recommended for solder dip, hand solder, or concentrated heat applications. They are not recommended for applications requiring preheating of the assembly.

High temperature headers may be used in similar applications as standard temperature headers and are also recommended for wave solder and infrared reflow solder processes. Temperature ratings for high temperature headers are listed in Figure 6. For solderability and heat resistance requirements, see Product Specification 108-1050.

Position	Temperature Rating (maximum)
2P – 12P	280°C
13P – 18P	235°C

Figure 6: Temperature Rating of High Temperature Headers