

# HI-IMPACT™

Complete Communication Solution  
for Harsh Environments.

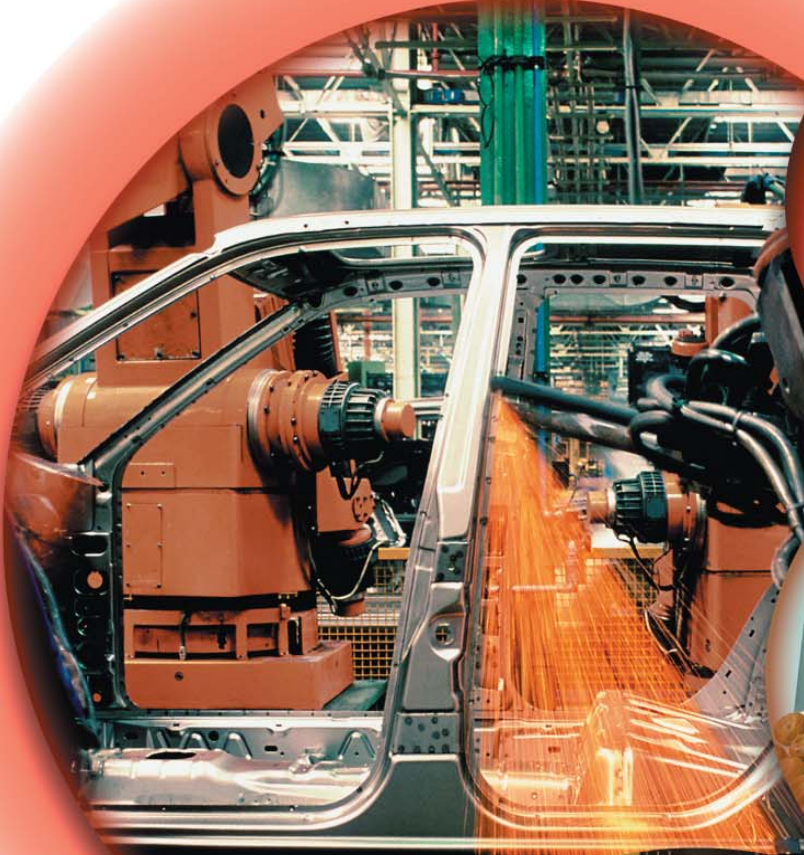

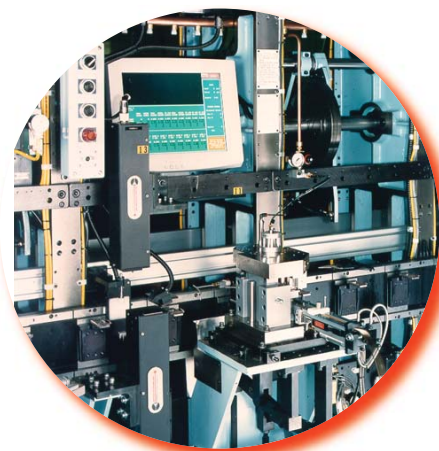
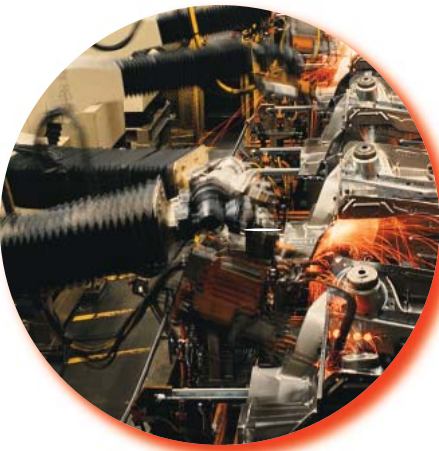

## From the most severe industrial to punishing commercial, HI-IMPACT™ System answers the call . . .

In today's competitive market the ability to access "Real Time" data is critical to customer satisfaction. "Real-Time" data supports the global trend of e-commerce, quick-response and vendor-managed inventory systems. Customers and suppliers now have the ability to look at all points in the supply chain, from raw material to finished goods. This ultimately improves responsiveness and provides a competitive edge to be best in class.

The global acceptance of Ethernet protocol has pushed RJ45 connectors from the corporate office to the more demanding industrial and harsh commercial environments. This trend has created the need for a more dynamic and robust solution. In these environments the typical mated connection may corrode, wear, clog with debris, and eventually fail. High maintenance costs, downtime and critical failure are the results, where dust, moisture, temperature extremes, EMI, and vibration are commonplace.

Hubbell's HI-IMPACT™ system is more than just a connection. It is a complete end-to-end communications solution designed to solve problems in the most severe industrial to punishing commercial environments.



## . . . Spanning applications from A to Z.

**Automated Tellers Machines**

**Billboards & Display**

**Educational**

K-12

University

**Entertainment & Hospitality**

Casinos

Convention Center

Entertainment

Fast Food

Hotels

Resorts

Restaurants

Stadiums

Theme Parks

**Food**

Commercial Kitchens

Fast Food Industry

Food Processing

**Geological Testing**

**Laboratories**

**Manufacturing**

Automation

Automotive

Finishing and Plating

Foundries

Material Handling

Molding

Paper Mills

Pharmaceutical

Process & Control

Robotics Welding

Stamping

Tool & Die

Warehouses

**Marinas**

**Medical**

Hospitals

Mobile Medical Units

**Military**

**Mining Industries**

**Oil Industries**

**Retail**

Supermarkets

**Transportation**

Airports

Bus Stations

Subways

Train Stations

**Utility Companies**

Electric Utilities

Refinement & Waste

Treatment facilities

**Vending Machines**

**Wireless**

**Zoos**

# HARSH-e A Comprehensive Rating System.

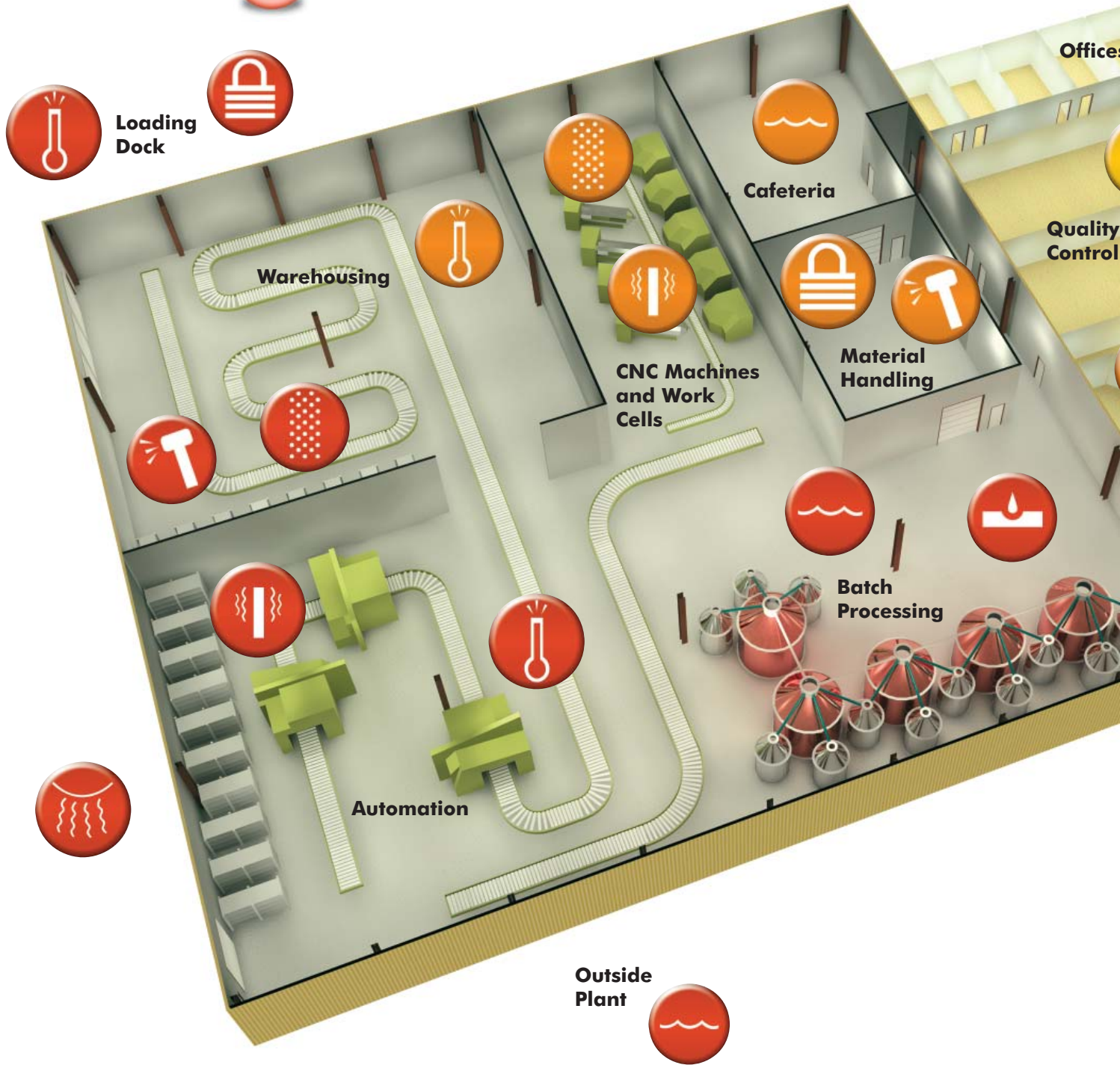





























The **H**ubbell **A**pplications **R**ating **S**ystem for **H**arsh **E**nvironments (HARSH-e) simplifies specifying the right product by categorizing environmental conditions into three classes – severe, harsh and tough.

For each environmental condition, identify the level that best describes your application in the HARSH-e table.

The most severe environmental condition dictates the HARSH-e level for your application.

See the page for the corresponding HARSH-e level for the product set and system components.

## HARSH- Hubbell Application Rating System for Harsh Environments

	 <b>e3 Application Severe</b>	 <b>e2 Application Harsh</b>	 <b>e1 Application Tough</b>
<b>Dust</b>	 Enclosures: <b>NEMA 4X</b> Connectors: <b>IP67</b> and <b>IP66</b> Totally protected against dust (Dust-tight)	 Enclosures: <b>NEMA 4/12/13</b> Connectors: <b>IP67</b> and <b>IP66</b> Protected against dust, Objects greater than 1 mm	 Enclosures: <b>NEMA 3R</b> Connectors: <b>IP43</b> Objects greater than 1 mm i.e., tools, wires, small wires
<b>Water</b>	 Enclosures: <b>NEMA 4X</b> Connectors: <b>IP67</b> and <b>IP66</b> Immersion and strong pressure jets	 Enclosures: <b>NEMA 4/12/13</b> Connectors: <b>IP67</b> and <b>IP66</b> Protected against strong and low pressure jets	 Enclosures: <b>NEMA 3R</b> Connectors: <b>IP43</b> Protected against sprays of water to 60° from vertical
<b>Corrosion</b>	 Enclosures: <b>NEMA 4X</b> Stainless Steel: Dust, water and corrosive liquids Connectors: PBT Common oils, chemicals and cleaning agents	 Enclosures: <b>NEMA 4/12/13</b> Ice, dust, water, non-corrosive liquids Connectors: PBT Common oils	 Enclosures: <b>NEMA 3R</b> Falling rain, sleet Connectors: N/A
<b>Impact</b>	 Enclosures: 14 ga., 304 SS Connector Housing: PBT	 Enclosures: 14 ga., steel Connector Housing: PBT	 Enclosures: 14 ga., steel Connectors: Thermoplastic
<b>Tamper</b>	 Enclosures: Protected, secured and locked	 Enclosures: Protected, and optional locked	 Enclosures: Protected, but not secured
<b>Temperature</b>	 TIA/EIA-568-B.2 TIA/TR 42.9 pending	 TIA/EIA-568-B.2	 TIA/EIA-568-B.2
<b>Vibration</b>	 TIA/TR 42.9 10-500Hz 5g Acceleration	 TIA/TR 42.9 10-500Hz 2g Acceleration	 TIA/TR 42.9 10-500Hz 0.7g Acceleration
<b>Ultra-Violet</b>	 Protected	 Protected	 Not Protected

# HI-IMPACT™

Connector Hardware for Harsh Environments.



**Vibration TIA-568-B.2**  
Transmission integrity



**O-Ring Seal**  
Reliable IP67 and IP66



**Maximum Cable Strain Relief**  
Resists pull-out

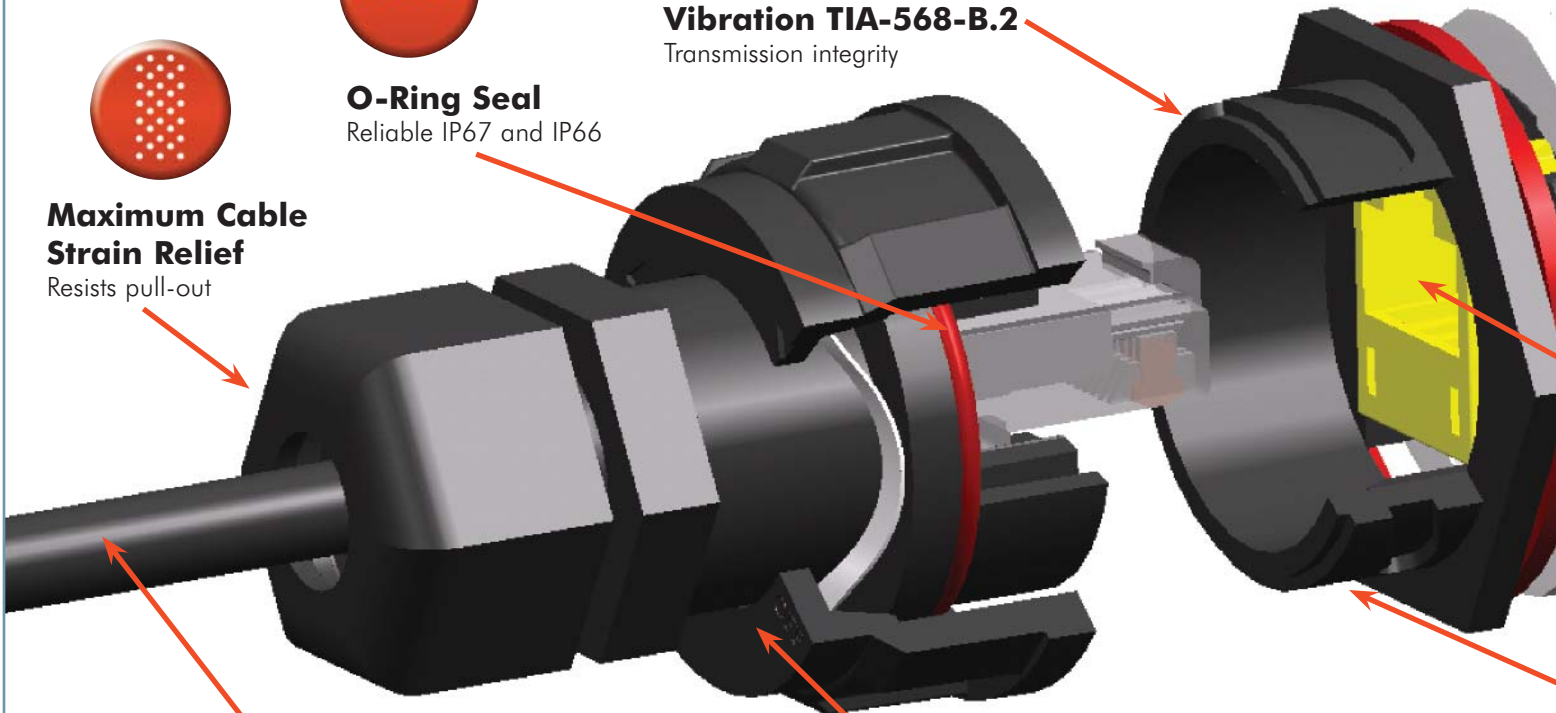

**Flexible Double Jacketed Patch Cable**  
Resistant to UV, chemicals, cleaning agents and oils



**PBT Construction**  
Resistant to temperature extremes and impact



**Connectors**



**Patch Cords**



**Plates**

**Standard 3/4" Knockout**  
Simplifies installation

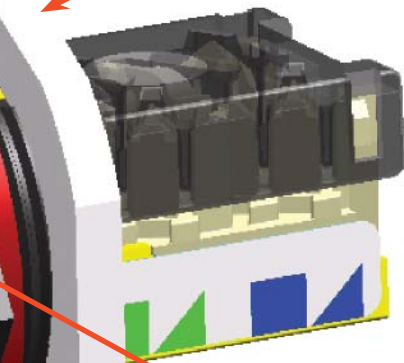

**Standard Hubbell Keystone Opening**  
Provides migration path

**User-Friendly Quick Connect**  
Positive indication when fully engaged



**Boxes**



**Cabinets**

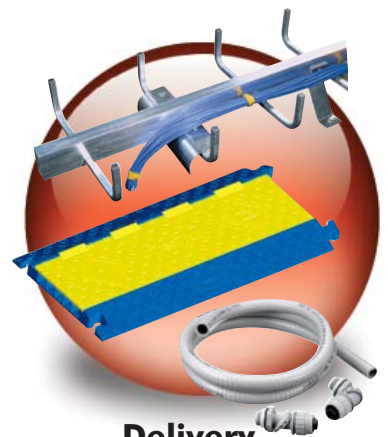

**Delivery**

**CONNECTOR SPECIFICATIONS**

**Environmental**

- Ingress Protection: IP67 and IP66 (dust and water)
- Corrosion: Resistant to most common chemicals, cleaning agents and oils
- UV: UV resistant (HI-IMPACT Housing)
- Temperature Range: TIA/EIA-568-B.2  
TIA/TR 42.9 (product pending)

**Mechanical**

- Vibration
  - Frequency Range: 10-500Hz
  - Acceleration: 5g
- Mating Cycles: 750 minimum
- UL 1863 listed

**Material**

- Connector Housing: PBT, UL94V-0
- Nose Contacts: Beryllium copper with a minimum of 50 micro-inch gold plating over nickel under plating
- IDC 110 Contacts: Phosphor bronze with 100 micro-inch tin lead 60/40 plating over nickel under plating

**Electrical**

- ANSI/TIA/EIA-568-B.2-1 (Category 6)
- ANSI/TIA/EIA-568-B.2 (Category 5e)
- Supports TIA/TR42.9 Industrial Draft
- Supports 4 times IEEE 802.3af DTE power specifications
- Exceeds IEEE 802.3ab Gigabit specifications to < 1 \* 10<sup>-13</sup>

**Certifications**

- UL Listed
- cUL Listed
- CSA Certified
- 3rd Party Verified Category 6 and 5e component





# 3 Severe Environments

HARSH-e3 applications are punishing environments where extreme temperatures, EMI, vibration and exposure to corrosive materials may be present.

## Typical Severe Environment Applications

- **Food Processing**
- **Manufacturing**
  - Automation
  - Automotive
  - Finishing and Plating
  - Foundries
  - Molding
  - Paper Mills
  - Process & Control
  - Robotics
  - Welding
  - Stamping
  - Tool & Die
- **Marinas**
- **Pharmaceutical**
- **Utility**
  - Electric Utilities
  - Oil & Mining Refinement & Waste Treatment Facilities



## HI-IMPACT™ Product Solutions



### Connectors

- Cat 5e
- Cat 5e Coupler
- \*F-Connector
- \*Cat 6
- \*M12



### Patch Cords

- Cat 5e
- Cat 6
- Hybrid Series
- M12 to RJ45



### Enclosures NEMA 4X

- REBox®
- Consolidation Point
- \*Wireless



### Plates and Boxes

- FS/FD Plates
- NEMA 4X Control Boxes
- Portable Outlet Boxes
- Weatherproof Box



### Delivery

- Center Rack
- TrukTrak®
- LiquidTight® Systems
- Cord Connectors





# 2 Harsh Environments

HARSH-e2 applications are harsh environments where hardware is exposed to regular abuse.

## Typical Harsh Environment Applications

- Automated Tellers Machines
- Billboards and Display
- Food
  - Commercial Food
  - Fast Food
  - Restaurants
- Laboratories
- Manufacturing
  - Automation
  - Material Handling
  - Warehouses
- Medical
  - Mobile Med Units
- Pharmaceutical
- Retail
- Transportation
  - Airports
  - Bus Stations
  - Subways
  - Train Stations
- Zoos

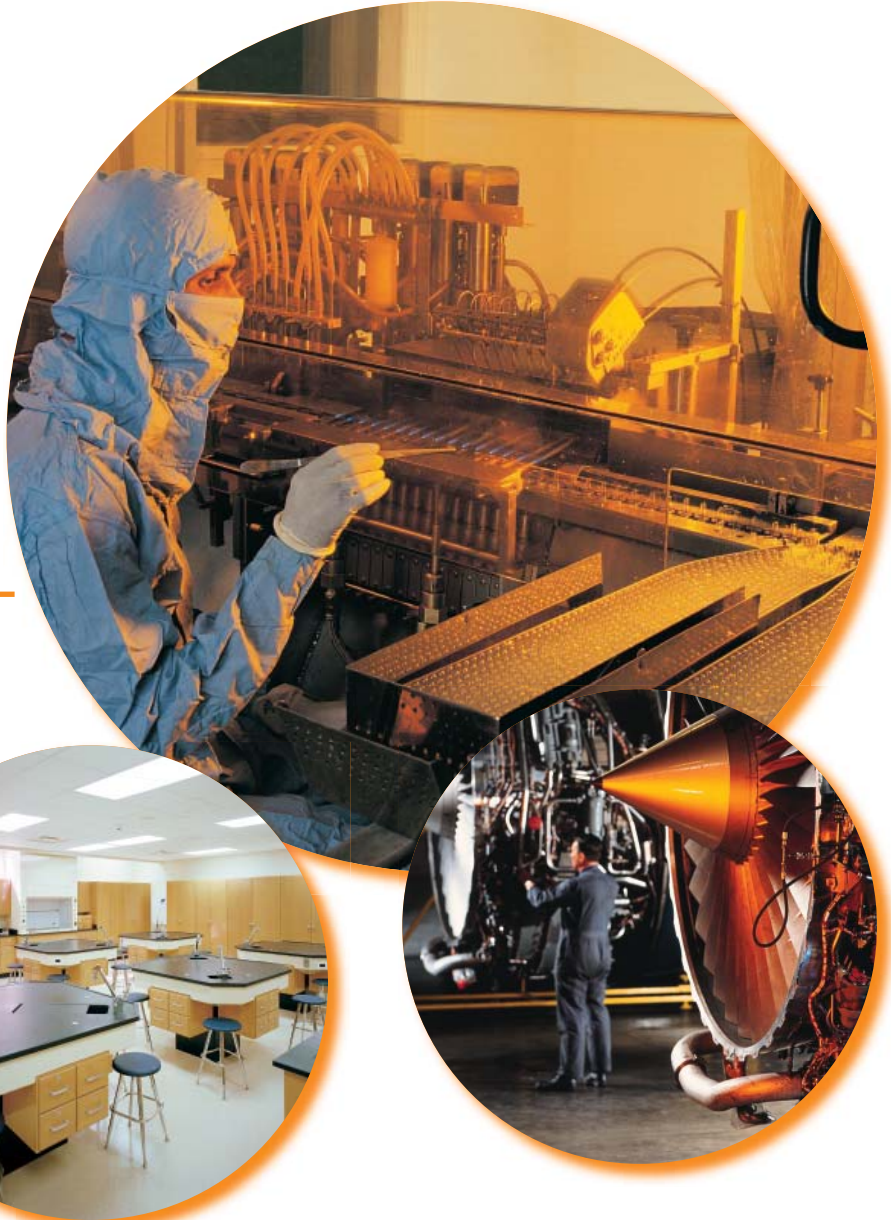

## HI-IMPACT™ Product Solutions



### Connectors

- Cat 5e
- Cat 5e Coupler
- \*F-Connector
- \*Cat 6



### Patch Cords

- Cat 5e
- Cat 6



### Enclosures NEMA 4/12/13

- REBox®
- Consolidation Point
- \*Wireless



### Plates and Boxes

- Plates
- NEMA 4/12/13 Control Boxes
- Portable Outlet Boxes
- Die-cast Box

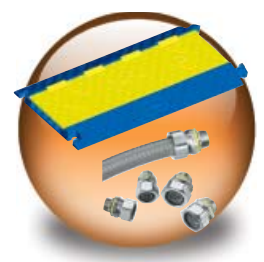

### Delivery

- Center Rack
- TredTrak®
- LiquidTight® Systems



# 1

# Tough Environments

HARSH-e1 applications are more demanding than typical commercial environments. Hardware is exposed to occasional rough use.

## Typical Tough Environment Applications

### ■ Hospitality and Entertainment

- Aquariums
- Amusement and Family Entertainment
- Casinos
- Convention Centers
- Hotels
- Resorts
- Stadiums
- Theme Parks

### ■ Educational

- K-12
- University

### ■ Grocery/Deli



## HI-IMPACT™ Product Solutions



### Connectors

- Cat 5e
- Cat 6
- Cat 5e Coupler



### Patch Cords

- Cat 5e
- Cat 6



### Enclosures NEMA 3R

- REBox®
- \*Wireless



### Plates and Boxes

- Communication Frames
- Flip Covers
- Bell® Boxes
- Work Boxes
- Secure-IT™ Plate



### Delivery

- Center Rack
- TredTrak®
- LiquidTight® Systems

# HARSH- A Comprehensive Rating System.

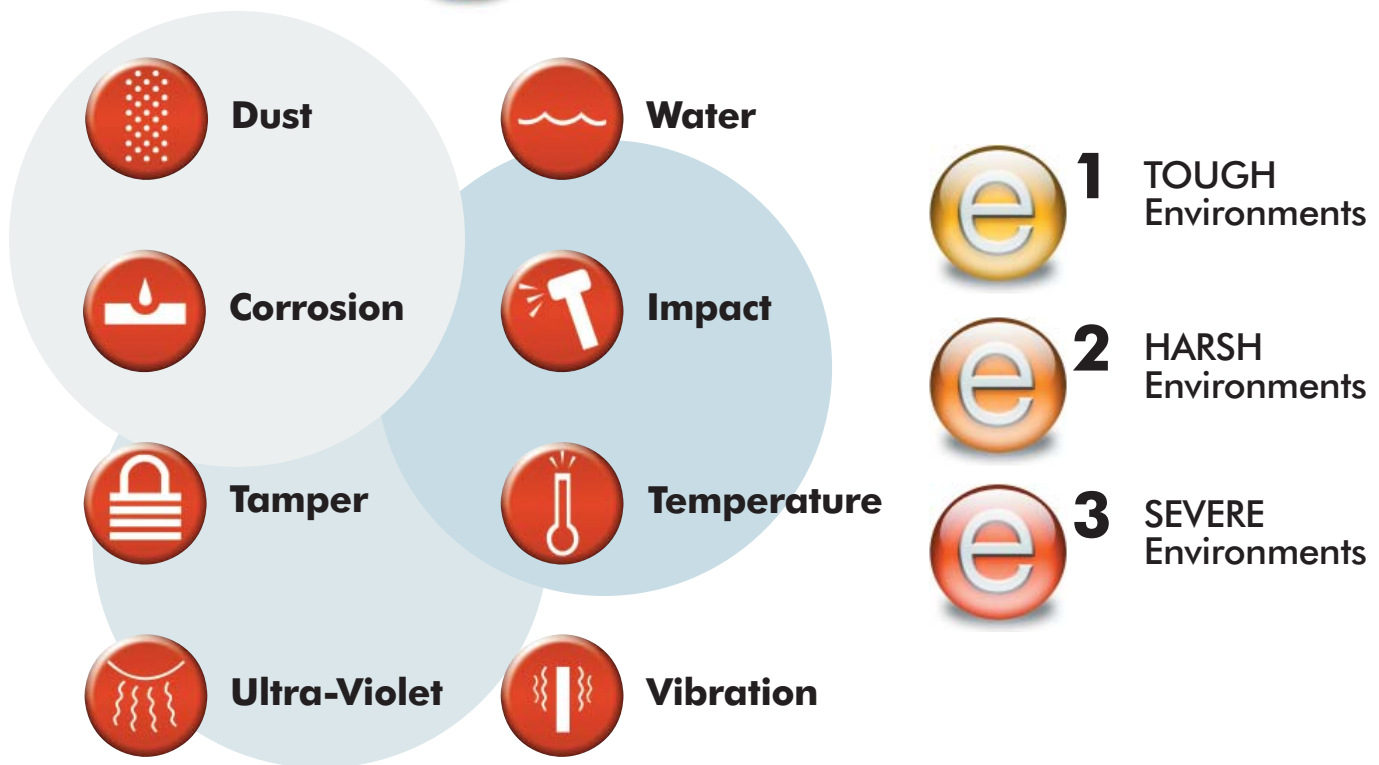



# Communication Solutions for Harsh Environments

# HI-IMPACT™

## HI-Impact™ Connectors

Call for additional product information



Type	Cat. No.
Cat 6	<b>HBLHI6*</b>
Cat 5e	<b>HBLHI5E</b>
Cat 5e In-Line Coupler	<b>HBLHI5EC</b>
Cat 5e Shielded	<b>HBLHI5ESC</b>
M12 MicroQuick, 4-position, Male	<b>MBMS14314</b>

\* Available Q2-2004.

## HI-Impact™ Plates

Call for additional product information

### Stainless Steel

Ports	Gang	Cat. No.
1	1	<b>HBLHISF11</b>
2	1	<b>HBLHISF12</b>
2	2	<b>HBLHISF22</b>
4	2	<b>HBLHISF24</b>



### Thermoplastic, 4-Point FS/FD, 1-Gang

Ports	Color	Cat. No.
1	Gray	<b>HBLHI14GY</b>
2	Gray	<b>HBLHI24GY</b>
1	Yellow	<b>HBLHI14PY</b>
2	Yellow	<b>HBLHI24PY</b>



## HI-Impact™ Boxes

Call for additional product information



### Fiberglass Weatherproof Device Box with Lugs

Knockout	Color	Cat. No.
3/4"	Yellow	<b>HBL60CM83</b>

### Cast Aluminum Device Box with Lugs

Knockout	Color	Cat. No.
1/2"	Gray	<b>HBLHIFD1L*</b>
3/4"	Gray	<b>HBLHIFD2L*</b>

\* Available Q2-2004.

## Communication Jacks



Description	Cat. No.
Category 6	<b>HBL6XX</b>
Category 5e	<b>HBL5EXX</b>

### XX = Color

<b>BK</b> = Black	<b>B</b> = Blue	<b>EI</b> = Electric Ivory
<b>GY</b> = Gray	<b>GN</b> = Green	<b>OW</b> = Office White
<b>OR</b> = Orange	<b>R</b> = Red	<b>TI</b> = Telco Ivory
<b>W</b> = White	<b>Y</b> = Yellow	

## Multimedia Connector

Description	Cat. No.
F-type	<b>HBLHIF**</b>

\*\* Available Q3-2004.



## Connector Cover

Description	Cat. No.
Protective Cover	<b>HBLHIC</b>



## Flip-Cover, Die-Cast Aluminum, Vertical, 1-Gang

Type	Cat. No.
Device	<b>WP26</b>
FS/FD	<b>WPFS26</b>



## Flip-Cover, Thermoplastic, Vertical, 1-Gang

Type	Cat. No.
Device	<b>HBL5222</b>
FS/FD	<b>HBL5221</b>



## Cast Aluminum Weatherproof Device Box with Lugs

Knockout	Color	Cat. No.
1/2"	Gray	<b>HBLHIWP05GY*</b>
3/4"	Gray	<b>HBLHIWP75GY*</b>

\* Available Q2-2004.

## NEMA 4X Box

Ports	Cat. No.
1	<b>HBLHI14XGY*</b>
2	<b>HBLHI24XGY*</b>
4	<b>HBLHI44XGY*</b>
6	<b>HBLHI64XGY*</b>



## Weatherproof, NEMA 3R

Horizontal	Gang	Cat. No.
Weatherproof	1	<b>WP826MHP</b>



Vertical	Gang	Cat. No.
Weatherproof	1	<b>WP826MP</b>
Weatherproof	2	<b>WP8262MP</b>



## Stainless Steel

Ports	Cat. No.
1	<b>HBLHI1CBSS*</b>
2	<b>HBLHI2CBSS*</b>

\* Available Q2-2004.



## HI-Impact™ Frames

Call for additional product information

### StyleLine® Frames

Ports	Cat. No.
2	<b>FCX244XX</b>
3	<b>FCX344XX</b>
4	<b>FCX444XX</b>
6	<b>FCX644XX</b>



### Duplex Frames

Ports	Cat. No.
2	<b>DJOXX</b>
4	<b>DJ106XX</b>



### xx = Color

<b>BK</b> = Black	<b>EI</b> = Electric Ivory
<b>GY</b> = Gray	<b>OW</b> = Office White
<b>W</b> = White	

Vertical	Gang	Cat. No.
Secure-IT™	1	<b>HBLTWP1GY</b>

## NEMA 4/12 Box

Stainless Steel, Gray	Port	Cat. No.
	1	<b>HBLHI1CBG*</b>
	2	<b>HBLHI2CBG*</b>

\* Available Q2-2004.



## Portable Outlet with Strain Relief Kit

Port	Cat. No.
1	<b>HBLHI1POB*</b>
Multiport	<b>HBLHIPOB*</b>

\* Available Q3-2004.

**HI-Impact™ Cords**  
Call for additional product information

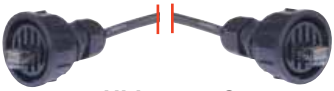

**HI-Impact to HI-Impact Connector**

Type	Cat. No.
Cat 6	<b>HBLHI6XXEE*</b>
Cat 5e	<b>HBLHI5EXXEE</b>
Cat 5e, Shielded	<b>HBLHI5ESXXEE**</b>
F-type	<b>HBLHIFXXEE**</b>
M12, 4-position female	<b>HBLHIM12XXEE**</b>



**HI-Impact Connector to RJ-45**

Type	Cat. No.
Cat 6	<b>HBLHI6XXAE*</b>
Cat 5e	<b>HBLHI5EXXAE</b>
Cat 5e, Shielded	<b>HBLHI5ESXXAE**</b>
F-type	<b>HBLHIFXXAE**</b>
M12, 4-position female	<b>HBLHIM12XXAE**</b>



**HI-Impact RJ-45 to RJ-45**

Type	Cat. No.
Cat 6	<b>HBLHI6XXAA*</b>
Cat 5e	<b>HBLHI5EXXAA</b>
Cat 5e, Shielded	<b>HBLHI5ESXXAA**</b>

**XX = Length**

<b>03</b> = 3'	<b>05</b> = 5'	<b>07</b> = 7'
<b>10</b> = 10'	<b>12</b> = 12'	<b>15</b> = 15'
<b>20</b> = 20'	<b>25</b> = 25'	

\* Available Q2-2004.

\*\* Available Q3-2004.

**HI-Impact™ Plugs and Cable**  
Call for additional product information

Type	Cat. No.
Cat 5e Plug	<b>HBLHI5EP</b>
Cat 5e Patch Cable, 100'	<b>HBLHIPC100</b>
F-type Connector	<b>HBLHIFP**</b>
RG-59 Patch Cable, 100'	<b>HBLHIFC100**</b>

\*\* Available Q3-2004.

**HI-Impact™ Cord Connectors & Grips**  
Call for additional product information



**Cord Connectors, 0.250" - 0.375"**

Description	Cat. No.
SS, 1/2"	<b>SHC1022SS</b>
Aluminum, 1/2"	<b>SHC1022</b>
Aluminum, 3/4"	<b>SHC1032</b>
Nylon, Gray, 3/4"	<b>SHC1022CR</b>

**Deluxe Cord Connectors, 0.250" - 0.375"**

Description	Cat. No.
SS, 1/2"	<b>07401006</b>
SS, 3/4"	<b>07401013</b>
Aluminum, 1/2"	<b>CG406NM</b>
Nylon, Gray, 1/2"	<b>074011332</b>

**HI-Impact™ Enclosures**  
Call for additional product information



**REBOX® NEMA 4/12/13, Gray**

Height	Type	Cat. No.
24"	Unloaded	<b>HBLIR2UG</b>
36"	Unloaded	<b>HBLIR3UG</b>
48"	Unloaded	<b>HBLIR4UG</b>
36"	Loaded	<b>HBLIR3PG</b>
48"	Loaded	<b>HBLIR4PG</b>

**REBOX® NEMA 4X, Stainless Steel**

Height	Type	Cat. No.
24"	Unloaded	<b>HBLIR2USS*</b>
36"	Unloaded	<b>HBLIR3USS*</b>

**REBOX® NEMA 3R, Gray**

Height	Type	Cat. No.
24"	Unloaded	<b>HBLIR2U2R</b>
36"	Unloaded	<b>HBLIR2U3R</b>

**REBOX® Accessories**

Description	Cat. No.
Plywood Backboard 20"H x 19"W	<b>HBLREKBB20</b>
30"H x 19"W	<b>HBLREKBB30</b>
40"H x 19"W	<b>HBLREKBB40</b>
Equipment Mounting Bracket, 5U	<b>HBLREKZ</b>
110/66 Block Mounting Rails (accepts five 100-pair/110-pair blocks)	<b>HBLREK110</b>
Patch Panel Bracket Bottom-hinged, 4U	<b>HBLREK19</b>
Fiber Patch Panel Bracket (accepts 1 FSP panel)	<b>HBLREKFP</b>
Economy Power Supply Kit, 15A	<b>HBLREKP</b>

**DIN Rail Utility Box, Duplex**



Description	Cat. No.
15A/5A Breaker	<b>DRUBTVSS15</b>
Duplex, Comm., 2-port	<b>HBLHIDRUBC2**</b>
Duplex, Comm., 4-port	<b>HBLHIDRUBC4**</b>

\*\* Available Q3-2004.

**Consolidation Point**



Type	Size	Cat. No.
SS	NEMA 4X	<b>HBLHICPSS*</b>
Gray	NEMA 4/12	<b>HBLHICP412G*</b>

\* Available Q2-2004.

**HI-Impact™ Delivery**  
Call for additional product information

**PolyTuff Conduit**



Size	Feet	Cat. No.
1/2"	100	<b>G1050</b>
3/4"	100	<b>G1075</b>

**LiquidTight, Metallic Fittings**



Size	Fitting Type	Cat. No.
1/2"	Straight Male	<b>H0501A</b>
3/4"	Straight Male	<b>H0751A</b>

**LiquidTight, Non-Metallic Fittings**



Size	Fitting Type	Cat. No.
1/2"	Straight Male	<b>P050NGYA</b>
3/4"	Straight Male	<b>P075NGYA</b>
1/2"	SwivelLok® Male	<b>PS0509NGY</b>
3/4"	SwivelLok® Male	<b>PS0759NGY</b>

**TredTrak, 5-Channel**

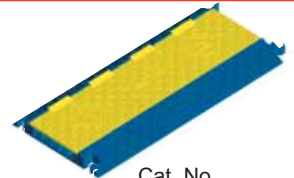

Description	Cat. No.
Track, 3' Section	<b>HBLTRED5B</b>
End Caps	<b>HBLTRED5ECB</b>
"X" Section	<b>HBLTRED5XB</b>
"Y" Section	<b>HBLTRED5YB</b>

**TrukTrak, 5-Channel**



Description	Cat. No.
Track, 3' Section	<b>HBLTT5B</b>
End Caps	<b>HBLTT5ECB</b>
Right Turn	<b>HBLTT545RB</b>
Left Turn	<b>HBLTT545LB</b>

H5148LC 03/04



© Hubbell Wiring Device-Kellems  
Hubbell Incorporated (Delaware)  
1-203-882-4800  
www.hubbell-wiring.com

[www.hubbell-solutions.com/Hi-Impact](http://www.hubbell-solutions.com/Hi-Impact)

# Find out more about your Hubbell HI-IMPACT™ Solution.



**HUBBELL**  
Wiring Devices & Systems  
KELLEMS Wire Management  
Marine Wiring Products

115  
YEARS

www.hubbell-wiring.com

Welcome to **Hubbell Wiring Device-Kellems**

For Over 100 Years an Innovative Market Leader in the Electrical Industry

- About Us
- What's New
- Contact Us
- Products & Applications
- Technical Help
- Trade Events
- Hubbell
- Distributor Search
- World Wide Offices
- Hubbell FAQ's
- Product Selectors
- Divisions & Subsidiaries
- Library & Catalogs
- National

**HUBBELL PREMISE WIRING**  
*The performance connection*

Full Line Catalog

Hubbell-Advantage.com  
The Performance Connection

Sales Offices / Distributors • Company Information • Upcoming Events • Press Room • Hubbell Merchandise • Contact Us

Catalogs | Customer Support Center | Training Programs | Mission Critical Warranty | Labeling | Timeline | Site Map

Keyword Part Number

**HUBBELL ADVANTAGE**

Support

- Online Catalog
- PDF Print Catalogs
- Product Datasheets
- Technical Index
- Tom's Tips
- Product Spotlight

Not a MEMBER yet?  
**HUB'S CLUB**  
Hubbell User Group  
Log in for Spec Text  
AutoCAD, Visio,  
Webinars and more

Breaking News

- New! I-Frame**  
Hubbell's new iFRAME combines cable management, racking, grounding, and power distribution functions into one simple, strong structural system.
- Raised Access Floor Boxes**  
Hubbell's new multi-service APB Series recessed stainless steel boxes are suitable for the majority of standard raised floor applications.

Featured

**Online Presentation**  
**Grounding and Bonding with Robert Baxter**  
Review the TIA 607 standard and applicable NEC articles. Discuss practical applications and why providing a proper ground system is so important for the safety and operation of today's network.



Hubbell Wiring Device-Kellems  
Hubbell Incorporated (Delaware)  
185 Plains Road  
Milford, CT 06460-2420  
Tel: (203) 882-4800  
Fax: (800) 255-1031  
www.hubbell-wiring.com  
**H5148** 03/04



Hubbell Premise Wiring  
Hubbell Incorporated (Delaware)  
14 Lord's Hill Road  
Stonington, CT 06378-0901  
Tel: (800) 626-0005  
Fax: (860) 535-8328  
www.hubbell-premise.com  
**B-HI6** 03/04