



7/16 COAXIAL CONNECTORS

Connex 7/16 series connectors provide superior performance for both return loss and intermodulation distortion. These connectors are ideal for those applications where vibration resistance and environmental protection is important, such as radio base stations and broadcast communication applications.

Connectors are 50 ohm impedance with standard M 29 x 1.5 metric threaded coupling. Designed to conform to the DIN standards, featuring excellent power-handling capability and low VSWR up to 7.5 GHz.

Nexcote, our trade name for the popular white bronze plating, is available upon request. Just add "NEX" to end of part number.

ELECTRICAL SPECIFICATIONS

Impedance	50 ohm
Frequency range	0–7.5 GHz
Working Voltage	2700 VRMS maximum at sea level
Dielectric Withstanding Voltage	4000 VRMS minimum at sea level
VSWR	Straight: 1.3 maximum Right Angle: 1.5 maximum
Contact resistance	Center Contact: 0.4 milliohms maximum Outer Contact: 0.2 milliohms maximum
Insulation resistance	5000 Megohms minimum

MATERIAL SPECIFICATIONS

PARTS NAME		MATERIAL	FINISH
Body metal parts		Brass per QQ-B-626	Silver
Contacts	Male	Brass per QQ-B-626	Silver
	Female	Beryllium copper per QQ-C-530	Silver
Insulator		PTFE	None
Gasket		Silicone rubber	None
Crimp ferrule		Annealed copper	Silver

Note: Other materials/finishes are available on request.

MECHANICAL SPECIFICATIONS

Coupling nut retention	225 lbs. maximum
Coupling proof torque	310 in-lbs. maximum
Contact retention	45 lbs. minimum
Durability (mating)	500 cycles minimum (for beryllium copper female contact only)



7/16 COAXIAL CONNECTORS

INTERFACE MATING DIMENSIONS

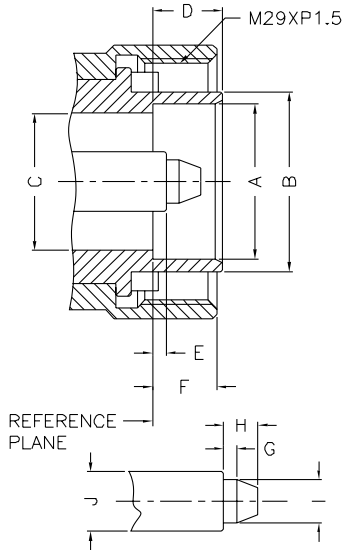

PLUG

Letter	Millimeters [Inches]	
	Minimum	Maximum
A	18.03 [.710]	18.21 [.717]
B	20.60 [.812]	21.40 [.843]
C	15.85 [.624]	16.25 [.640]
D	7.00 [.276]	8.00 [.315]
E	1.47 [.058]	1.77 [.070]
F	7.00 [.276]	9.00 [.355]
G	1.40 [.055]	1.60 [.063]
H	–	4.50 [.177]
I	4.96 [.195]	5.04 [.199]
J	6.97 [.275]	7.03 [.277]

JACK

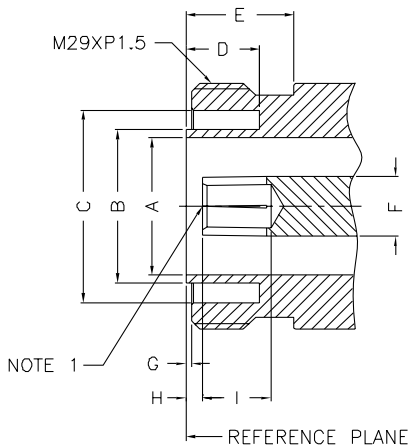

Letter	Millimeters [Inches]	
	Minimum	Maximum
A	15.85 [.624]	16.25 [.640]
B	–	18.00 [.709]
C	22.10 [.871]	22.90 [.902]
D	8.10 [.319]	–
E	10.00 [.394]	–
F	6.97 [.275]	7.03 [.277]
G	0.50 [.020]	0.70 [.028]
H	1.77 [.070]	2.07 [.082]
I	5.00 [.197]	–

NOTE 1: I.D. TO MEET VSWR AND CONTACT RESISTANCE WHEN MATED WITH 4.96/5.04 MM DIA. PIN.

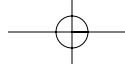

7/16 COAXIAL CONNECTORS

All connector bodies and center contacts, unless otherwise noted, are silver-plated with no nickel undercoat.

All dimensions are in millimeters [inches].

CABLE GROUP LEGEND

01	58/ 58A/ 58C/ 141/ 303/ LMR195™/ B7806A	06A	179/ U DOUBLE BRAIDED	09	B8227/ 89207
01A	55/ 142/ 223/ 400	07	8/ 8A/ 213/ 393	10	.141 SEMI-RIGID/ 402/U
01B	LMR200™/ B7807A	07A	214	11	.085 SEMI-RIGID/ 405/U
02	58 PLENUM/THINNET/ 122U/ B88240/ B89907	07B	8X/ LMR240™/ B7808A	12	.250 SEMI-RIGID
03	59/ 62/ 140/ 210	07C	B9913/ LMR400™/ B7810A/ B8214	13	.047 SEMI-RIGID/ B1674A
03A	59/ U-20AWG	07D	B89913	14	178/ 196
04	59/ U PLENUM	07E	11	15	B8281/ B9231/ B9141
04A	59/ U PLENUM-20AWG	07F	11/ U-14AWG/ B8213/ B9292/ B7731/ B1859A	15A	B88281
05	174/ 188A/ 316/ B7805A	08	6/ 143/ 212	16	180/ 195/ 122/ B8218/ B1865A/ B1855
05A	316/ U DOUBLE BRAIDED	08A	B1694A/ B9248	17	LMR600™
06	179/ 187/ B9221	08B	6 PLENUM/ B1695A	18	AT&T734A/ B1505A
				19	AT&T735A/ B735A1

7/16 STRAIGHT PLUGS

STRAIGHT CRIMP PLUG — FLEXIBLE CABLE

P.N.	Cable Group	Finish	Insulation	Impedance	Crimp Tool
272103	01	Silver	Teflon	50	A
272104	01A	Silver	Teflon	50	A
272172	05	Silver	Teflon	50	B
272105	07	Silver	Teflon	50	D
272106	07A	Silver	Teflon	50	D
272107	07C	Silver	Teflon	50	D
272108	17	Silver	Teflon	50	.610 HEX

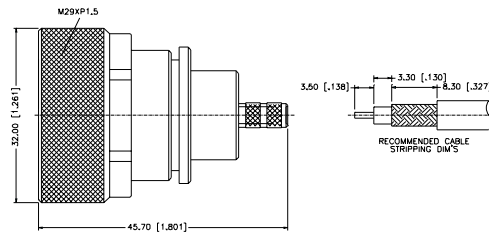
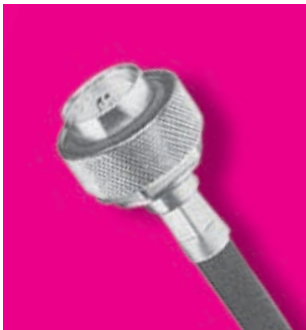

STRAIGHT SOLDER PLUG — SEMI-RIGID CABLE

P.N.	Cable Group	Finish	Insulation	Impedance	Crimp Tool
272109	10	Silver	Teflon	50	N/A
272163	11	Silver	Teflon	50	N/A
272110	12	Silver	Teflon	50	N/A

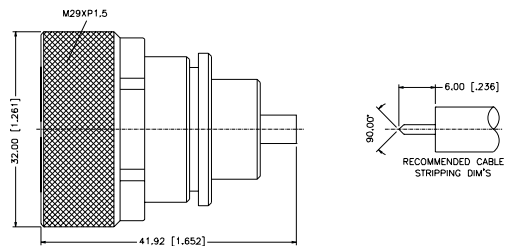

STRAIGHT CLAMP PLUG — SUPER FLEX CABLE

P.N.	Cable Group	Finish	Insulation	Impedance	Crimp Tool
272138	3/8" SUPER FLEX ANDREWS FSJ HELICAL	Silver	Teflon	50	N/A
272139	1/2" SUPER FLEX ANDREWS FSJ HELICAL	Silver	Teflon	50	N/A
272164	7/8" SUPER FLEX ANDREWS FSJ HELICAL	Silver	Teflon	50	N/A

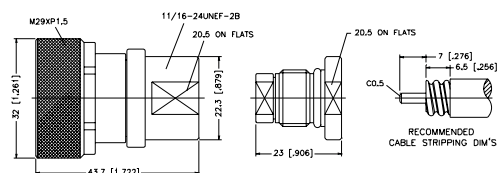

7/16 COAXIAL CONNECTORS

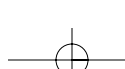

7/16 STRAIGHT PLUGS

For Cable Group Legend, see page 137

STRAIGHT PLUG — PRESS FIT

P.N.	Cable Group	Finish	Insulation	Impedance	Crimp Tool
272178	N/A	Silver	Teflon	50	N/A

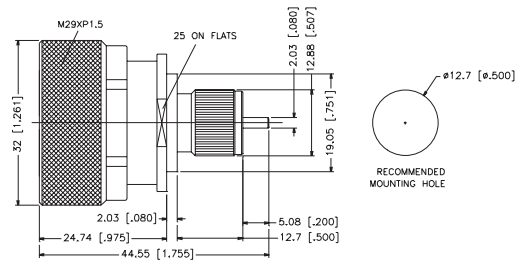

7/16 RIGHT ANGLE PLUGS

RIGHT ANGLE CRIMP PLUG — FLEXIBLE CABLE

P.N.	Cable Group	Finish	Insulation	Impedance	Crimp Tool
272111	01	Silver	Teflon	50	A
272112	01A	Silver	Teflon	50	A
272113	07	Silver	Teflon	50	D
272114	07A	Silver	Teflon	50	D
272115	07C	Silver	Teflon	50	D
272116	17	Silver	Teflon	50	.610 HEX

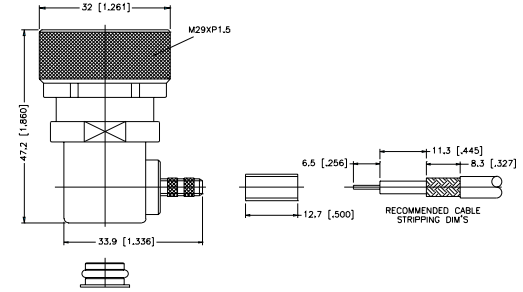

RIGHT ANGLE SOLDER PLUG — SEMI-RIGID CABLE

P.N.	Cable Group	Finish	Insulation	Impedance	Crimp Tool
272117	10	Silver	Teflon	50	N/A
272165	11	Silver	Teflon	50	N/A
272118	12	Silver	Teflon	50	N/A

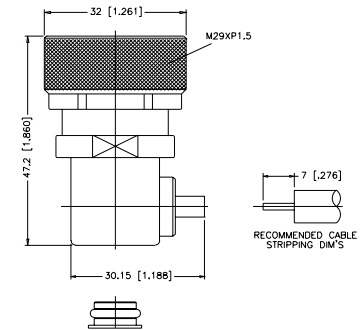

RIGHT ANGLE CLAMP PLUG — SUPER FLEX CABLE

P.N.	Cable Group	Finish	Insulation	Impedance	Crimp Tool
272136	3/8" SUPER FLEX	Silver	Teflon	50	N/A
272137	1/2" SUPER FLEX	Silver	Teflon	50	N/A
272166	7/8" HELICAL	Silver	Teflon	50	N/A

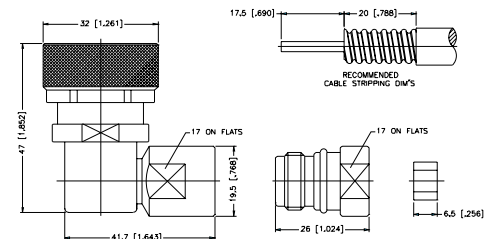

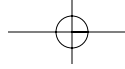

7/16 STRAIGHT JACKS

For Cable Group Legend, see page 137

STRAIGHT CRIMP JACK — FLEXIBLE CABLE

P.N.	Cable Group	Finish	Insulation	Impedance	Crimp Tool
272140	01	Silver	Teflon	50	A
272141	01A	Silver	Teflon	50	A
272142	07	Silver	Teflon	50	D
272143	07A	Silver	Teflon	50	D
272144	07C	Silver	Teflon	50	D
272145	17	Silver	Teflon	50	.610 HEX

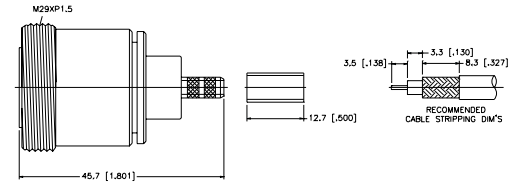
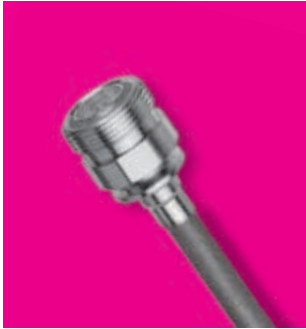

STRAIGHT SOLDER JACKS — SEMI-RIGID CABLE

P.N.	Cable Group	Finish	Insulation	Impedance	Crimp Tool
272146	10	Silver	Teflon	50	N/A
272167	11	Silver	Teflon	50	N/A
272147	12	Silver	Teflon	50	N/A

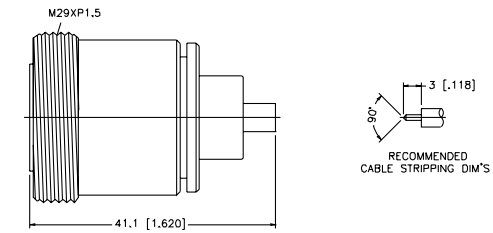

STRAIGHT CLAMP JACK — SUPER FLEX CABLE

P.N.	Cable Group	Finish	Insulation	Impedance	Crimp Tool
272148	3/8" SUPER FLEX	Silver	Teflon	50	N/A
272149	1/2" SUPER FLEX	Silver	Teflon	50	N/A
272168	7/8" HELICAL	Silver	Teflon	50	N/A

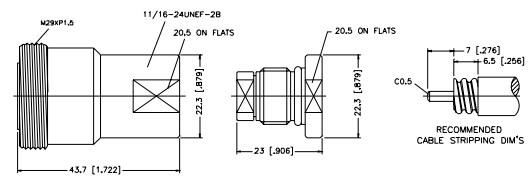

STRAIGHT JACK — PRESS FIT

P.N.	Cable Group	Finish	Insulation	Impedance	Crimp Tool
272179	N/A	Silver	Teflon	50	N/A

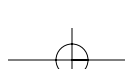
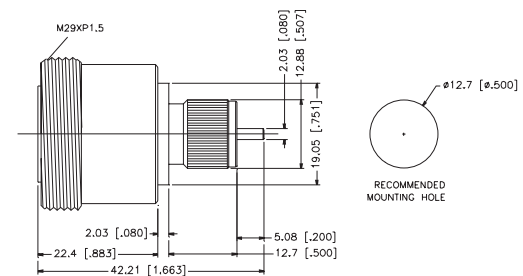

7/16 PANEL JACKS

For Cable Group Legend, see page 137

PANEL CRIMP JACK — FLEXIBLE CABLE

P.N.	Cable Group	Finish	Insulation	Impedance	Crimp Tool
272119	01	Silver	Teflon	50	A
272120	01A	Silver	Teflon	50	A
272121	07	Silver	Teflon	50	D
272122	07A	Silver	Teflon	50	D
272123	07C	Silver	Teflon	50	D
272124	17	Silver	Teflon	50	.610 HEX

Remark: For O-ring gasket, add -10 to part number

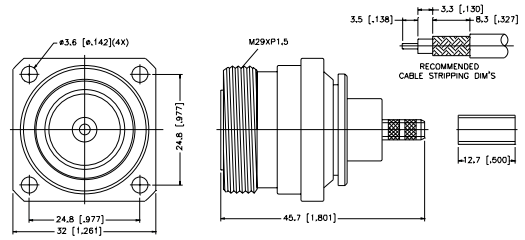
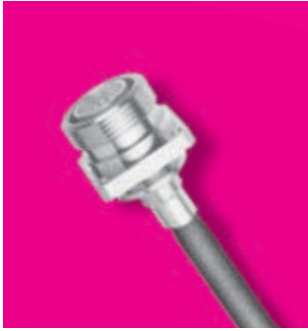

PANEL SOLDER JACK — SEMI-RIGID CABLE

P.N.	Cable Group	Finish	Insulation	Impedance	Crimp Tool
272100	10	Silver	Teflon	50	N/A
272169	11	Silver	Teflon	50	N/A
272101	12	Silver	Teflon	50	N/A

Remark: For O-ring gasket, add -10 to part number



272100

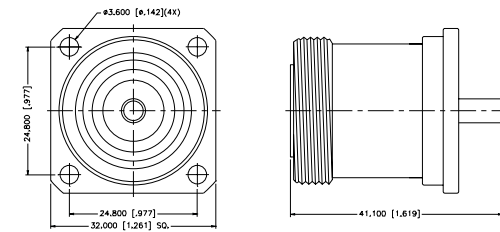

272100-10

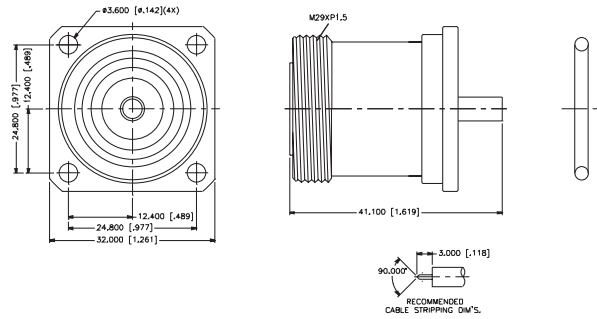

PANEL CLAMP JACK — SUPER FLEX CABLE

P.N.	Cable Group	Finish	Insulation	Impedance	Crimp Tool
272128	3/8" SUPER FLEX	Silver	Teflon	50	N/A
272129	1/2" SUPER FLEX	Silver	Teflon	50	N/A

Remark: For O-ring gasket, add -10 to part number

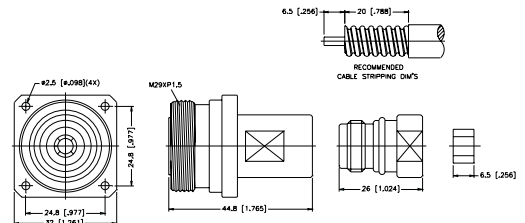

7/16 BULKHEAD JACKS

For Cable Group Legend, see page 137

BULKHEAD CRIMP JACK — FLEXIBLE CABLE

P.N.	Cable Group	Finish	Insulation	Impedance	Crimp Tool
272151	01	Silver	Teflon	50	A
272152	01A	Silver	Teflon	50	A
272153	07	Silver	Teflon	50	D
272154	07A	Silver	Teflon	50	D
272155	07C	Silver	Teflon	50	D
272156	17	Silver	Teflon	50	.610 HEX

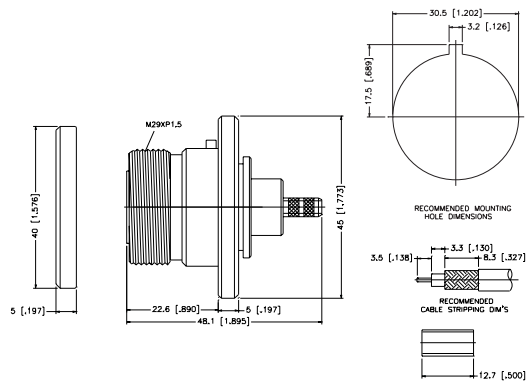

BULKHEAD SOLDER JACK — SEMI-RIGID CABLE

P.N.	Cable Group	Finish	Insulation	Impedance	Crimp Tool
272158	10	Silver	Teflon	50	N/A
272157	11	Silver	Teflon	50	N/A
272159	12	Silver	Teflon	50	N/A

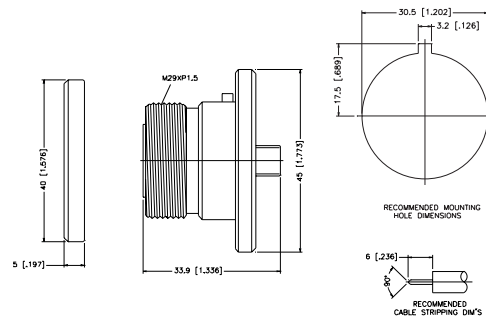

BULKHEAD CLAMP JACK — CORRUGATED CABLE

P.N.	Cable Group	Finish	Insulation	Impedance	Crimp Tool
272160	3/8" SUPER FLEX	Silver	Teflon	50	N/A
272161	1/2" SUPER FLEX	Silver	Teflon	50	N/A
272162	7/8" HELICAL	Silver	Teflon	50	N/A

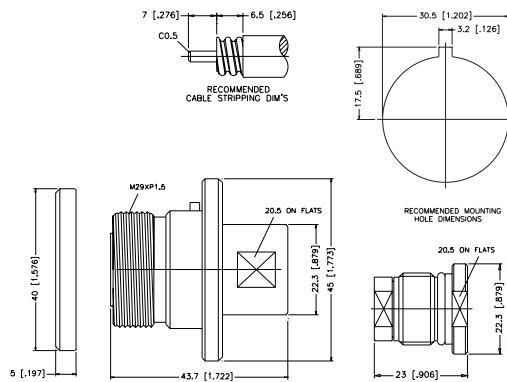

7/16 PANEL RECEPTACLES

For Cable Group Legend, see page 137

PANEL JACK RECEPTACLES

P.N.	Cable Group	Finish	Insulation	Impedance	Crimp Tool
272130	N/A	Silver SOLDER CONTACT	Teflon	50	N/A
272131	N/A	Silver THREADED CONTACT	Teflon	50	N/A
272173	N/A	Silver SOLDER CONTACT, 1 INCH FLANGE	Teflon	50	N/A

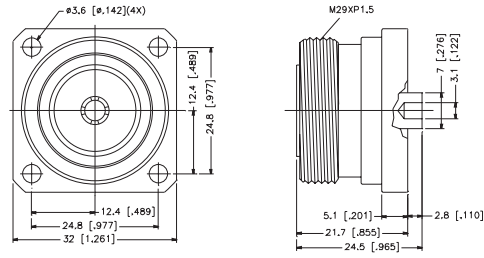

PANEL PLUG RECEPTACLES

P.N.	Cable Group	Finish	Insulation	Impedance	Crimp Tool
272132	N/A	Silver SOLDER CONTACT	Teflon	50	N/A
272133	N/A	Silver THREADED CONTACT	Teflon	50	N/A

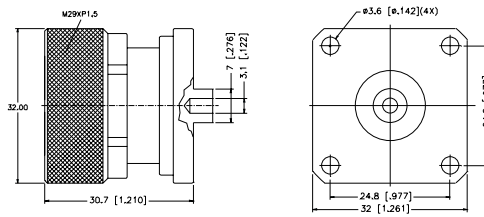

BULKHEAD RECEPTACLES

P.N.	Cable Group	Finish	Insulation	Impedance	Crimp Tool
272171	N/A	Silver	Teflon	50	N/A

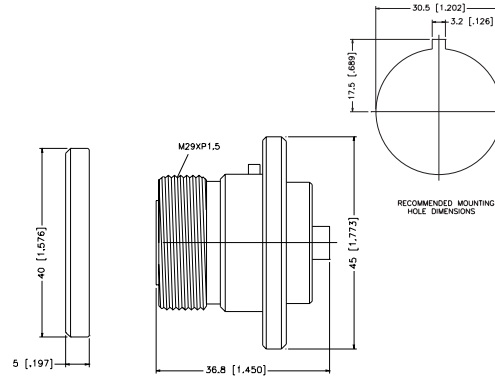

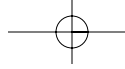

7/16 ADAPTERS

For Cable Group Legend, see page 137

PLUG-TO-PLUG ADAPTER

P.N.	Cable Group	Finish	Insulation	Impedance	Crimp Tool
272134	N/A	Silver	Teflon	50	N/A

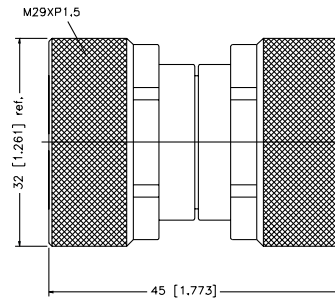

JACK-TO-JACK ADAPTER

P.N.	Cable Group	Finish	Insulation	Impedance	Crimp Tool
272135	N/A	Silver	Teflon	50	N/A

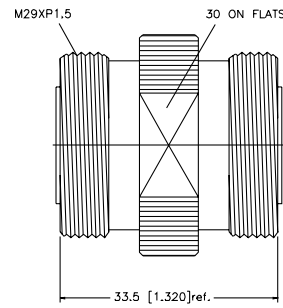

RIGHT ANGLE PLUG-TO-JACK ADAPTER

P.N.	Cable Group	Finish	Insulation	Impedance	Crimp Tool
272150	N/A	Silver	Teflon	50	N/A

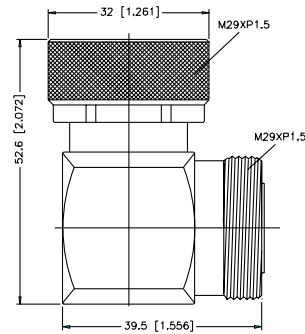

JACK-TO-JACK BULKHEAD ADAPTER

P.N.	Cable Group	Finish	Insulation	Impedance	Crimp Tool
272174	N/A	Silver	Teflon	50	N/A

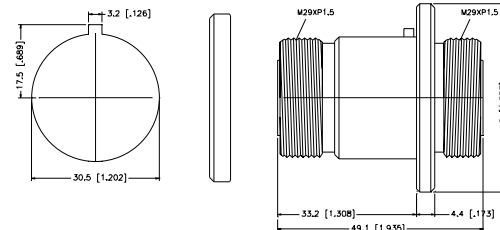

For Crimp Tool information, see page 183.

