

Motorized Standard Surface Electric Scissor Lift Desktop Sit-Stand Workstation

pro-SIGNAL



Description

Sit-stand workstations are the easiest and the most versatile method to convert any desk to sit-stand desks. Best of all, there is no need to replace existing furniture and desks—simply unbox and place the workstations on the desktop. 50-25005 even makes the easy products easier. Powerful motor lifts heavy load on work surface with a touch of button. The motor driven mode avoids the awkward forward posture while lifting regular workstation—the posture increases the heavy load on lumbar area. Quiet motion prevents interrupting the working environment. Sophisticated motion control generates smooth and stable adjustment.

Features

- Strong motor ensures a very high stability level
- Easy-to-Use press controller makes height adjustment easy
- Spacious surface for placing more devices
- Cable management keeps everything organized

Specifications

Type	: Tabletop Workstation, Premium
Material	: Plastic, MDF & PVC, Steel
Colour	: Brown Desktop with Black Base, Black, White
Dimensions	: 950mm × 621mm × 156mm ~ 485mm (37.4" × 24.4" × 6.1" ~ 19.1")
Work Surface Size (L × W)	: 950mm × 400mm (37.4" × 15.7")
Tabletop Thickness	: 15mm (0.59")
Height Range	: 156mm ~ 485mm (6.1" ~ 19.1")
Height Adjustment	: Electric
Power Input	: 100 - 240V
Work Surface Weight Capacity	: 20kg (44lbs)
Keyboard Weight Capacity	: 2kg (4.4lbs)
Installation	: Tabletop Stand

Accessories

Normal / Zip lock Polybag, Power Plug & Instruction Manual.

Diagram

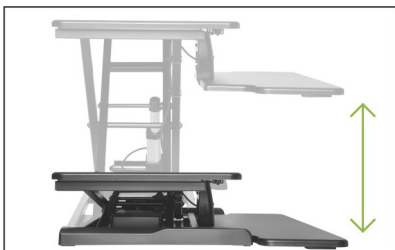

Height Adjustment
Accommodate most users



Open Storage Slot
For tablets or phones



Powerful Motor
Allows for stable height adjustment

Motorized Standard Surface Electric Scissor Lift Desktop Sit-Stand Workstation

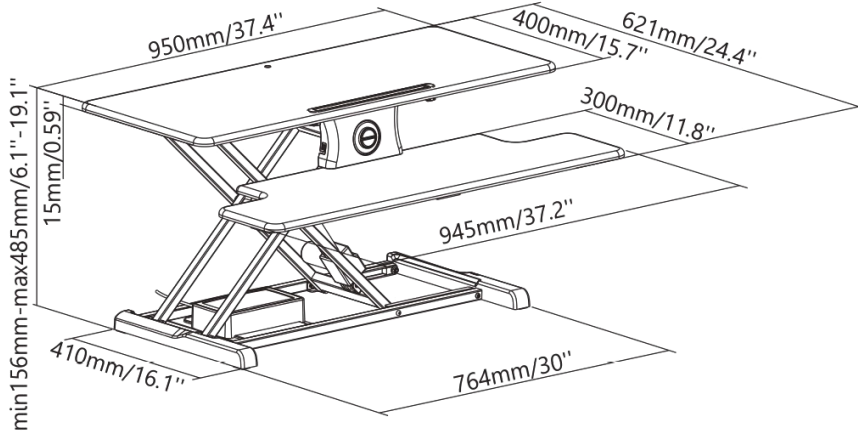

Dimensions : Millimetres (Inches)

Part Number Table

Description	Part Number
Motorized Standard Surface Electric Scissor Lift Desktop Sit-Stand Workstation	50-25005

Important Notice : This data sheet and its contents (the "Information") belong to the members of the Premier Farnell group of companies (the "Group") or are licensed to it. No licence is granted for the use of it other than for information purposes in connection with the products to which it relates. No licence of any intellectual property rights is granted. The Information is subject to change without notice and replaces all data sheets previously supplied. The Information supplied is believed to be accurate but the Group assumes no responsibility for its accuracy or completeness, any error in or omission from it or for any use made of it. Users of this data sheet should check for themselves the Information and the suitability of the products for their purpose and not make any assumptions based on information included or omitted. Liability for loss or damage resulting from any reliance on the Information or use of it (including liability resulting from negligence or where the Group was aware of the possibility of such loss or damage arising) is excluded. This will not operate to limit or restrict the Group's liability for death or personal injury resulting from its negligence. pro-SIGNAL is the registered trademark of the Group. © Premier Farnell Limited 2016.

