

HPF-18-01-T-S

HPF-10-02-T-S

**HPF SERIES**

(5,08 mm) .200"

# POWER SOCKETS

## SPECIFICATIONS

For complete specifications and recommended PCB layouts see [www.samtec.com?HPF](http://www.samtec.com?HPF)

**Insulator Material:**

Black LCP

**Contact Material:**

BeCu

**Plating:**

Sn over

50µ" (1,27 µm) Ni

**Insertion Depth:**

(3,68 mm) .145" to (8,26 mm) .325" (.368" (9,35 mm) plus board thickness minimum for bottom entry)

**Wiping Distance:**

(0,38 mm) .015"

**Insertion Force:**

(Single contact only)

56 oz (15,57 N) avg.

**Withdrawal Force:**

(Single contact only)

52 oz (14,46 N) avg.

**Lead-Free Solderable:**

Yes

**SMT Lead Coplanarity:**

(0,15 mm) .006" max (02-10)

(0,20 mm) .008" max (11-20)

**RoHS Compliant:**

Yes

Mates with:  
HPM, HPW

**POWER EYE CONTACT**



HPF/HPM	
PINS	CURRENT RATING (PER CONTACT)
1	16.6 A
2	14.4 A
3	13.2 A
4	12.7 A
ALL	8.9 A

Surface Mount or Through-hole

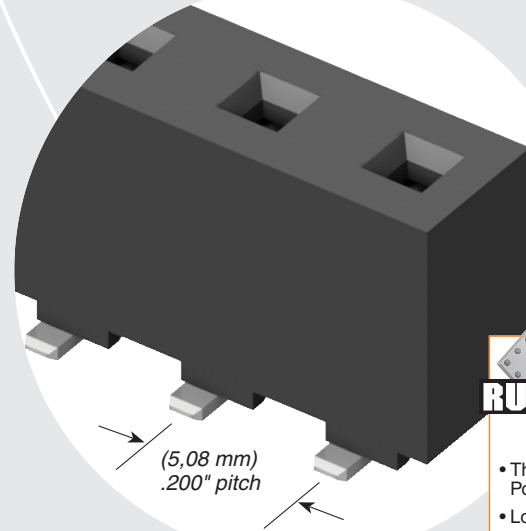

(5,08 mm) .200" pitch

**RUGGEDIZED**  
by SAMTEC

- Three-finger Power Eye contact
- Locking clip option

## RECOGNITIONS

For complete scope of recognitions see [www.samtec.com/quality](http://www.samtec.com/quality)



<b>HPF</b>	<b>NO. PINS PER ROW</b>	<b>LEAD STYLE</b>	<b>PLATING OPTION</b>	<b>S</b>	<b>OTHER OPTIONS</b>
	<b>02 thru 20</b>	<b>-01</b> = Through-hole	<b>-T</b> = Matte Tin		<b>-LC</b> = Locking Clip (Manual placement required) (Style -02 only)
		<b>-02</b> = Surface Mount			<b>-K</b> = (6,50 mm) .256" DIA Polyimide Film Pick & Place Pad
					<b>-TR</b> = Tape & Reel Packaging (14 positions maximum) (Style -02 only)

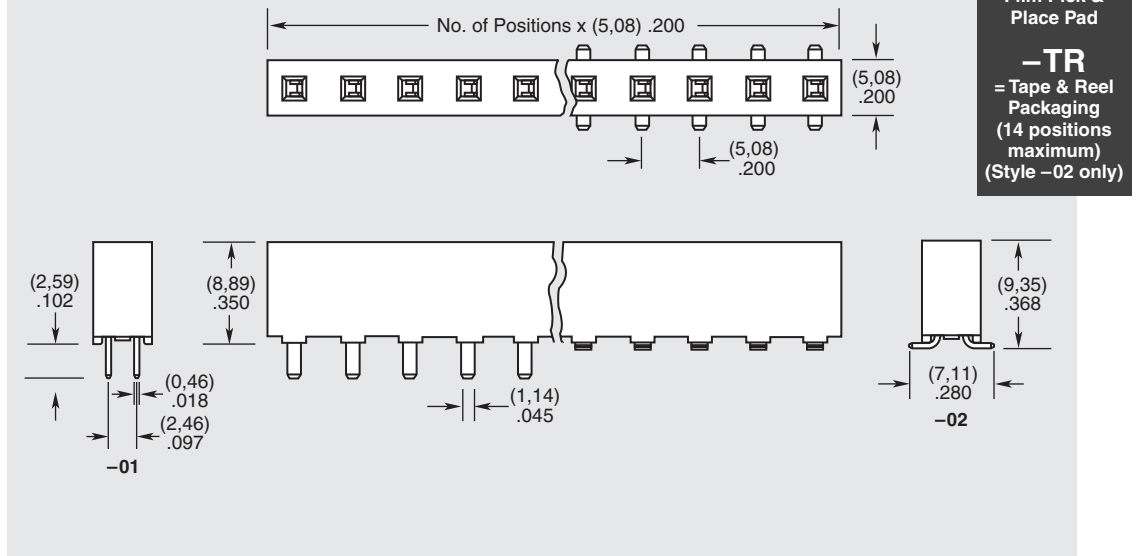

**Note:** Some lengths, styles and options are non-standard, non-returnable.