



NOTE

All numerical values are in metric units [with U.S. customary units in brackets]. Dimensions are in millimeters. Unless otherwise specified, dimensions have a tolerance of ± 0.13 and angles have a tolerance of $\pm 2^\circ$. Figures and illustrations are for identification only and are not drawn to scale.

1. INTRODUCTION

This specification covers the requirements for application of the single port and ganged OSFP cage assemblies utilized to interconnect OSFP fiber optic or copper transceiver modules to host printed circuit boards. The OSFP cage assembly is a pre-assembled unit available in a 1X1 and 1X4 configurations. Product styles include iterations that contain bezel EMI springs or no EMI springs. In addition, light pipe kits for each configuration are available.

The cage assembly features compliant pin contacts for mechanical retention to the pc board and to provide EMI suppression. It also features thermal vent holes, and either EMI springs or no EMI springs. In addition, the cage assembly ports contain latch tabs used to retain the transceiver modules during operation. A dust cover for each port may be used when a module is not mated to the cage assembly to prevent contaminants from entering the chassis. Alternatively, an EMI plug is available for each empty port to prevent EMI leakage. The cage assembly is designed to be inserted thru a bezel after being seated on the pc board.

The cage is used in conjunction with a 60 position SMT OSFP receptacle, which is soldered to the pc board before the cage is pressed on.

When corresponding with TE Connectivity Personnel, use the terminology provided in this specification to facilitate your inquiries for information. Basic terms and features of this product are provided in Figure 1.

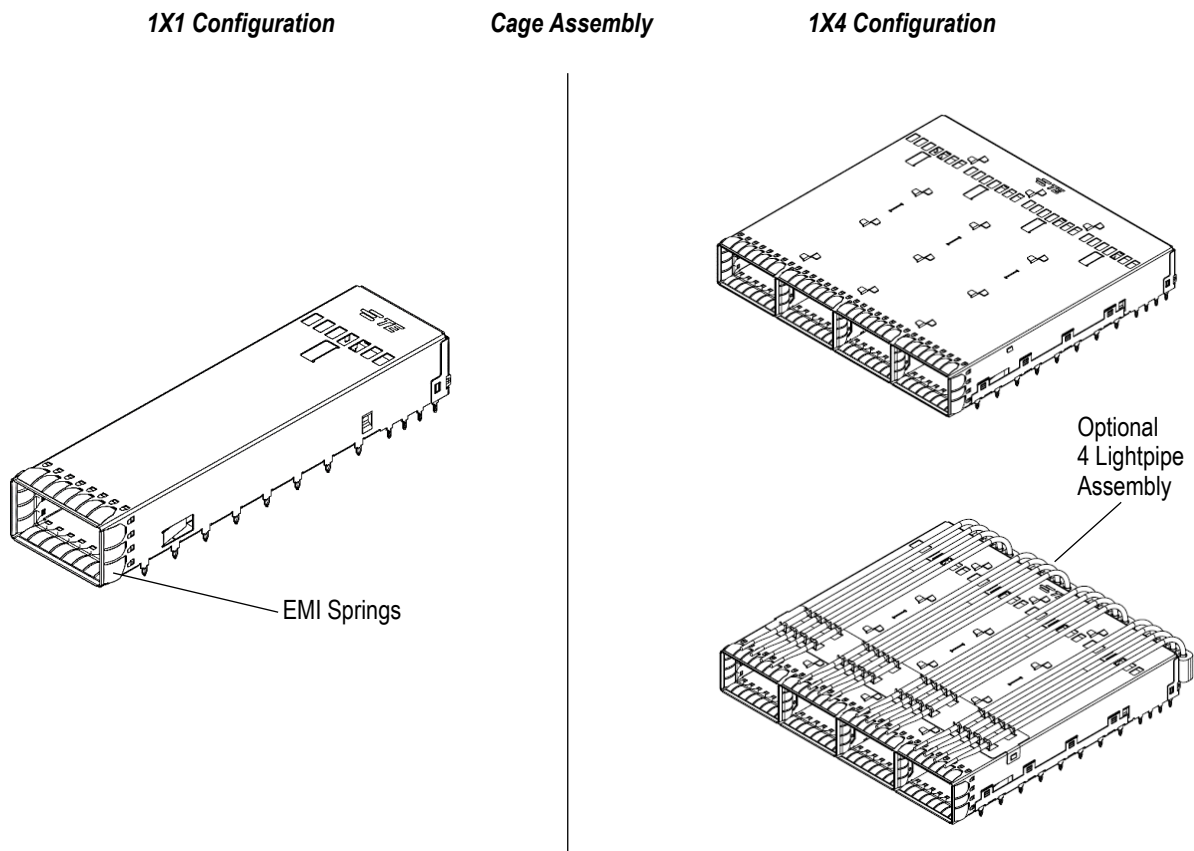

Figure 1 (cont'd)

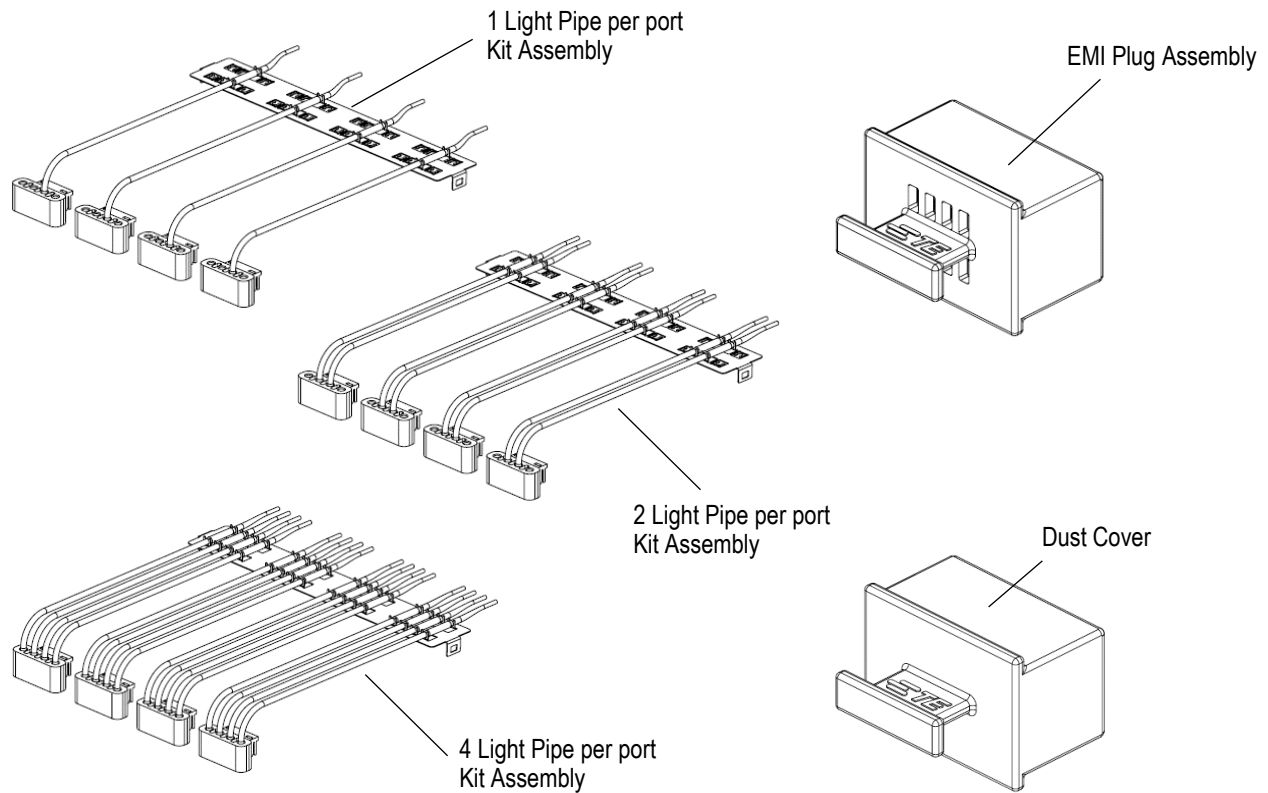

Figure 1 (end)

2. REFERENCE MATERIAL

2.1. Revision Summary

Initial release of application specification

2.2. Customer Assistance

Reference Product Base Part Numbers 2317416 (1X1), 2315853 (1X4), 2317857 (EMI Plug), 2324698 (Dust Cover) and Product Code X600 are representative of the OSFP single port and ganged Cage Assemblies. Use of these numbers will identify the product line and help you to obtain product and tooling information when visiting www.te.com or calling the number at the bottom of page 1.

2.3. Drawings

Customer drawings for product part numbers are available from www.te.com. Information contained in the customer drawing takes priority.

2.4. Specifications

Product Specification 108-60117 provides product performance and test results.

2.5. Instructional Material

Instruction sheets (408-series) provide product assembly instructions or tooling setup and operation procedures. Instructional material that pertains to this product are:

408-xxxx OSFP 1xN Cage Assembly Extraction Tools

3. REQUIREMENTS

3.1. Safety

Do not stack product shipping containers so high that the containers buckle or deform.

3.2. Storage

A. Ultraviolet Light

Prolonged exposure to ultraviolet light may deteriorate the chemical composition used in the product material.

B. Shelf Life

The product should remain in the shipping containers until ready for use to prevent deformation to components. The product should be used on a first in, first out basis to avoid storage contamination that could adversely affect performance.

C. Chemical Exposure

Do not store product near any chemical listed below as they may cause stress corrosion cracking in the material.

Alkalies	Ammonia	Citrates	Phosphates	Citrates	Sulfur Compounds
Amines	Carbonates	Nitrites	Sulfur Nitrites		Tartrates

3.3. Limitations

The connectors are designed to operate in a temperature range of -55 to 85°C [-67 to 185°F].

The bezel requirements given in this document are specifically configured for products used in the communications industry, and peripheral component interconnect (PCI) applications.

3.4. Material

The cage components are made from a stainless steel alloy. The EMI springs are made from a copper alloy. The light pipe kits are made from molded polycarbonate material and stainless steel alloy.

3.5. PC Board

A. Material and Thickness

The pc board material shall be glassed epoxy (FR-4 or G10). The minimum pc board thickness shall be 1.50mm for single sided applications, 2.10mm for dual sided applications. These minimum thickness values include the board thicknesses tolerance.

B. Tolerance

Maximum allowable bow of the pc board shall be 0.08 mm over the length of the connector and cage assembly.

C. Hole Dimensions

The holes for the cage assembly must be drilled and plated through to dimensions specified in Figure 2.

D. Layout

The holes for the connector and cage assembly must be precisely located to ensure proper placement and optimum performance of the connector and cage assembly. Recommended hole pattern, dimensions, and tolerances are provided on the customer prints. Sample layouts are provided in Figures 3 through 7.

Recommended Hole Dimensions for Cage Assembly

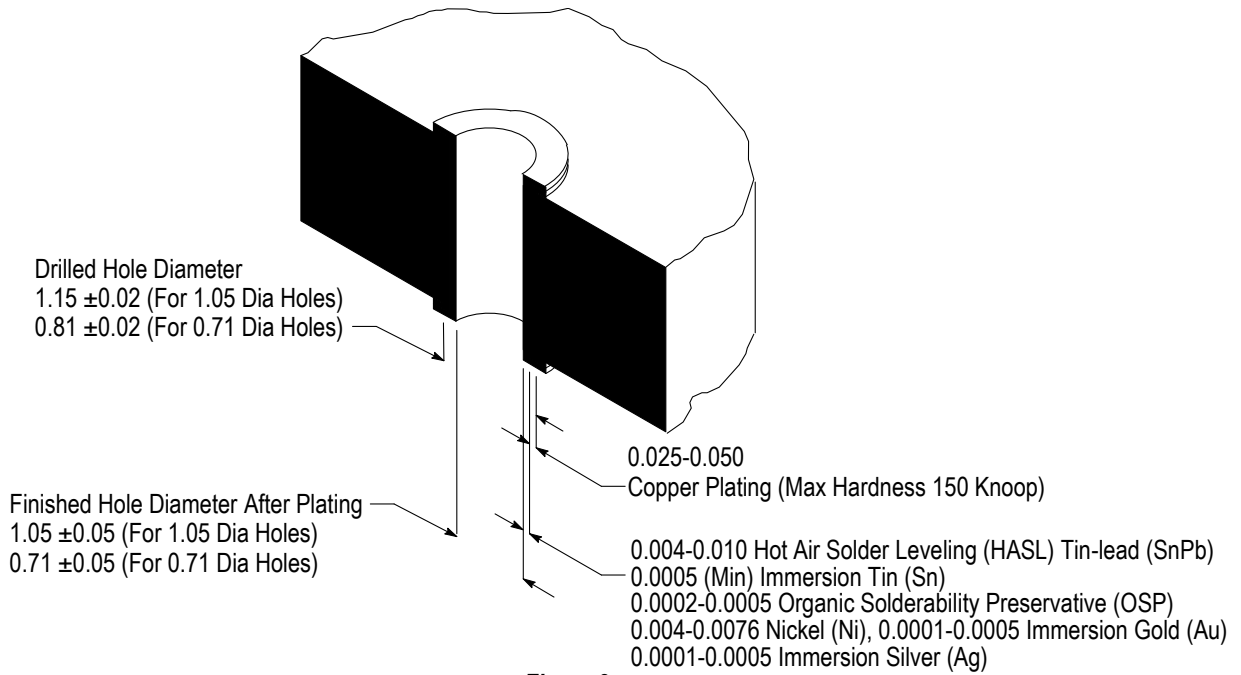

Figure 2

**Recommended PC Board Layout
 (SMT Connector)**

PIN #	DESCRIPTION	PIN #	DESCRIPTION	PIN #	DESCRIPTION
1	SIGNAL GROUND	21	SIGNAL GROUND	41	SIGNAL
2	SIGNAL	22	SIGNAL	42	SIGNAL
3	SIGNAL	23	SIGNAL	43	SIGNAL GROUND
4	SIGNAL GROUND	24	SIGNAL GROUND	44	AUX
5	SIGNAL	25	SIGNAL	45	AUX
6	SIGNAL	26	SIGNAL	46	AUX
7	SIGNAL GROUND	27	SIGNAL GROUND	47	AUX
8	SIGNAL	28	SIGNAL	48	SIGNAL GROUND
9	SIGNAL	29	SIGNAL	49	SIGNAL
10	SIGNAL GROUND	30	SIGNAL GROUND	50	SIGNAL
11	SIGNAL	31	SIGNAL GROUND	51	SIGNAL GROUND
12	SIGNAL	32	SIGNAL	52	SIGNAL
13	SIGNAL GROUND	33	SIGNAL	53	SIGNAL
14	AUX	34	SIGNAL GROUND	54	SIGNAL GROUND
15	AUX	35	SIGNAL	55	SIGNAL
16	AUX	36	SIGNAL	56	SIGNAL
17	AUX	37	SIGNAL GROUND	57	SIGNAL GROUND
18	SIGNAL GROUND	38	SIGNAL	58	SIGNAL
19	SIGNAL	39	SIGNAL	59	SIGNAL
20	SIGNAL	40	SIGNAL GROUND	60	SIGNAL GROUND

Figure 3 (Cont'd)

**Recommended PC Board Layout
(SMT Connector)**

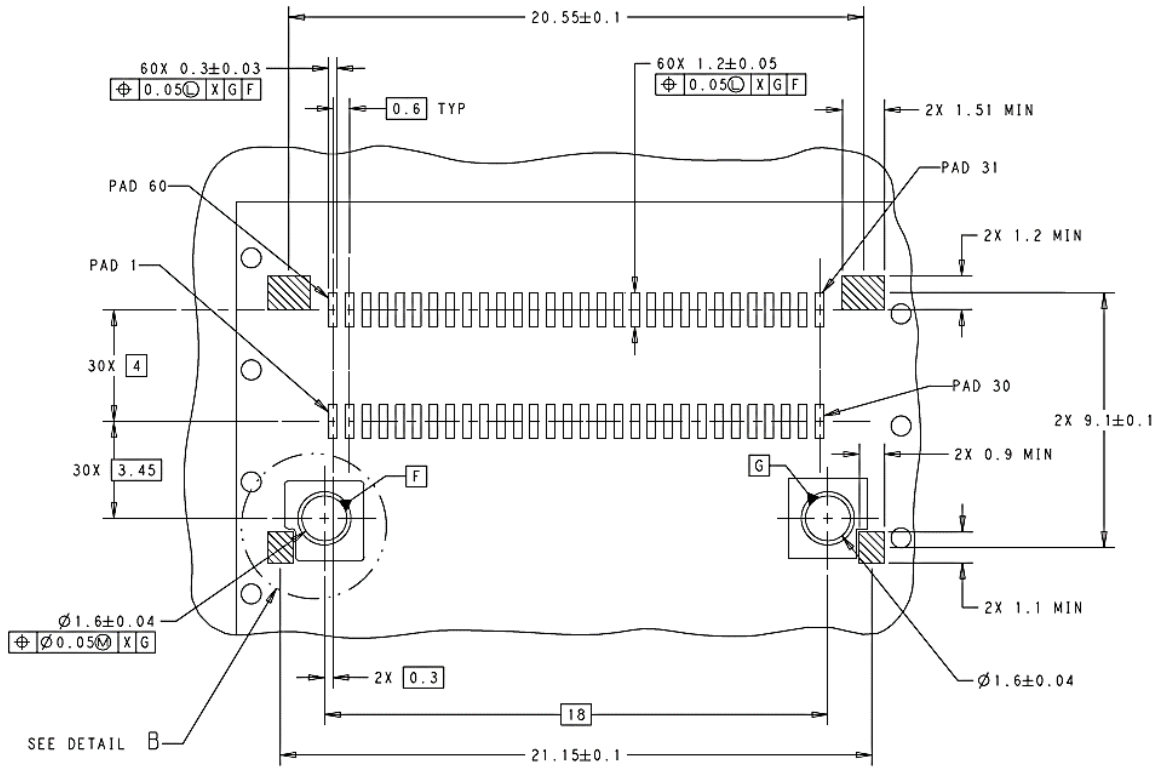

Detail A

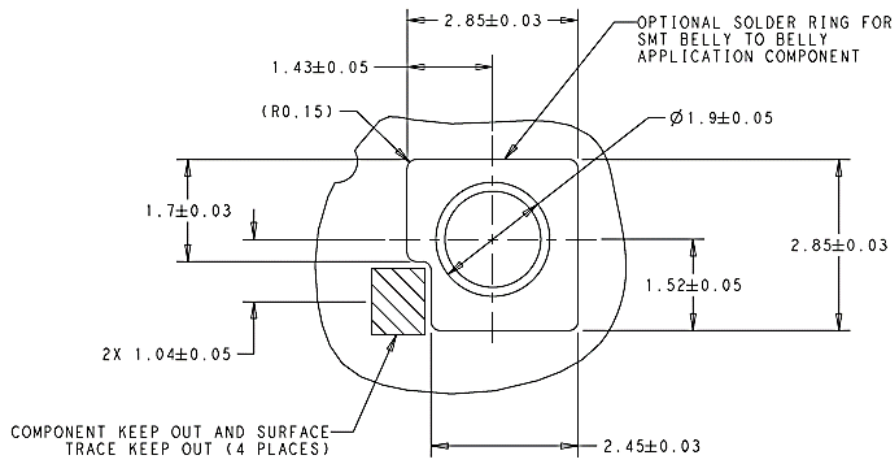

Detail B

Figure 3 (end)

Recommended PC Board Layout
(1x1 Cage Assembly Single Sided Configuration)

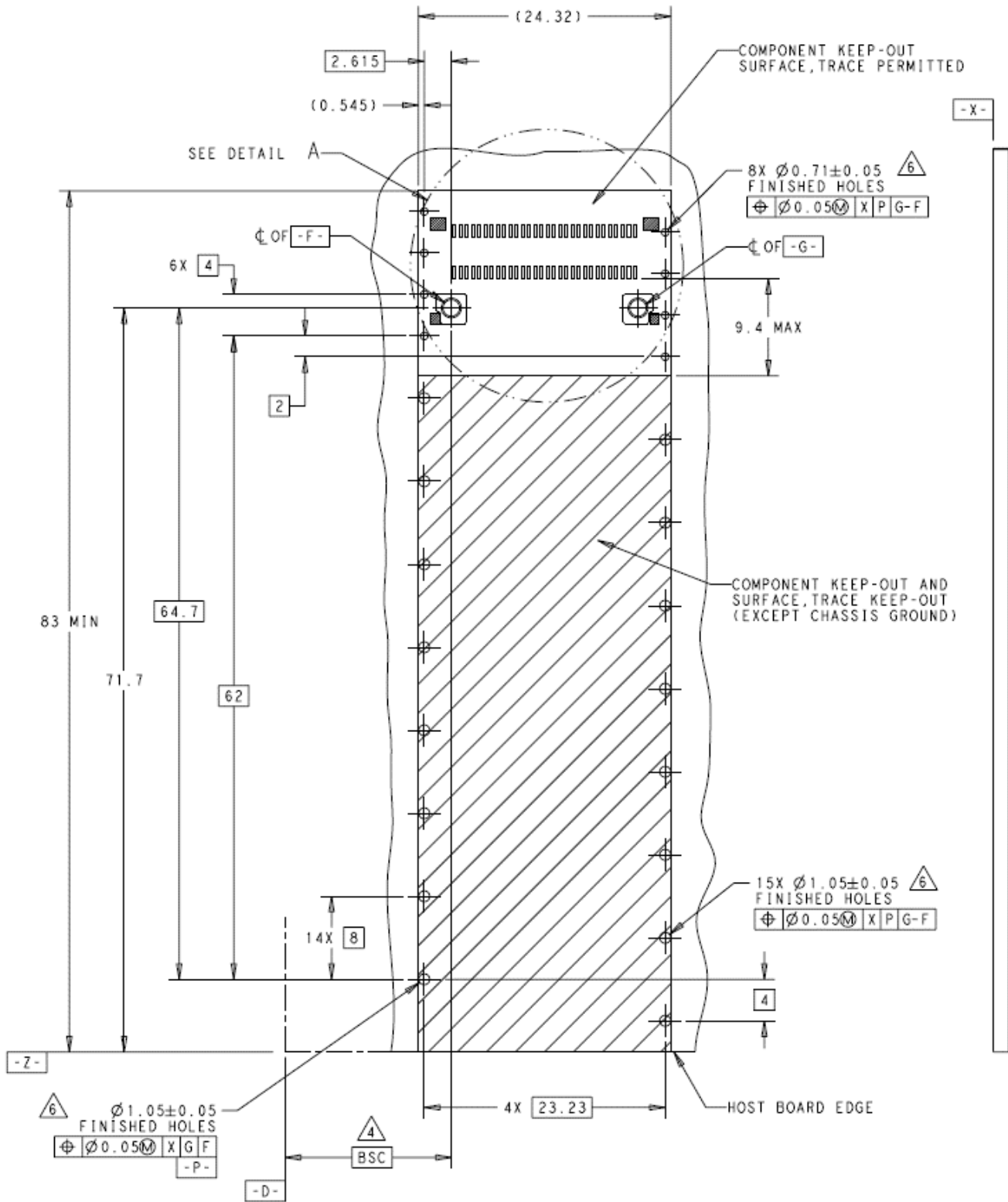

Figure 4

Recommended PC Board Layout
(1x1 Cage Assembly Belly to Belly Configuration)

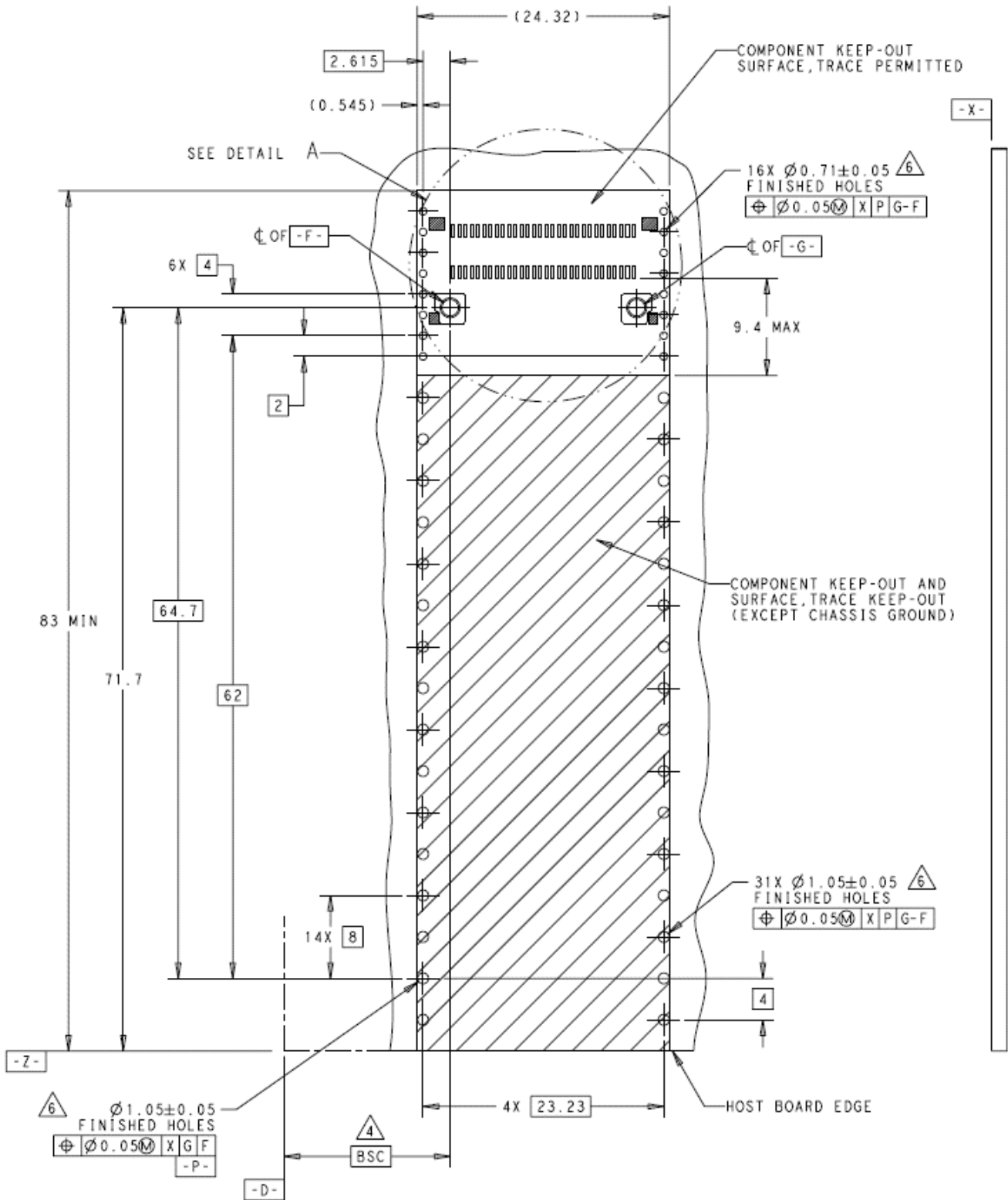

Figure 5

*Recommended PC Board Layout
(1x4 Cage Assembly Single Sided Configuration)*

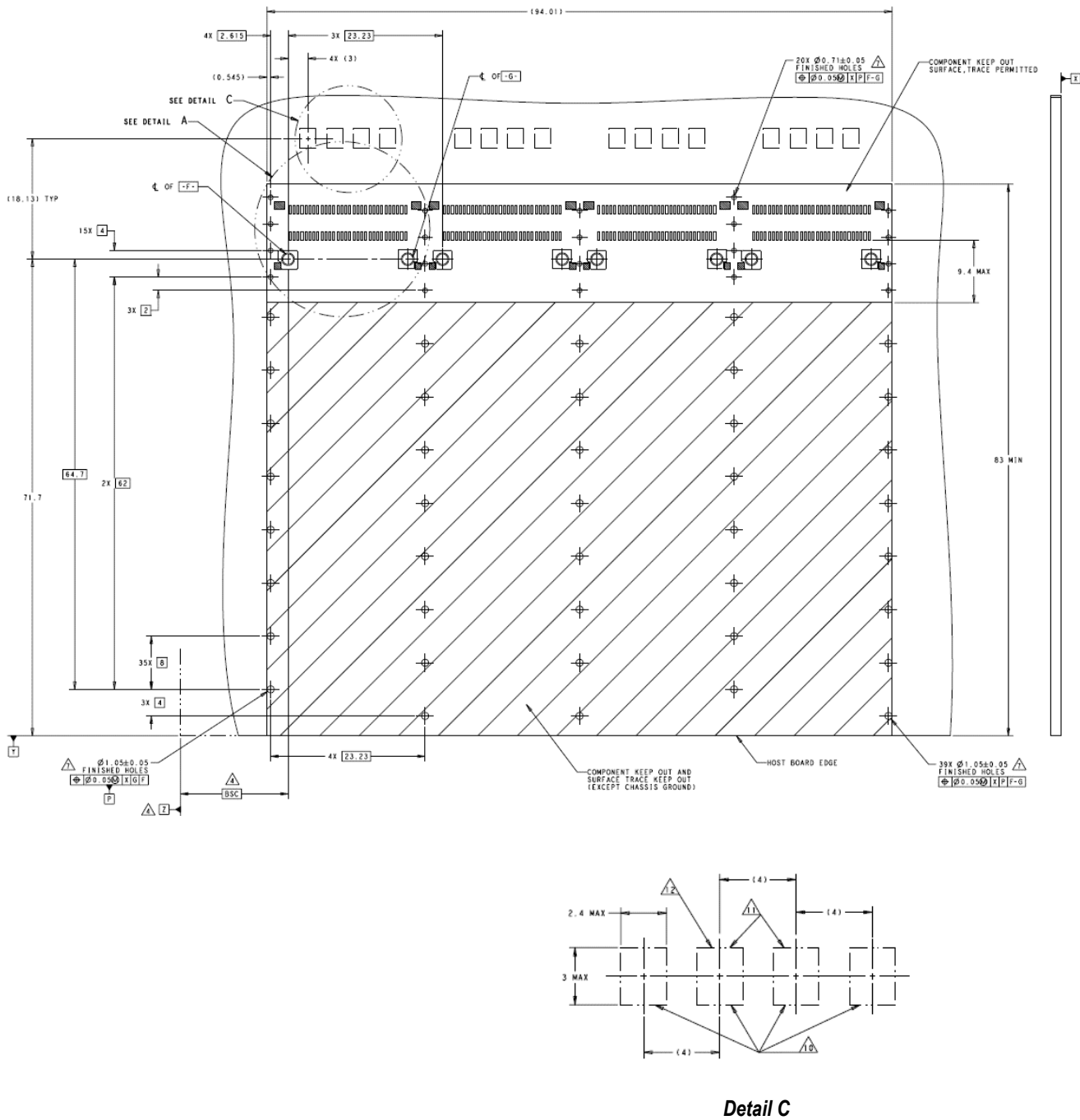

Figure 6

Recommended PC Board Layout
(1X4Cage Assembly Belly-to-Belly Configuration)

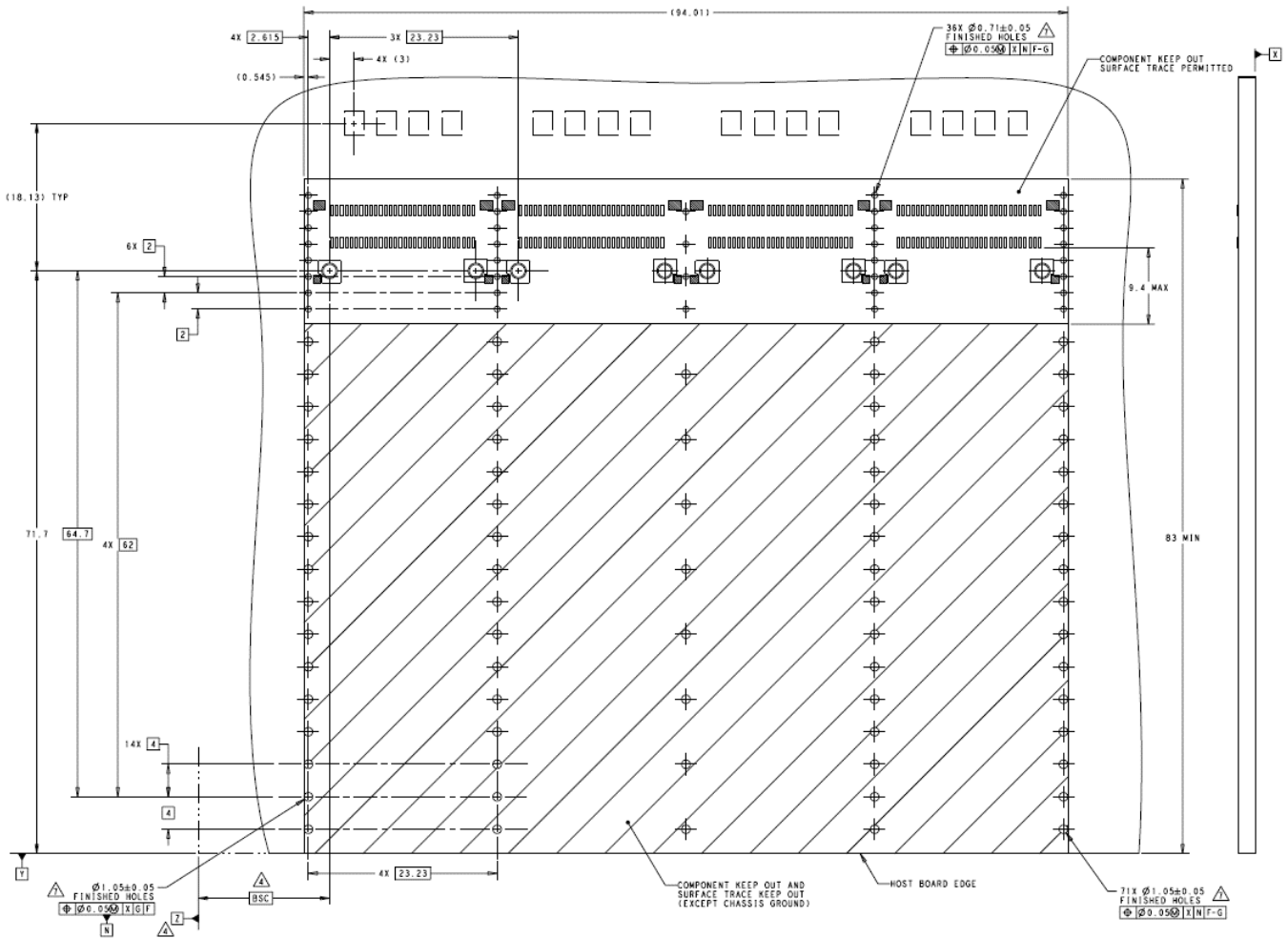

Figure 7

3.6. Transceiver Modules

The mating transceiver module dimensions must conform to the mechanical requirements specified in the OSFP MSA specification to insure there are no module interference issues when transceivers are installed in adjacent ports.

3.7. Bezel

A. Thickness

The bezel thickness range shall be 0.8 through 2.6 mm.

B. Cutout

The bezel must provide a cutout that allows proper mounting of the connector and cage assembly. The cage assembly panel ground springs must be compressed by the bezel in order to provide an electrical ground between the connector and cage assembly and bezel for EMI suppression. Care must be used to avoid interference between adjacent connector and cage assemblies and other components. The minimum allowable distance between connector and cage assemblies must be considered to ensure proper assembly. Dimensions for bezel cutout and minimum allowable distance between cutouts are shown in Figure 8.

Recommended Bezel Cutout and Minimum Pitch

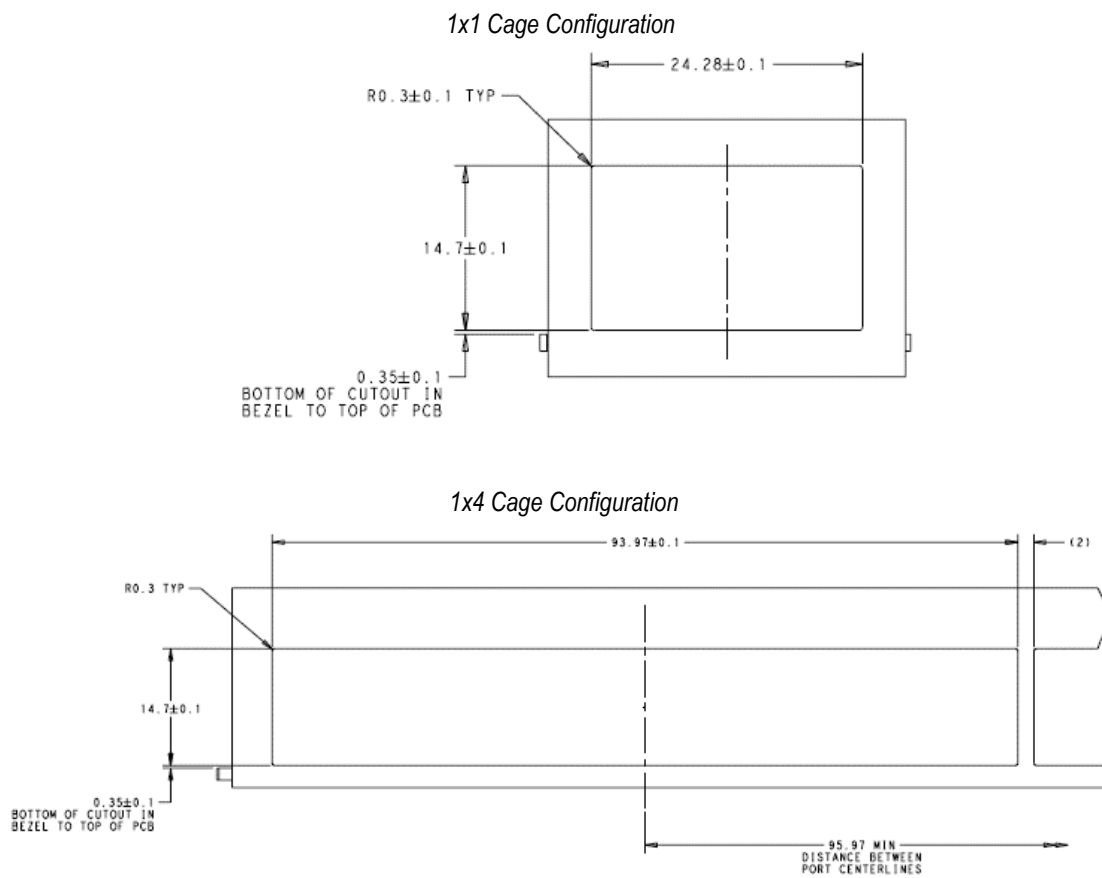
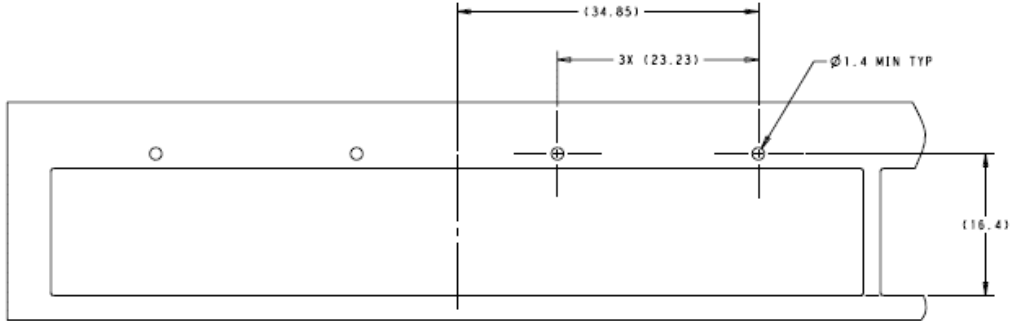

Figure 8 (Cont'd)

Recommended Bezel Cutout and Minimum Pitch

1x4 Cage with 1 Light Pipe per Port Configuration



1x4 Cage with 2 Light Pipe per Port Configuration

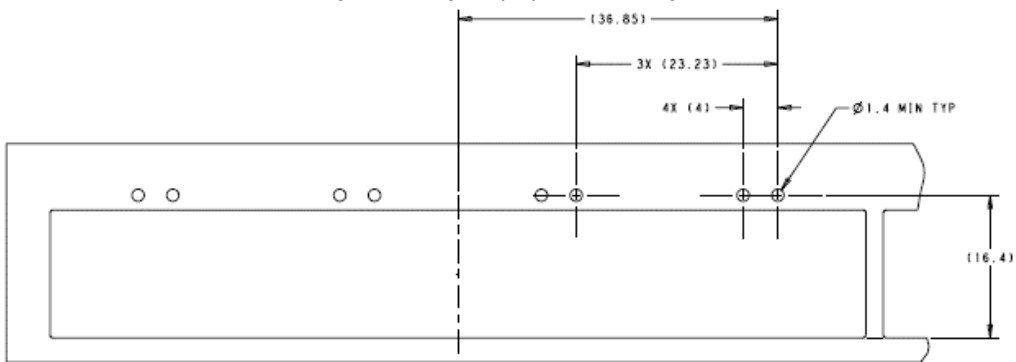

1x4 Cage with 4 Light Pipe per Port Configuration

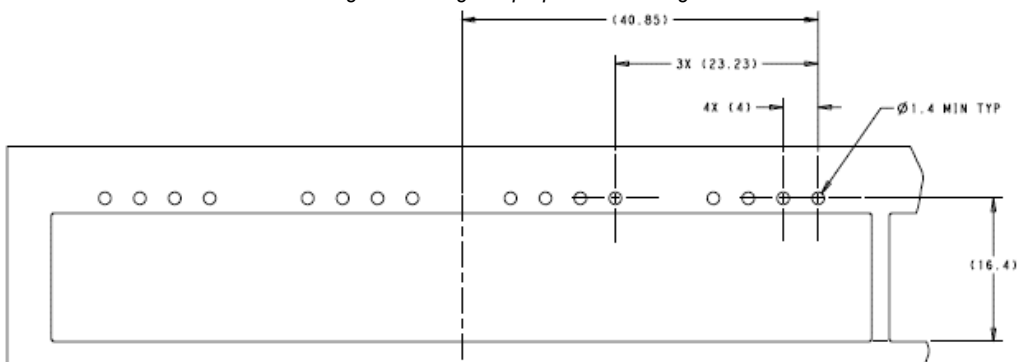

Figure 8 (End)

3.8. PC Board and Bezel Position

The bezel and pc board must be positioned in relation to each other to avoid interference with the insertion and extraction of the transceiver. The relationship must conform to the dimensions given in Figure 9.

*Recommended Bezel and PC Board Position
(EMI Spring Configuration)*

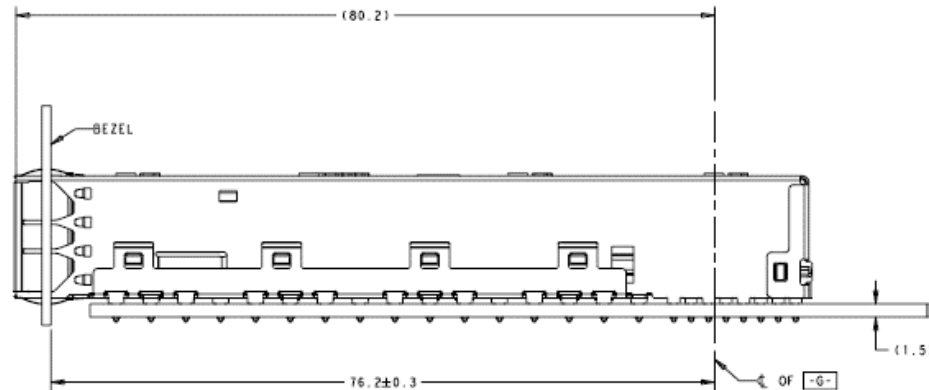

Figure 9

3.9. Placement

The following requirements also apply to cage assemblies used for rework purposes.

A. Registration

The compliant pin contacts and mounting posts must be aligned with the matching holes in the pc board, then inserted into the pc board simultaneously to prevent twisting or bending of the compliant pin contacts.

B. Seating

Using proper seating force and seating height is essential to interconnection performance. The force used to seat the cage assembly must be applied evenly to prevent deformation or other damage to the compliant pin contacts. The force required to seat the connector and cage assembly onto the pc board can be calculated by:

Amount of Compliant Pin Contacts X 44.5N (10 lbs) Force per Compliant Pin =

Over-driving the cage assembly will deform parts critical to the quality of the connection. Maximum force occurs prior to the connector and cage assembly bottoming on the pc board.

The shut height of the application tool must be specifically set for proper seating of the cage assembly. The shut height can be calculated by:

Seating Height (Cage Seated) + Height of Seating Tool + Combined Thickness of PC Board and PC Board Support Fixture = Shut Height (Ram Down)

The seating height, measured from the top of the cage assembly (not including the panel ground springs) to the top of the PC board is shown in Figure 10.

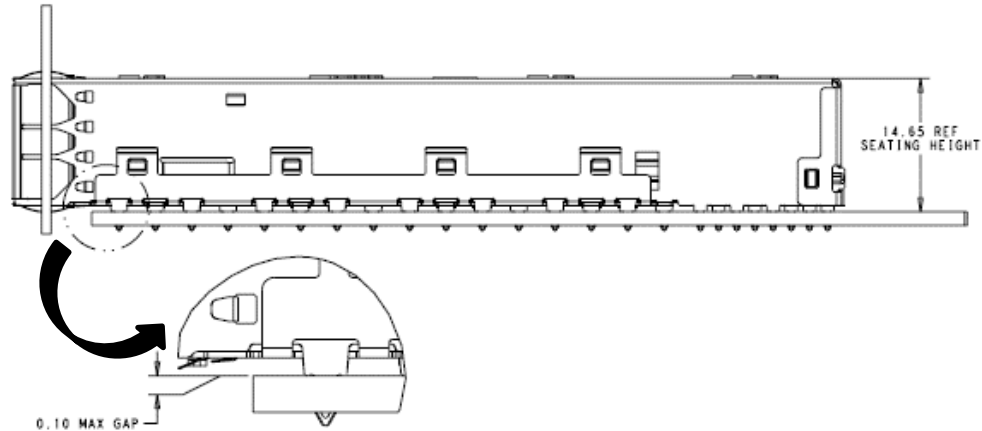

Figure 10

3.10. Checking the Assembly

After assembly, the cage assembly EMI springs must be compressed by the bezel. A slight bow in the cage assembly is permitted. The bezel and PC board must be positioned according to the dimensions shown in Figure 9.

3.11. EMI plug and Dust Cover

An EMI plug must be installed into the port when a transceiver module is not mated with the cage assembly to prevent EMI leakage. Alternatively, if EMI leakage is not a concern, a dust cover can be used to protect the connector.

3.12. Light Pipe Kits

A light pipe kit may be installed on the OSFP ganged Cage Assemblies. The Bezel must have additional cutouts as shown in Figure 8 for the light pipe kits. The number of bezel holes required is dependent on the number of light pipe openings desired. The appropriate location of the LED's on the host PC board is provided in Figure 6.

When a light pipe kit is installed, the rear organizer must be latched into the mounting tabs on the rear of the cage assembly. The light pipe bracket must also be latched onto the latch tabs on the main cage body. See Figure 11.

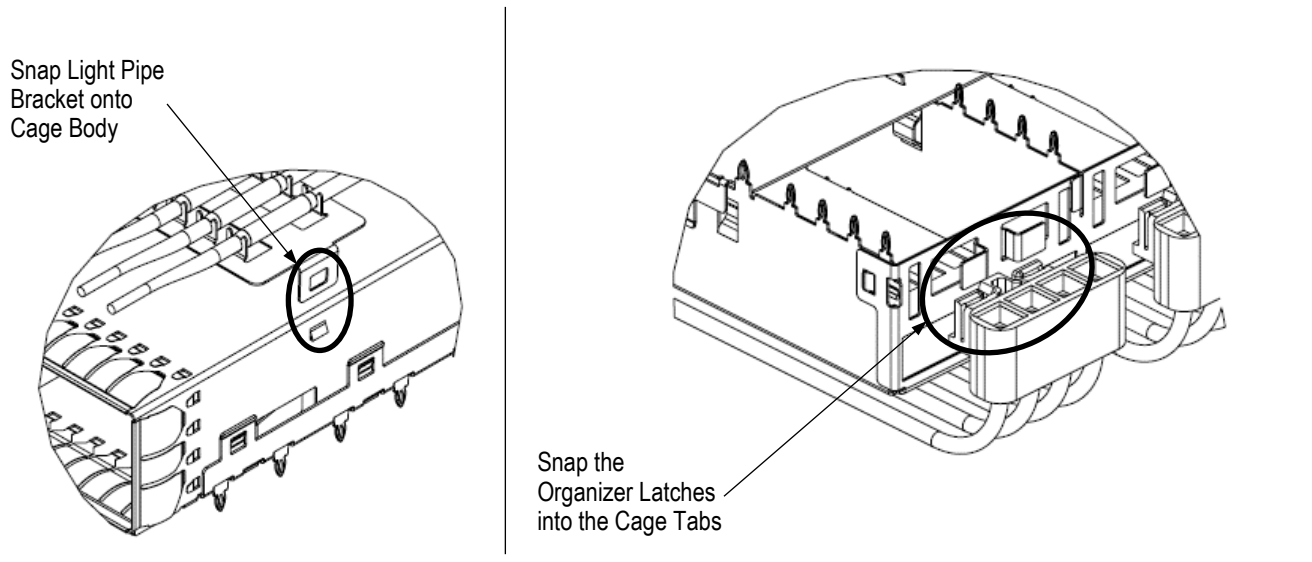

Figure 11

3.13. Repair and Rework

Damaged or defective connector and cage assemblies must be removed and replaced.

The cage assembly must be removed from the host pc board before removing the connector. Standard de—soldering methods must be used to remove the connector from the host pc board. The connector **MUST NOT** be re--used after removal. The connector and cage assembly are not repairable. Any defective or damaged products **MUST NOT** be re--used.

4. QUALIFICATION

The OSFP Cage qualification testing was not complete at the time of publication of this document.

5. TOOLING

Tooling Part Numbers and instructional material packaged with the tooling are given in Figure 12.

5.1. Seating Tool Kits

Although a simple flat rock process may be used to seat the cage assembly, TE designed seating tool kits (each consisting of a seating tool and wall support) that may be used to accurately insert the connector and cage assembly onto the PC board. The seating tool and wall support are also available separately.

5.2. Extraction Tool

The extraction tool is used to remove the connector and cage assembly from the pc board. The connector and cage assembly cannot be reused.

5.3. Application Tool

Power for the seating tools and extraction tools must be provided by an application tool (with a ram) capable of supplying a downward force of 44.5N (10 lbs) per compliant pin. For available application tools, call Product Information at the number on the bottom of page 1.

5.4. PC Board Support Fixture

A PC board support kits must be used with the seating tool and extraction tool. The support fixture provides proper support for the PC board and protects the board and the connector and cage assembly from damage. The support fixture must be customer designed. It is recommended that the support fixture be at least 25.4 mm

longer and wider than the PC board. And have flat surfaces with holes or a channel large enough and deep enough to receive any protruding components of the connector and cage assembly.

CAGE CONFIGURATION (Cage Part Number)	SEATING TOOL KIT	CAGE EXTRACTION TOOL
1X1 (2317416-1 and -2)	TBD	2185245-1
1X4 (2315853-1 and -3)	2185244-1	2185245-4
1X4 (2315853-5)	2185244-2	2185245-4

Typical Seating Tool Kit
(Refer to Table)

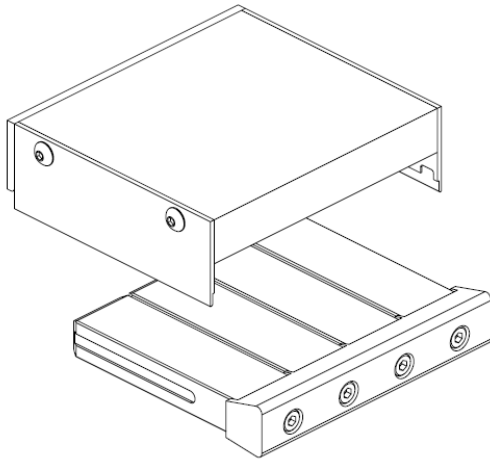

Typical Extraction Tool Kit
(Refer to Table)

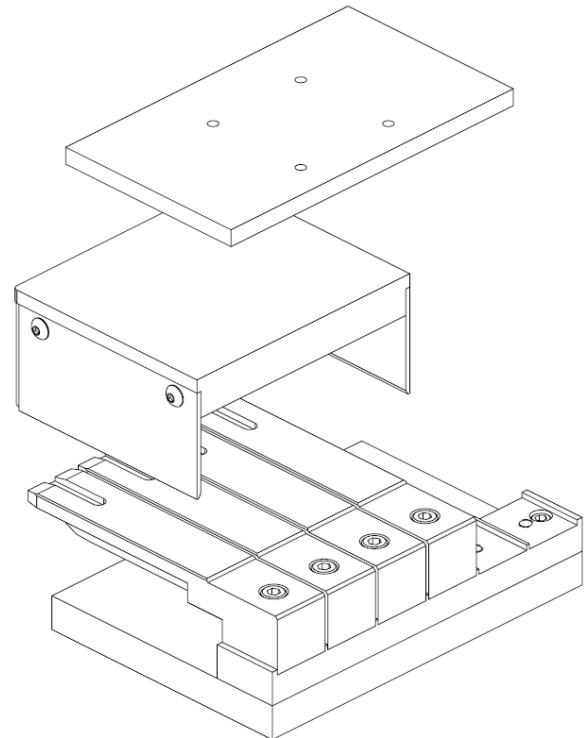

Figure 12

6. VISUAL AID

The illustration below shows a typical application of this product. This illustration should be used by production personnel to ensure a correctly applied product. Applications which do not appear correct should be inspected using the information in the preceding pages of this specification and in the instructional material shipped with the product or tooling.

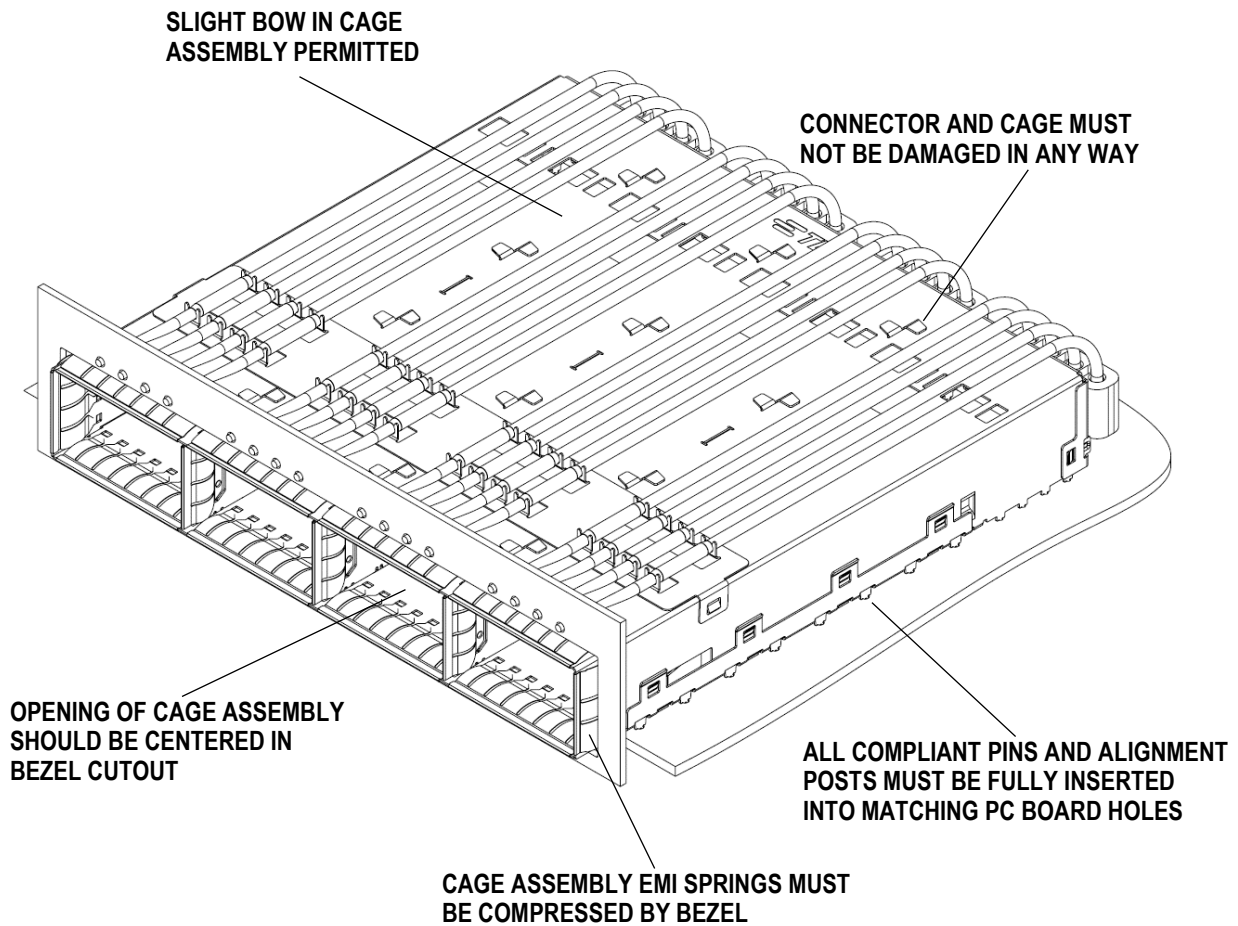

FIGURE 13. VISUAL AID