

DEBUR AND BREAK SHARP EDGES

DO NOT SCALE DRAWING

REVISION

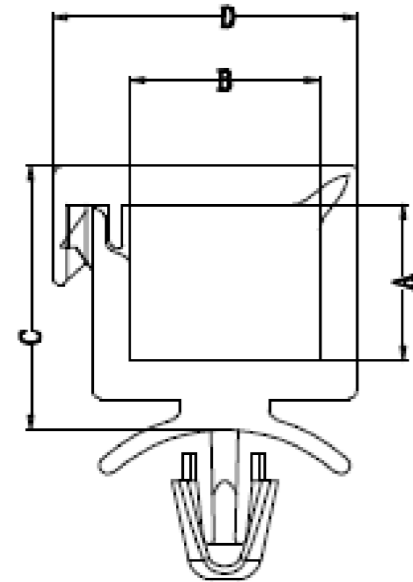
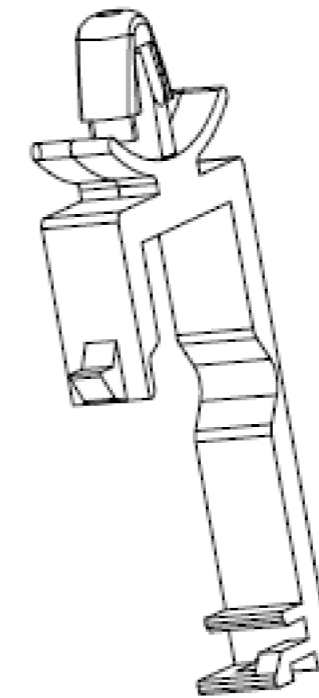
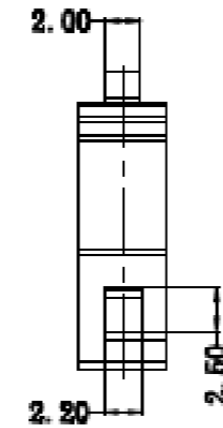
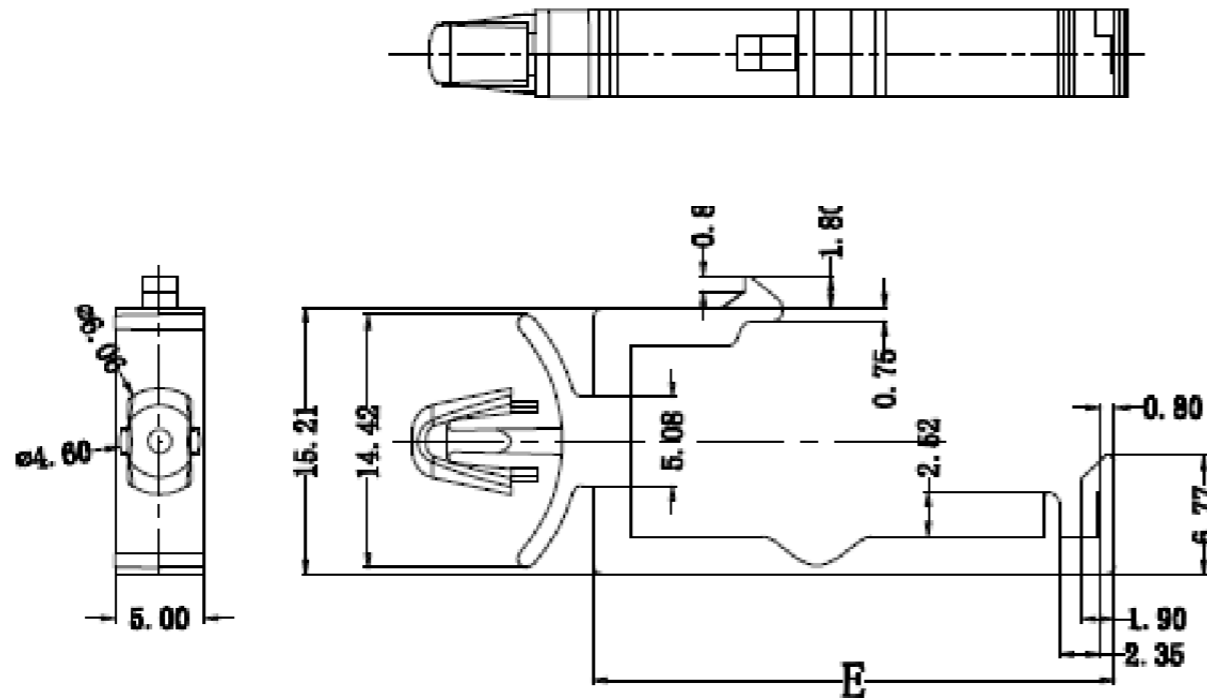

PART No.	HOLE DIA.	"A"	"B"	"C"	"D"	"E"
TRWSLT-01-2-01	4.8	8.8	10.7	14.6	16.8	14.3
TRWSLT-01A-01	4.8	4.8	10.7	10.6	16.8	14.3
TRWSLT-02-1-01	4.8	3.4	13.5	9.4	19.6	14.3
TRWSLT-02A-01	4.8	10.0	16.3	15.8	22.4	14.3
TRWSLT-03-2-1	4.8	14.1	16.3	19.6	22.4	14.3
TRWSLT-03-3-01	4.8	21.7	18.0	27.3	24.1	14.3
TRWSLT-3.5-2-1-01	3.5	3.4	13.5	8.9	19.6	9.5

C Pt No.TABLE ADDED
M.E. 27/07/14
B DRG NO CHANGED
M.E. 19/06/14
A DRAWN 04/11/13

NOTES

1. MATERIAL: PA66 UL94 V2;
2. COLOR: NATURAL;
3. ROHS Compliant;
4. Hole: $\text{C}4.75 \pm 0.08\text{mm}$,
Panel Thickness: 1.57mm;



DESIGN RIGHT. TR FASTENINGS LTD, 2003
UNDER NO CIRCUMSTANCES MUST THIS
DRAWING BE COPIED OR DISCLOSED,
WITHOUT FIRST OBTAINING WRITTEN
AUTHORITY.

UNLESS OTHERWISE SPECIFIED:
DIMENSIONS ARE IN MILLIMETERS
SURFACE FINISH:
TOLERANCES:

ISO 2768 m	NAME	DATE
	DRAWN MARTIN ELLIOTT	04/11/13
	CHK'D	
	APPV'D	

CUSTOMER PART No

MATERIAL:

SEE NOTES

HEAT TREATMENT

N/A

FINISH:

N/A

TITLE:

WIRE SADDLE LOCKING TOP

DWG NO.

TRWSLT-XX-01

A3

PROJECTION

