

DEBUR AND BREAK SHARP EDGES

DO NOT SCALE DRAWING

REVISION

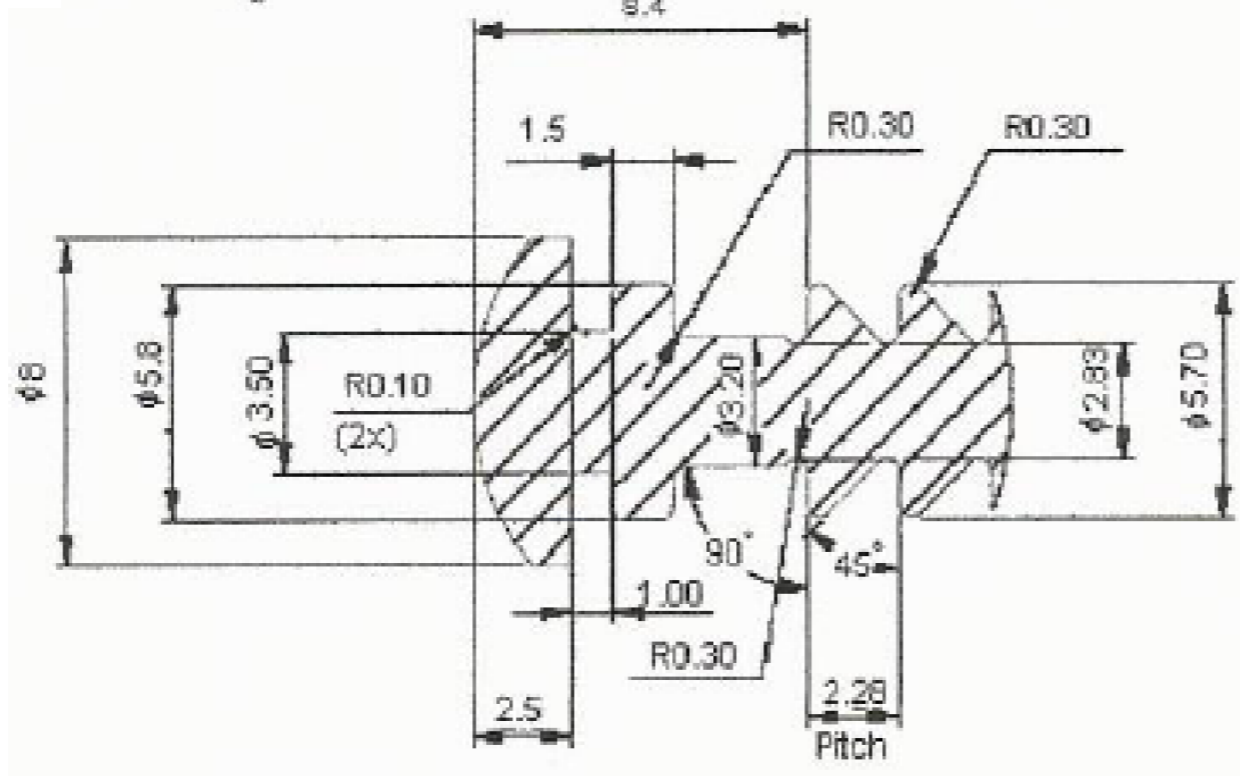
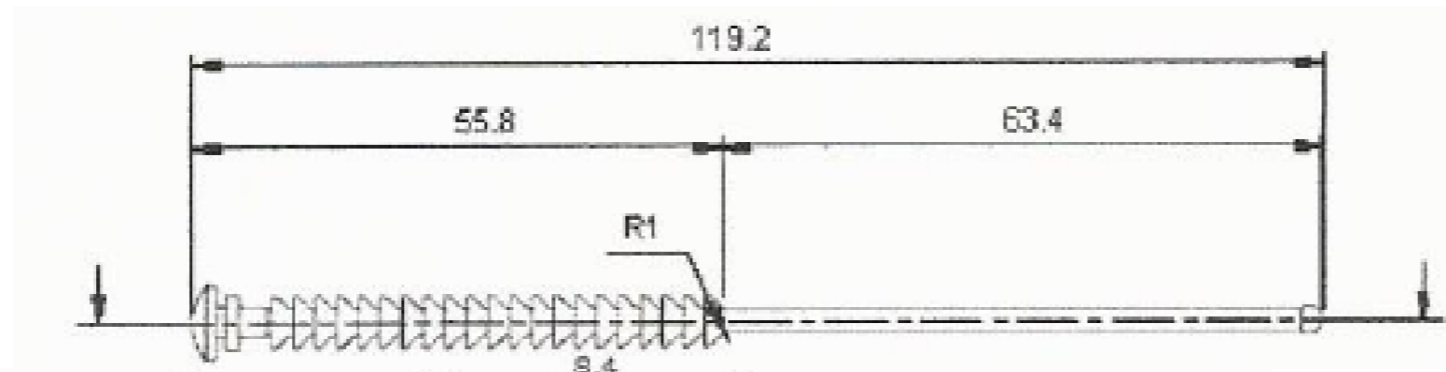
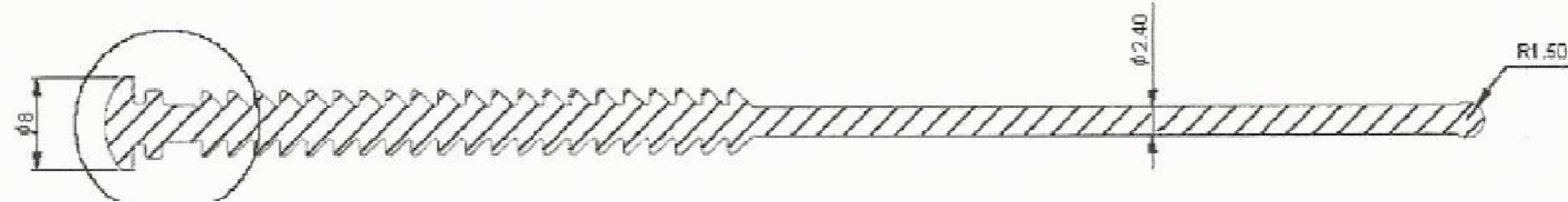

NOTES

- 1) MATERIAL - SILICONE RUBBER, 35 SHORE A - BLACK
- 2) FITS INDUSTRY STD DC FAN RANGES:- 10mm TO 51mm THICK
- 3) FIXING HOLE:- $\phi 3.2\text{mm}$ TO $\phi 4.5\text{mm}$
- 4) CHASSIS MOUNTING HOLE RANGE:- $\phi 4.5\text{mm}$ TO $\phi 4.8\text{mm}$, THICKNESS 1.0mm TO 1.5mm



DESIGN RIGHT. TR FASTENINGS LTD, 2003
UNDER NO CIRCUMSTANCES MUST THIS
DRAWING BE COPIED OR DISCLOSED,
WITHOUT FIRST OBTAINING WRITTEN
AUTHORITY.

UNLESS OTHERWISE SPECIFIED:
DIMENSIONS ARE IN MILLIMETERS
SURFACE FINISH:
TOLERANCES:

ISO 2768 m

NAME	DATE
DRAWN MARTIN ELLIOTT	16/07/14
CHK'D	
APP'VD	

CUSTOMER PART No

MATERIAL:

SEE NOTES

HEAT TREATMENT

N/A

FINISH:

N/A

TITLE:

MULTI FAN MOUNT

DWG NO.

TRFMM-1

A3

PROJECTION

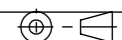

SHEET 1 OF 1

A

DRAWN 16/07/14