

DEBUR AND BREAK SHARP EDGES

DO NOT SCALE DRAWING

REVISION

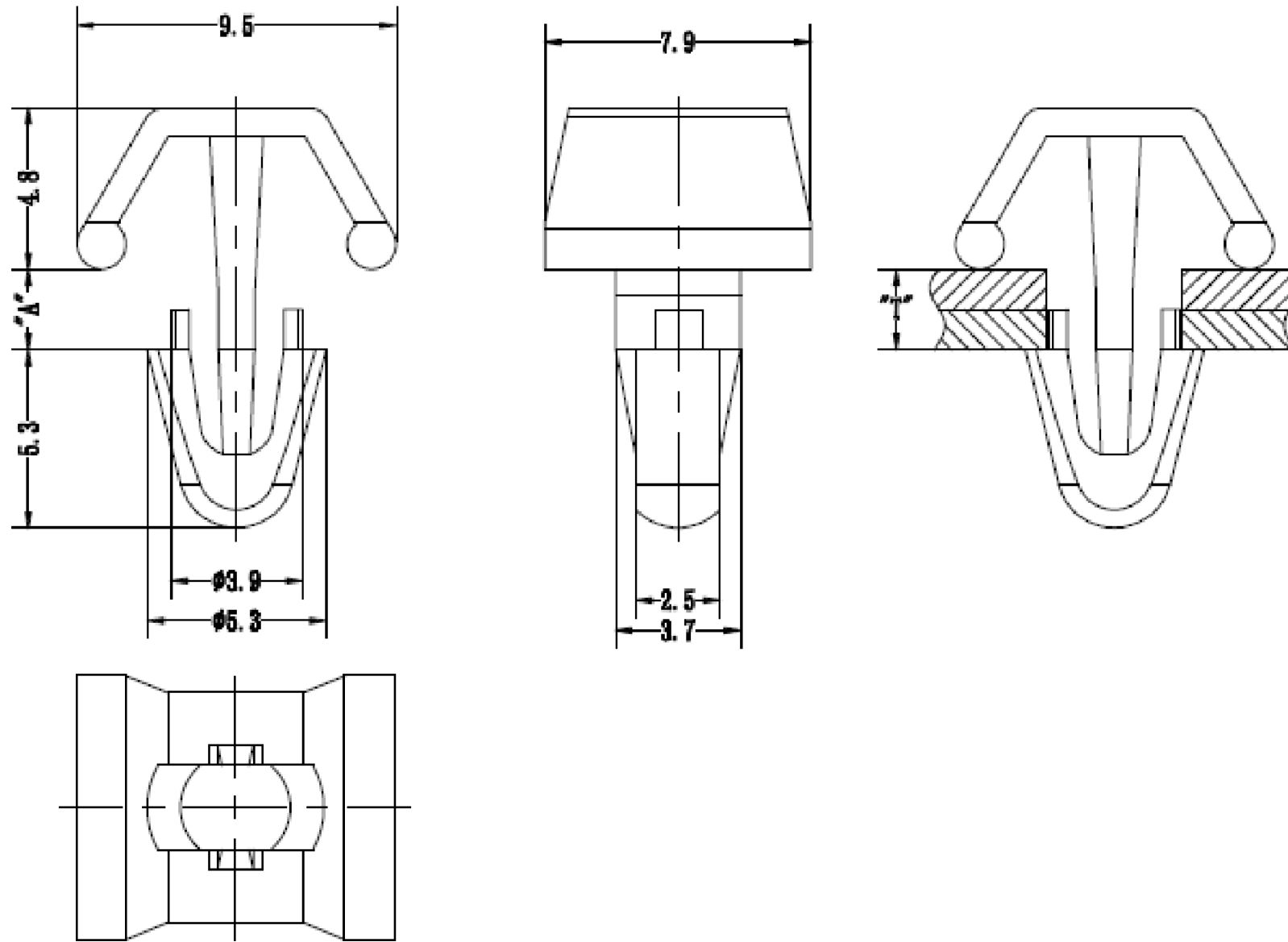

C	DRG No WAS TRMB-X-66 M.E. 26/06/14
B	DRG No CHANGED M.E. 18/06/14
A	DRAWN 01/11/13

NOTES

1. MATERIAL: NYLON 66 UL-94V2;
2. COLOR: NATURAL;
3. ROHS Compliant;
4. Hole: $\varnothing 4.0 \pm 0.08\text{mm}$



DESIGN RIGHT. TR FASTENINGS LTD, 2003
UNDER NO CIRCUMSTANCES MUST THIS
DRAWING BE COPIED OR DISCLOSED,
WITHOUT FIRST OBTAINING WRITTEN
AUTHORITY.

UNLESS OTHERWISE SPECIFIED:
DIMENSIONS ARE IN MILLIMETERS
SURFACE FINISH:
TOLERANCES:

ISO 2768 m	
NAME	DATE
DRAWN MARTIN ELLIOTT	01/11/13
CHK'D	
APPV'D	

CUSTOMER PART No

MATERIAL:
SEE NOTES

HEAT TREATMENT
N/A

FINISH:
N/A

TITLE:
MOUNTING BUTTON

DWG NO.
TRMB-1-156

A3