

DEBUR AND BREAK SHARP EDGES

DO NOT SCALE DRAWING

REVISION

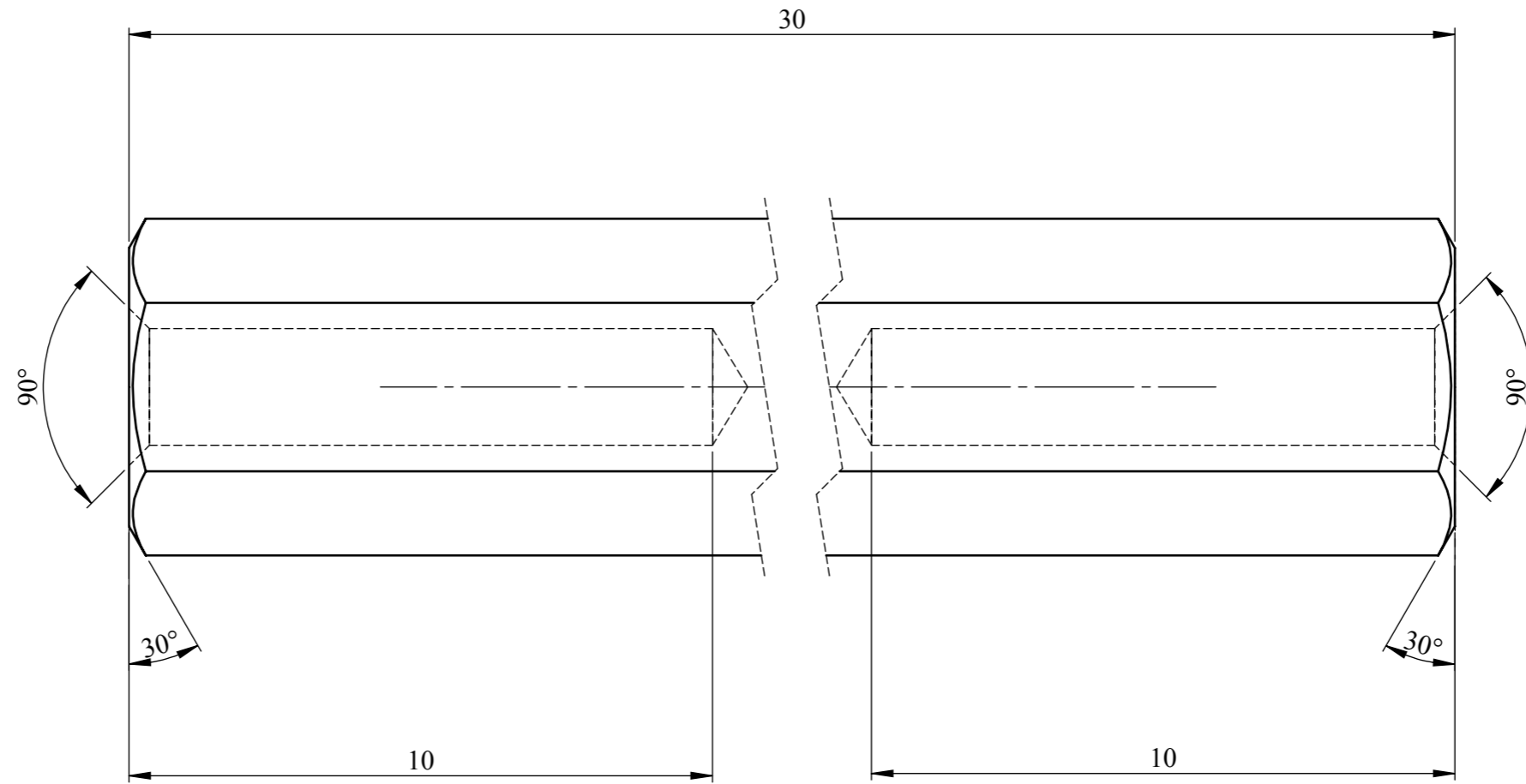
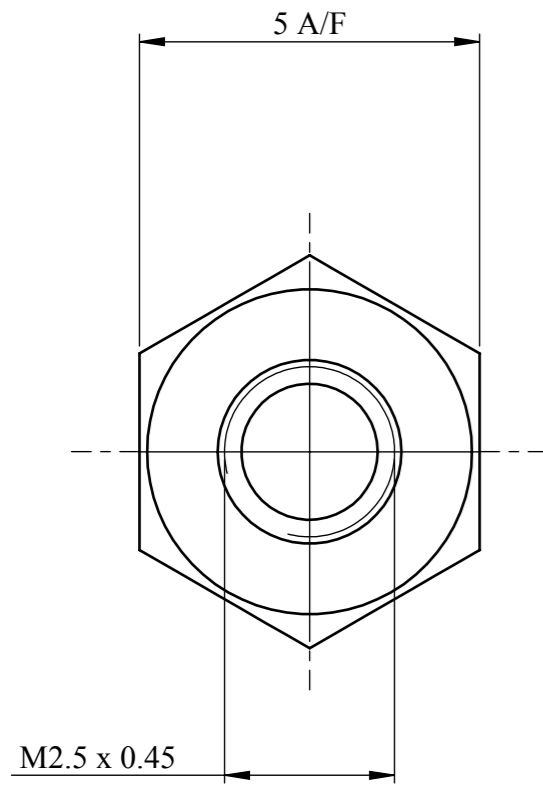

NOTES



DESIGN RIGHT. TR FASTENINGS LTD, 2003  
 UNDER NO CIRCUMSTANCES MUST THIS  
 DRAWING BE COPIED OR DISCLOSED,  
 WITHOUT FIRST OBTAINING WRITTEN  
 AUTHORITY.

UNLESS OTHERWISE SPECIFIED:  
 DIMENSIONS ARE IN MILLIMETERS  
 SURFACE FINISH:  
 TOLERANCES:

ISO 2768 m	
NAME	DATE
DRAWN MARTIN ELLIOTT	07/12/15
CHK'D	
APPV'D	

CUSTOMER PART No

MATERIAL:

STEEL - 11SMnPb30

HEAT TREATMENT

N/A

FINISH:

ZINC PLATE A2F

TITLE:

M2.5 x 30 F/F HEXAGON SPACER

DWG NO.

FAHSSFFM2.5-30-5

A3

A

DRAWN - 07/12/15

PROJECTION

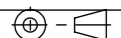

SHEET 1 OF 1