

# NCV7450

## CAN + LDO + HS Driver System Basis Chip

The system basis chip (SBC) NCV7450 integrates +5 V / 250 mA LDO with a high-speed CAN transceiver and one high-side driver with diagnostics, directly controlled by dedicated pins.

### Features

- 5 V  $\pm$ 2% / 250 mA LDO
  - ◆ Current Limitation
  - ◆ Output Voltage Monitoring
- One High-Speed CAN Transceiver
  - ◆ Current Limitation, Reverse Current Protected
  - ◆ Compliant to ISO11898-2:2016
  - ◆ TxDC Time-out
- One High-Side Driver
  - ◆  $R_{dson} = 300 \text{ m}\Omega @ 25^\circ\text{C}$
  - ◆ Current Limitation
  - ◆ Diagnostic Output
  - ◆ Over-Current Protection
  - ◆ Under-Load Detection
- Direct Control
- Window Watchdog
- Two-level Thermal Shutdown Protection
- AEC-Q100 Qualified and PPAP Capable
- These Devices are Pb-Free, Halogen Free/BFR Free and are RoHS Compliant

### Typical Applications

- Automotive
- Industrial Networks



ON Semiconductor®

[www.onsemi.com](http://www.onsemi.com)



16

1

TSSOP16-EP  
CASE 948BV

### MARKING DIAGRAM

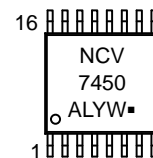

NCV7450 = Specific Device Code  
A = Assembly Location  
L = Wafer Lot  
Y = Year  
W = Work Week  
▪ = Pb-Free Package

### ORDERING INFORMATION

Device	Package	Shipping†
NCV7450DB0R2G	TSSOP16-EP (Pb-Free)	4000 / Tape & Reel

†For information on tape and reel specifications, including part orientation and tape sizes, please refer to our Tape and Reel Packaging Specifications Brochure, BRD8011/D.

# NCV7450

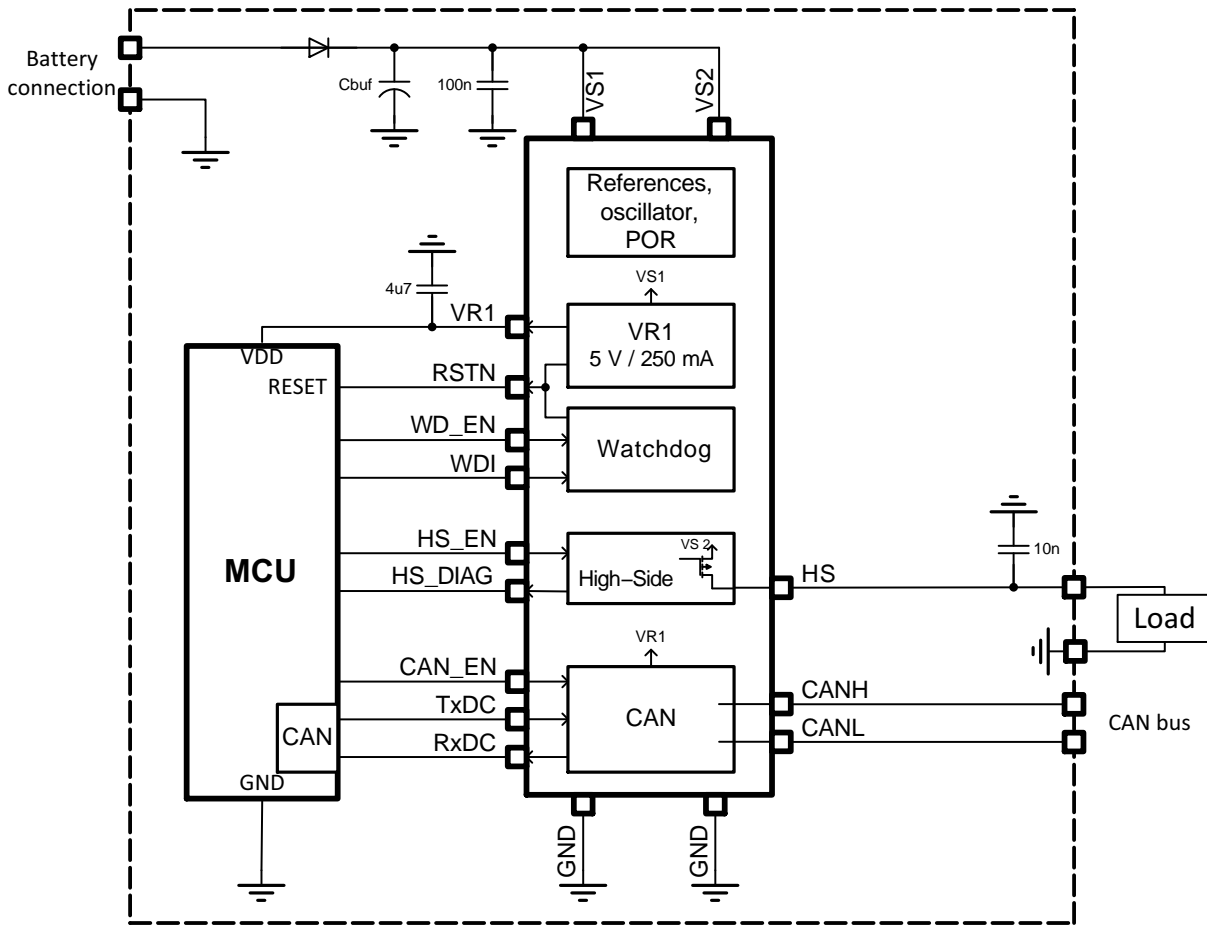

**Figure 1. Simplified Application Diagram**

**Table 1. PIN DESCRIPTION**

Pin No.	Pin Name	Pin Type (LV = Low Voltage; HV = High Voltage)	Description
1	VR1	LV supply output	Output of the 5 V / 250 mA low-drop regulator
2	WD_EN	LV digital input; internal pull-up current	Watchdog disable input
3	RSTN	LV digital output; open drain; internal pull-up	Reset signal to the MCU
4	TxDC	LV digital input; internal pull-up	CAN transmitter data input
5	HS_DIAG	LV digital output; push-pull	HS driver diagnostic output (active Low)
6	RxDC	LV digital output; push-pull	CAN receiver data output
7	WDI	LV digital input; internal pull-down	Watchdog trigger input
8	HS_EN	LV digital input; internal pull-down	HS driver enable input
9	CAN_EN	LV digital input; internal pull-down	CAN transceiver enable input
10	GND	Ground connection	Ground supply (all GND pins have to be connected externally)
11	CANH	CAN bus interface	CANH line of the CAN bus
12	CANL	CAN bus interface	CANL line of the CAN bus
13	GND	Ground connection	Ground supply (all GND pins have to be connected externally)
14	HS	HV output; high-side	High-side driver output
15	VS2	HV supply input	Main supply input (HS Driver), keep floating if HS driver not used
16	VS1	HV supply input	Main supply input (VR1, logic)
	EP	Exposed pad	Substrate (has to be connected to all GND pins externally)

# NCV7450

**Table 2. MAXIMUM RATINGS**

Symbol	Rating	Min	Max	Unit	
Vmax_VS1	DC Power Supply Voltage (Note 1)	-0.3	40	V	
Vmax_VS2	DC Power Supply Voltage (Note 1)	-0.3	40	V	
Vmax_HS	DC High-side driver Voltage	-0.3	VS2+0.3	V	
Vmax_digIO	DC voltage on digital pins (CAN_EN, WD_EN, WDI, RSTN, RxDC, TxDC, HS_EN, HS_DIAG)	-0.3	VR1+0.3	V	
Vmax_CAN	DC voltage on pin CANH and CANL	-40	40	V	
Vmax_diff	Differential DC voltage between any two pins (incl. CANH and CANL)	-40	40	V	
Vmax_VR1	LDO Supply pin output voltage	-0.3	6 or VS1+0.3 (whichever is lower)	V	
Tj	Junction Temperature Range	-40	150	°C	
Tstg	Storage Temperature Range	-55	150	°C	
V_ESDHBM	ESD Capability, Human Body Model (Note 2)	All pins	-4	+4	kV
V_ESDHBM	ESD Capability, Human Body Model (Note 2)	Pins VS1/2, CANH, CANL, HS	-5	+5	kV
V_ESDMM	ESD Capability, Machine Model (Note 2)		-250	+250	V
V_ESDCDM	ESD Capability, Charged Device Model (Note 2)		-750	+750	V
V_ESDIEC	System ESD Capability (Note 2), pins VS, CANH, CANL, HS		-6	+6	kV
V_SCHAF	Voltage transients per ISO7637 – 3, Class D, pins VS, CANH and CANL	Test pulse 1	-100		V
		Test pulse 2a		+75	V
		Test pulse 3a	-150		V
		Test pulse 3b		+100	V
MSL	Moisture Sensitivity Level		2	-	

Stresses exceeding those listed in the Maximum Ratings table may damage the device. If any of these limits are exceeded, device functionality should not be assumed, damage may occur and reliability may be affected.

1. Refer to ELECTRICAL CHARACTERISTICS, RECOMMENDED OPERATING RANGES and/or APPLICATION INFORMATION for Safe Operating parameters.
2. This device series incorporates ESD protection and is tested by the following methods:  
 Device ESD Human Body Model tested per AEC-Q100-002 (EIA/JESD22-A114)  
 Device ESD Machine Model tested per AEC-Q100-003 (EIA/JESD22-A115)  
 Device ESD Charged Device Model tested per AEC-Q100-011 (EIA/JESD22-C101)  
 System ESD Human Body Mode tested per IEC61000-4-2 (150 pF, 330 Ω)  
 Latchup Current Maximum Rating: ≤ 150 mA per JEDEC standard: JESD78.
3. For information, please refer to our Soldering and Mounting Techniques Reference Manual, SOLDERRM/D.

**Table 3. THERMAL CHARACTERISTICS**

Symbol	Rating	Value	Unit
R <sub>θJA</sub> R <sub>ψJA</sub>	Thermal Characteristics, Thermal Resistance, Junction-to-Air (Note 4) Thermal Resistance, Junction-to-Air (Note 5)	54 81	°C/W
R <sub>θJC</sub>	Thermal Characteristics, Thermal Resistance, Junction-to-Case	10.5	°C/W

4. Value based on test board according to JESD51-3 standard, signal layer with 10% trace coverage.
5. Value based on test board according to JESD51-7 standard, signal layers with 20% trace coverage, inner planes with 90% coverage.

# NCV7450

**Table 4. RECOMMENDED OPERATING RANGES**

Symbol	Rating	Min	Max	Unit
VS1	Functional supply voltage	5	28	V
	Supply voltage for valid parameter specification	6	18	V
VS2	Functional supply voltage	4.3	24	V
	Supply voltage for valid parameter specification	6	18	V
VR1	VR1 LDO output voltage	4.9	5.1	V
VdigIO	Digital inputs/outputs voltage	0	VR1	V
HS	High side driver voltage	0	VS2	V
CANH, CANL	CAN bus pins voltage	0	VR1	V
T <sub>J</sub>	Junction Temperature	-40	150	°C
T <sub>A</sub>	Ambient Temperature	-40	125	°C

Functional operation above the stresses listed in the Recommended Operating Ranges is not implied. Extended exposure to stresses beyond the Recommended Operating Ranges limits may affect device reliability.

**Table 5. ELECTRICAL CHARACTERISTICS** (6 V ≤ Vs1 = Vs2 ≤ 18 V; -40°C ≤ Tj ≤ 150°C; unless otherwise specified.)

Symbol	Parameter	Conditions	Min	Typ	Max	Unit
<b>VS1, VS2 Supply</b>						
VS_PORH	VS1 POR threshold	VS1 rising	3.4		4.1	V
VS_PORL	VS1 POR threshold	VS1 falling	2		3.5	V
Is1_off	VS1 consumption, low-power	VS1 = VS2 = 14 V, VR1 on (not loaded), HS load to GND, CAN bus recessive, CAN_EN = Low, HS_EN = Low, WD_EN = Low, Tj ≤ 85°C		25		μA
Is2_off	VS2 consumption, low-power	VS1 = VS2 = 14 V, HS load to GND, HS_EN = Low, Tj ≤ 85°C		4		μA
Is_act	VS1+VS2 consumption, active	VS1 = VS2 = 14 V, VR1 on (loaded by 100 mA, not included in Is_act), HS floating, CAN bus recessive, CAN_EN = High, HS_EN = High, WD_EN = High, TxDC = High		10	20	mA
VS2_OV	VS2 over-voltage	HS_EN = High	28			V
VS2_OV_hyst	VS2 over-voltage hysteresis	HS_EN = High		1		V
Tfilt_VS2_OV	VS2 over-voltage filter time	VS2 rising	60		105	μs

**VR1 Voltage Regulator**

V_VR1	Regulator output voltage	0 mA ≤ I(VR1) ≤ 250 mA, 6 V ≤ VS1 ≤ 28 V	4.9	5	5.1	V
Iout_VR1	Regulator output current	Maximum VR1 load current			250	mA
Ilim_VR1	Regulator current limitation	Maximum VR1 overload current, VR1 > RES_VR1	400		1000	mA
Ishort_VR1	Regulator short current	Maximum VR1 short current, VR1 < RES_VR1	133	$\frac{1}{3} \cdot Ilim\_VR1$	333	mA
Vdrop_VR1	Dropout Voltage	I(VR1) = 100 mA, VS1 = 5 V ·Tj ≤ 150°C ·Tj ≤ 40°C (Note 6) ·Tj = -40°C		0.2	0.4	V
		I(VR1) = 100 mA, VS1 = 4.5 V			0.5	
		I(VR1) = 50 mA, VS1 = 4.5 V			0.4	
Loadreg_VR1	Load Regulation	1 mA ≤ I(VR1) ≤ 100 mA	-50		50	mV
Linereg_VR1	Line Regulation	I(VR1) ≤ 100 mA	-30		30	mV
Cload_VR1	VR1 load capacity	ESR < 200 mΩ, ceramic capacitor recommended	1	4.7		μF

# NCV7450

**Table 5. ELECTRICAL CHARACTERISTICS** ( $6\text{ V} \leq V_{s1} = V_{s2} \leq 18\text{ V}$ ;  $-40^{\circ}\text{C} \leq T_j \leq 150^{\circ}\text{C}$ ; unless otherwise specified.)

Symbol	Parameter	Conditions	Min	Typ	Max	Unit
<b>VR1 Voltage Regulator</b>						
RES_VR1	VR1 Reset threshold	VR1 voltage decreasing	4.3	4.5	4.7	V
RES_hyst_VR1	VR1 Reset threshold hysteresis		0.05	0.1	0.2	V
Tfilt_RES_VR1	VR1 undervoltage filter time			15		$\mu\text{s}$
Toff_VR1	VR1 off time after TSD			1		s
Is_add_VR1	VS consumption adder of VR1	(Note 6)		0.02· I(VR1)		A

## HS Driver

Ron_HS	On-resistance	$T_j = 25^{\circ}\text{C}$ (Note 6)		0.3		$\Omega$
		$T_j = 125^{\circ}\text{C}$ (Note 6)			0.6	
		$T_j = 125^{\circ}\text{C}$ , $V_{s2} = 4.3\text{ V}$ (Note 6)			0.8	
		$T_j = 150^{\circ}\text{C}$			0.7	
Ilim_HS	Current Limitation		-3.7	-3	-2.5	A
Ioc_HS	Overcurrent threshold		-3.7	-2.7	-1.7	A
Iuld_HS	Underload detection threshold		-40		-6	mA
Ileak_HS	Output leakage current	HS off ; $V(\text{HS}) = 0\text{ V}$ $T_j = 25^{\circ}\text{C}$ (Note 6) $T_j = 150^{\circ}\text{C}$	-1 -5			$\mu\text{A}$
td_on_HS	Output delay time	HS_EN = Low → High; $V(\text{HS}) = 0.1 \cdot V_{s2}$ ·HS_EN was Low for more than 30 ms ·HS_EN was Low for less than 20 ms		140 40		$\mu\text{s}$
td_off_HS	Output delay time	HS_EN = High → Low; $V(\text{HS}) = 0.9 \cdot V_{s2}$		40		$\mu\text{s}$
td_oc_HS	Over-current detection filter time				65	$\mu\text{s}$
tdb_uld_HS	Underload detection blanking delay	Timer started after driver activation and $V(\text{HS}) = V_{s2} - 2\text{ V}$			130	$\mu\text{s}$
td_uld_HS	Underload detection filter time	HS Driver active, tdb_uld_HS elapsed			70	$\mu\text{s}$
dVout_HS	Slew rate	HS load = $16\ \Omega$ to GND		0.2		$\text{V}/\mu\text{s}$
Is_add_HS	HS consumption from VS2	HS_EN = High; HS pin floating	2	4.4	8	mA

## Watchdog Timing (see Figure 2)

Twd_acc	Watchdog timing accuracy		-15		+15	%
T_wd_TO	Timeout watchdog period	After WD_EN low → high transition or RSTN pulse		65		ms
T_wd_CW	Window watchdog closed window			6		ms
T_wd_OW	Window watchdog open window			100		ms
T_RSTN	Reset pulse length after VR1 undervoltage or watchdog failure			8		ms
T_WDI	Minimum WDI pulse width accepted as a watchdog service		6			$\mu\text{s}$

## Digital Outputs, RxDC, HS\_DIAG

IoutL_pinx	Low-level output driving current	pinx is logical Low, forced $V(\text{pinx}) = 0.4\text{ V}$	1	6	12	mA
IoutH_pinx	High-level output driving current	pinx is logical High, forced $V(\text{pinx}) = V_{R1} - 0.4\text{ V}$	-8	-3	-1	mA

## Digital Output RSTN

IoutL_RSTN	Low-level output driving current	RSTN is active (logical Low), forced $V(\text{RSTN}) = 0.4\text{ V}$	2	5	12	mA
------------	----------------------------------	--	---	---	----	----

**Table 5. ELECTRICAL CHARACTERISTICS** (6 V ≤ Vs1 = Vs2 ≤ 18 V; -40°C ≤ Tj ≤ 150°C; unless otherwise specified.)

Symbol	Parameter	Conditions	Min	Typ	Max	Unit
<b>Digital Output RSTN</b>						
VoutL_RSTN	Low-level output voltage, low VR1/VS	VR1 > 4.7 V, I(RSTN) = 0.7 mA			0.4	V
		VR1 > 2 V, VS1 < VR1, I(RSTN) = 0.1 mA			0.4	
		VS1 > 2 V, I(RSTN) = 0.3 mA			0.4	
Rpullup_RSTN	Internal pull-up resistor to VR1		5	10	19	kΩ
<b>Digital Inputs TxDC, CAN_EN, WD_EN, HS_EN</b>						
VinL_pinx	Low-level input voltage (logical "Low")		0		0.8	V
VinH_pinx	High-level input voltage (logical "High")		2		VR1	V
Vin_hys_pinx	Input voltage hysteresis		100		500	mV
Rpullup_pinx	Internal pull-up resistor to VR1; pin TxDC		55	100	185	kΩ
Rpulldown_pinx	Internal pull-down resistor to ground; pins CAN_EN, HS_EN, WDI		55	100	185	kΩ
Ipullup_WD_EN	Internal pull-up current to VR1, pin WD_EN	V(WD_EN) = 0 V, pull-up current source active	50	100	200	μA
Tper_pullup_WDEN	WD_EN pull-up current source activation period	WD_EN = CAN_EN = HS_EN = Low		610		μs
Ton_pullup_WDEN	WD_EN pull-up current source activation on-time	WD_EN = CAN_EN = HS_EN = Low		5		μs
<b>Thermal Protection</b>						
Tsd1	Thermal shutdown level 1	Temperature increasing; HS switched off	145	155	165	°C
Tsd2	Thermal shutdown level 2	Temperature increasing; VR1 and CAN switched off	165	175	185	°C
Tsd1_off	Thermal shutdown recovery temperature	Temperature decreasing; HS switched on	135	145	155	°C

6. Not tested in production, guaranteed by design.

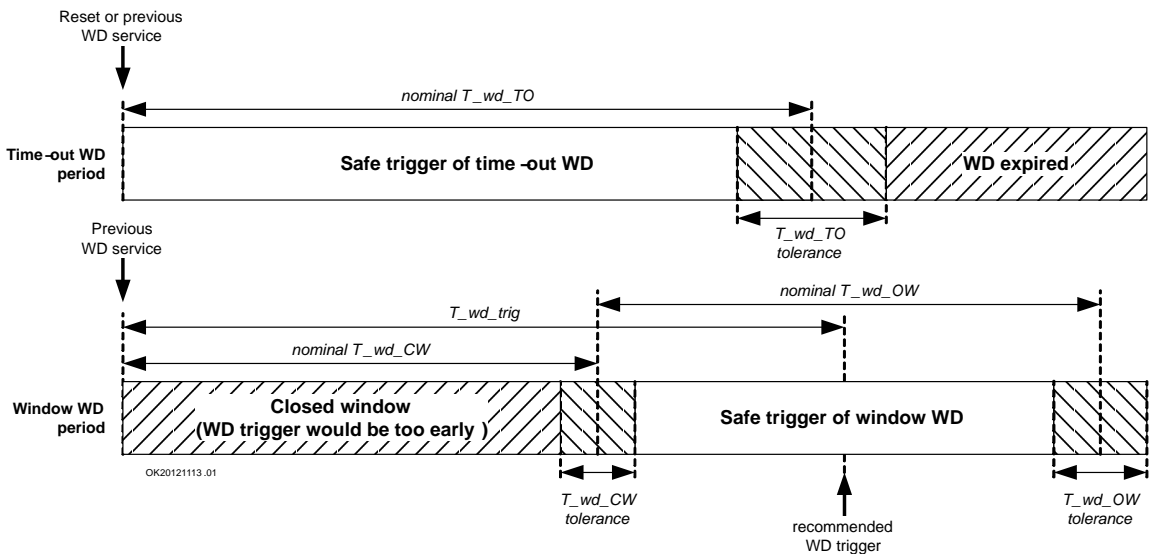

**Figure 2. Watchdog modes timing**

# NCV7450

**Table 6. ELECTRICAL CHARACTERISTICS (CONTINUED)**

(VR1 = 4.75 V to 5.25 V; T<sub>J</sub> = -40°C to +150°C; R<sub>LT</sub> = 60 Ω, C<sub>LT</sub> = 100 pF, C<sub>1</sub> not used unless specified otherwise.)

Symbol	Parameter	Conditions	Min.	Typ.	Max.	Unit
<b>CAN BUS LINES (Pins CANH and CANL)</b>						
I <sub>o(rec)</sub>	Recessive output current at pins CANH and CANL	CAN enabled; -27 V < V <sub>CANH/L</sub> < +32 V	-5	-	+5	mA
I <sub>LI</sub>	Input leakage current	0 ≤ R(VR1 to GND) < 1 MΩ V <sub>CANH</sub> = V <sub>CANL</sub> = 5 V	-5	0	+5	μA
V <sub>o(rec)</sub> (CANH)	Recessive output voltage at pin CANH	CAN enabled; V <sub>TxDC</sub> = VR1	2.0	2.5	3.0	V
V <sub>o(rec)</sub> (CANL)	Recessive output voltage at pin CANL	CAN enabled; V <sub>TxDC</sub> = VR1	2.0	2.5	3.0	V
V <sub>o(off)</sub> (CANH)	Recessive output voltage at pin CANH	CAN disabled	-0.1	0	0.1	V
V <sub>o(off)</sub> (CANL)	Recessive output voltage at pin CANL	CAN disabled	-0.1	0	0.1	V
V <sub>o(off)</sub> (diff)	Differential bus output voltage in off mode (V <sub>CANH</sub> - V <sub>CANL</sub> )	CAN disabled	-0.2	0	0.2	V
V <sub>o(dom)</sub> (CANH)	Dominant output voltage at pin CANH	50 Ω < R <sub>LT</sub> < 65 Ω; V <sub>TxDC</sub> = 0 V; t < t <sub>dom</sub> (TxDC)	2.75	3.5	4.5	V
V <sub>o(dom)</sub> (CANL)	Dominant output voltage at pin CANL	50 Ω < R <sub>LT</sub> < 65 Ω; V <sub>TxDC</sub> = 0 V; t < t <sub>dom</sub> (TxDC)	0.5	1.1	2.25	V
V <sub>o(dom)</sub> (sym)	Dominant output CANH/CANL drivers symmetry (V <sub>CANH</sub> + V <sub>CANL</sub> )	R <sub>LT</sub> = 60 Ω; C <sub>1</sub> = 4.7 nF; TxDC driven by square wave up to 1 MHz	0.9		1.1	VR1
V <sub>o(dom)</sub> (diff)	Differential bus output voltage (V <sub>CANH</sub> - V <sub>CANL</sub> )	V <sub>TxDC</sub> = 0 V; dominant; 45 Ω < R <sub>LT</sub> < 65 Ω	1.5	2.25	3.0	V
V <sub>o(dom)</sub> (diff)_arb	Differential bus output voltage during arbitration (V <sub>CANH</sub> - V <sub>CANL</sub> )	V <sub>TxDC</sub> = 0 V; dominant; R <sub>LT</sub> = 2240 Ω; (Note 7)	1.5		5	V
V <sub>o(rec)</sub> (diff)	Differential bus output voltage (V <sub>CANH</sub> - V <sub>CANL</sub> )	V <sub>TxDC</sub> = VR1; recessive; no load	-50	0	+50	mV
I <sub>o(sc)</sub> (CANH)	Short circuit output current at pin CANH	V <sub>CANH</sub> = -3 V; V <sub>TxDC</sub> = 0 V -3 V ≤ V <sub>CANH</sub> ≤ +18 V	-100 -100	-70	-40 1	mA
I <sub>o(sc)</sub> (CANL)	Short circuit output current at pin CANL	V <sub>CANL</sub> = 36 V; V <sub>TxDC</sub> = 0 V -3 V ≤ V <sub>CANL</sub> ≤ +18 V	40 -1	70	100 100	mA
V <sub>i(th)</sub> (diff)_NORM	Differential receiver threshold voltage in normal mode	CAN enabled; -12 V < V <sub>CANH</sub> < +12 V; -12 V < V <sub>CANL</sub> < +12 V	0.5	-	0.9	V
V <sub>i(rec)</sub> (diff)_NORM	Differential receiver input voltage for recessive state in normal mode	CAN enabled; -12 V < V <sub>CANH</sub> < +12 V; -12 V < V <sub>CANL</sub> < +12 V	-3	-	0.5	V
V <sub>i(dom)</sub> (diff)_NORM	Differential receiver input voltage for dominant state in normal mode	CAN enabled; -12 V < V <sub>CANH</sub> < +12 V; -12 V < V <sub>CANL</sub> < +12 V	0.9	-	8	V
V <sub>i(th)</sub> (diff)_WU	Differential receiver threshold voltage in wakeup-detection mode	CAN in wakeup-detection mode; -12 V < V <sub>CANH</sub> < +12 V; -12 V < V <sub>CANL</sub> < +12 V	0.4	-	1.05	V
V <sub>i(rec)</sub> (diff)_WU	Differential receiver input voltage for recessive state in wakeup-detection mode	CAN in wakeup-detection mode; -12 V < V <sub>CANH</sub> < +12 V; -12 V < V <sub>CANL</sub> < +12 V	-3	-	0.4	V
V <sub>i(dom)</sub> (diff)_WU	Differential receiver input voltage for dominant state in wakeup-detection mode	CAN in wakeup-detection mode; -12 V < V <sub>CANH</sub> < +12 V; -12 V < V <sub>CANL</sub> < +12 V	1.05	-	8	V
R <sub>i(cm)</sub> (CANH)	Common-mode input resistance at pin CANH	-2 V ≤ V <sub>CANH</sub> ≤ +7 V; -2 V ≤ V <sub>CANL</sub> ≤ +7 V	15	25	37	kΩ

# NCV7450

**Table 6. ELECTRICAL CHARACTERISTICS (CONTINUED)**

(VR1 = 4.75 V to 5.25 V; T<sub>J</sub> = -40°C to +150°C; R<sub>LT</sub> = 60 Ω, C<sub>LT</sub> = 100 pF, C<sub>1</sub> not used unless specified otherwise.)

Symbol	Parameter	Conditions	Min.	Typ.	Max.	Unit
<b>CAN BUS LINES (Pins CANH and CANL)</b>						
R <sub>i(cm)</sub> (CANL)	Common-mode input resistance at pin CANL	-2 V ≤ V <sub>CANH</sub> ≤ +7 V; -2 V ≤ V <sub>CANL</sub> ≤ +7 V	15	25	37	kΩ
R <sub>i(cm)</sub> (m)	Matching between pin CANH and pin CANL common mode input resistance	V <sub>CANH</sub> = V <sub>CANL</sub> = 5 V	-1	0	+1	%
R <sub>i(diff)</sub>	Differential input resistance	-2 V ≤ V <sub>CANH</sub> ≤ +7 V; -2 V ≤ V <sub>CANL</sub> ≤ +7 V	25	50	75	kΩ
C <sub>i(CANH)</sub>	Input capacitance at pin CANH	V <sub>TxDC</sub> = VR1; (Note 7)	-	7.5	20	pF
C <sub>i(CANL)</sub>	Input capacitance at pin CANL	V <sub>TxDC</sub> = VR1; (Note 7)	-	7.5	20	pF
C <sub>i(diff)</sub>	Differential input capacitance	V <sub>TxDC</sub> = VR1; (Note 7)	-	3.75	10	pF
<b>TIMING CHARACTERISTICS (see Figure 3 and Figure 4)</b>						
t <sub>d(TxDC-BUSon)</sub>	Delay TxDC to bus dominant		-	65	-	ns
t <sub>d(TxDC-BUSoff)</sub>	Delay TxDC to bus recessive		-	90	-	ns
t <sub>d(BUSon-RxDC)</sub>	Delay bus dominant to RxDC		-	60	-	ns
t <sub>d(BUSoff-RxDC)</sub>	Delay bus recessive to RxDC		-	65	-	ns
t <sub>pd_dr</sub>	Propagation delay TxDC to RxDC dominant to recessive transition		50	100	210	ns
t <sub>pd_rd</sub>	Propagation delay TxDC to RxDC recessive to dominant transition		50	120	210	ns
t <sub>d(stb-nm)</sub>	Delay wake-up detection mode to normal mode		7	25	47	μs
t <sub>wake_filt</sub>	Dominant time for wake-up via bus		0.15	-	1.8	μs
t <sub>dwakerd</sub>	Delay to flag wake event (recessive to dominant transitions)	Valid bus wake-up event	0.5	-	10	μs
t <sub>dwakedr</sub>	Delay to flag wake event (dominant to recessive transitions)	Valid bus wake-up event	0.5	-	10	μs
t <sub>wake_to</sub>	Bus time for wake-up timeout	CAN_EN = low	1	-	10	ms
t <sub>dom(TxDC)</sub>	TxDC dominant time for timeout	CAN_EN = high; V <sub>TxDC</sub> = 0 V	1	-	10	ms
t <sub>Bit(RxDC)</sub>	Bit time on RxDC pin	t <sub>Bit(TxDC)</sub> = 500 ns	400	-	550	ns
		t <sub>Bit(TxDC)</sub> = 200 ns	120	-	220	ns
t <sub>Bit(Vi(diff))</sub>	Bit time on bus (CANH - CANL pin)	t <sub>Bit(TxDC)</sub> = 500 ns	435	-	530	ns
		t <sub>Bit(TxDC)</sub> = 200 ns	155	-	210	ns
Δt <sub>Rec</sub>	Receiver timing symmetry Δt <sub>Rec</sub> = t <sub>Bit(RxDC)</sub> - t <sub>Bit(Vi(diff))</sub>	t <sub>Bit(TxDC)</sub> = 500 ns	-65	-	40	ns
		t <sub>Bit(TxDC)</sub> = 200 ns	-45	-	15	ns

7. Not tested in production, guaranteed by design.



# NCV7450

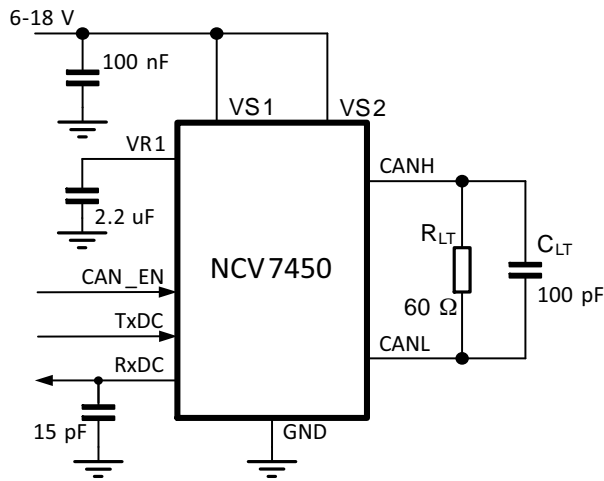

Figure 3. Test Circuit for Timing Characteristics

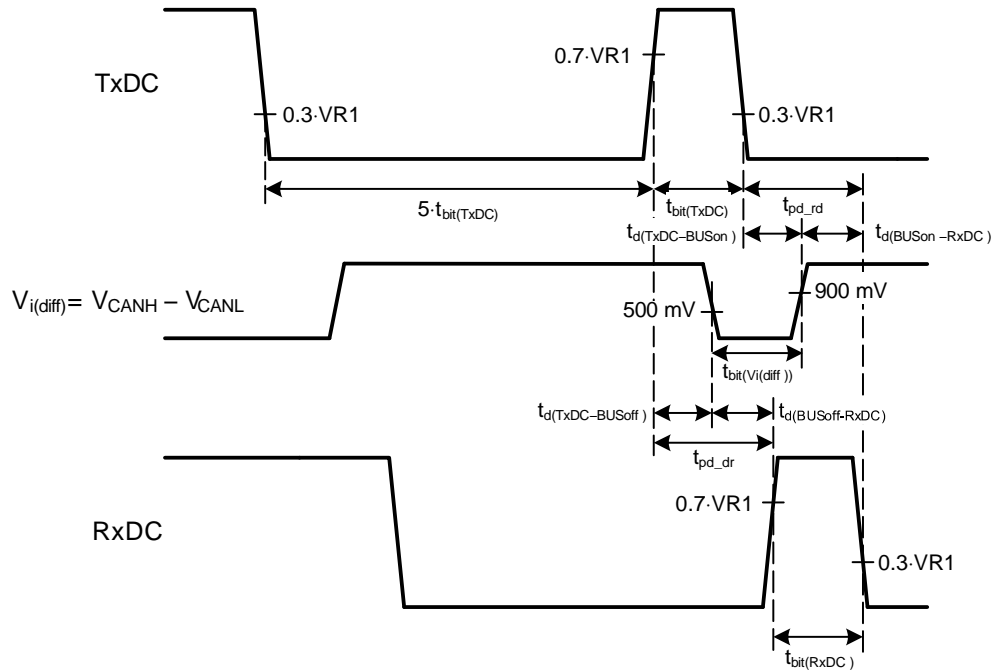

Figure 4. CAN Transceiver Timing Diagram

FUNCTIONAL DESCRIPTION

Supply Concept

The device has two independent supply pins VS1 and VS2. While VR1 regulator and logic control are supplied from VS1, High-side driver is supplied from VS2. Both supply lines have to be properly decoupled by filtration capacitors close to the device pins.

As long as VS1 < VS\_POR level, all the blocks are in power-down mode.

VR1 Low-drop Regulator

VR1 is a low-drop output regulator providing 5 V voltage derived from the VS1 main supply. It is able to deliver up to 250 mA and is primarily intended to supply the on-chip CAN transceiver, the application microcontroller unit (MCU) and related 5 V loads (e.g. its own MCU-related digital inputs/outputs). An external capacitor needs to be connected on VR1 pin in order to ensure the regulator's stability and to filter the disturbances caused by the connected loads.

VR1 voltage is supplying all the digital low-voltage input/output pins.

The protection and monitoring of the VR1 regulator consist of the following features:

- ◆ ·VR1 Current Limitation – the two-level current limitation controlled by VR1 reset comparator to reduce the power dissipation in case of shorts to ground by the current fold-back (see Figure 6)
- ◆ ·VR1 Reset Comparator – the VR1 regulator output is compared with a reset level RES\_VR1. If the VR1 level drops below this level for longer than *Tflt\_RES\_VR1*, a reset towards the MCU is generated through the RSTN pin and peripherals (CAN transceiver and HS driver) disabled.
- ◆ ·Temperature (see Figure 14)

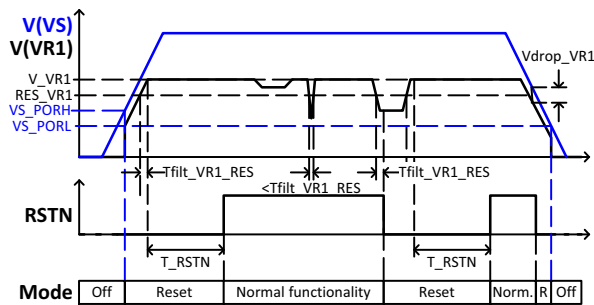

Figure 5. VR1 monitoring

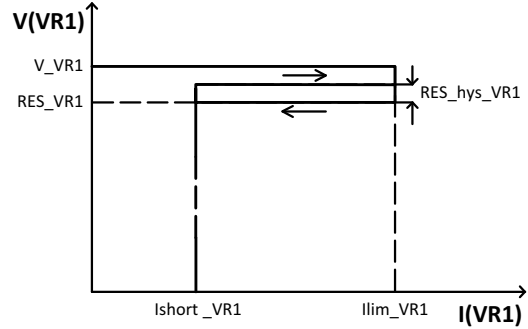

Figure 6. VR1 current fold-back

CAN Transceiver

The SBC contains one high-speed CAN transceiver compliant with ISO11898-2:2016. The transceiver consists of the following sub-blocks: transmitter, receiver, and wakeup detector.

If enabled (CAN\_EN = High), the CAN transceiver is ready to provide the full-speed interface between the bus and a CAN controller connected on pins RxDC (received data) and TxDC (data to transmit).

In order to prevent a faulty node from blocking the bus traffic, the maximum length of the transmitted dominant symbol is limited by a time-out counter to *t\_TxDC\_timeout*. In case the TxDC Low signal exceeds the timeout value, the transmitter returns automatically to the recessive state. The transmission is again de-blocked when TxDC pin returns to high (recessive) state.

If the CAN block is disabled (CAN\_EN = Low), the CAN transceiver is in its wake-up detection state. The bus lines are biased to ground. Logical level on TxDC is ignored and pin RxDC is kept high until a CAN bus wake-up is detected. The CAN bus wake-up corresponds to a pattern consisting of dominant – recessive – dominant symbols of at least *t\_wake\_filt* each. The RxDC starts following the CAN bus afterwards. The pattern must be received within *t\_wake\_to* to be recognized as a valid wake-up event, otherwise internal wake-up logic is reset.

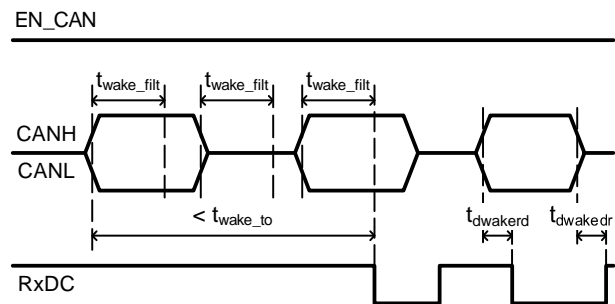

Figure 7. CAN wakeup pattern

**HS Driver**

HS high-side driver is intended to drive an external load. Its state is directly controlled via HS\_EN pin and diagnostics are flagged on HS\_DIAG pin (see Table 7).

When the driver is enabled (HS\_EN = High), it is protected against an excessive current and temperature and diagnosed on under-load condition.

In case the HS driver is controlled by a PWM signal through HS\_EN with very low duty-cycle, the diagnostic

features are limited by  $td_{oc\_HS}$  in case of an over-current and  $(VS2 / dVout\_HS) + td_{uld\_HS}$  in case of an underload.

The HS driver is designed to drive resistive loads. Therefore only a limited clamping energy ( $W < 1 \text{ mJ}$ ) can be dissipated by the device. For inductive loads ( $L > 100 \mu\text{H}$ ) an external freewheeling diode connected between GND and the HS pin is required.

**Table 7. HS Driver Diagnostics**

Event	HS_EN	Failure condition	HS status	HS_DIAG	Recovery condition
Normal operation (no failure)	Low	–	Off	High	–
	High	–	On	High	–
Over-current	High	$I(HS) > I_{oc\_HS}$	Off	Low	HS_EN = Low
Under-load	High	$I(HS) < I_{uld\_HS}$	On	Low	$I(HS) > I_{uld\_HS}$
Short-to-battery					
Over-temperature	High	$T_j > T_{sd1}$	Off	Low	$T_j < T_{sd1\_off}$
VS2 Over-voltage	High	$VS2 > VS2\_OV$	Off	Low	$VS2 < VS2\_OV$
RSTN active	High	RSTN = Low	Off	Low	RSTN = High

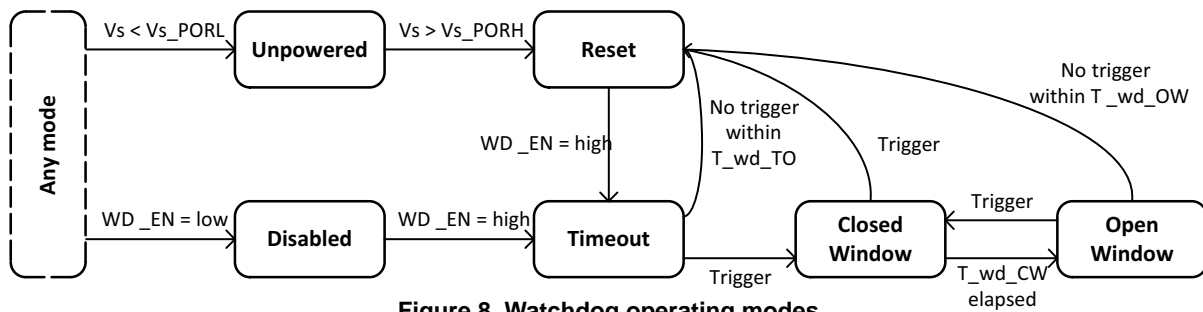
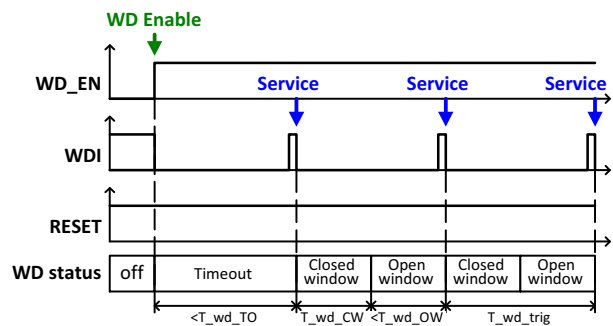

**Figure 8. Watchdog operating modes**

**Watchdog**

The on-chip watchdog requires that the MCU software “triggers” or “services” the watchdog in a specified time frame. A correct watchdog service consists of high-to-low transition on the WDI input. The watchdog timer re-starts immediately after a successful trigger is received.

After any Reset event (power-up, watchdog failure, VR1 undervoltage, thermal shutdown 2) or watchdog enable (WD\_EN = Low → High), the watchdog always starts in a timeout mode. The MCU software must serve the watchdog any time before the time-out expiration. After the watchdog is triggered for the first time, it starts working in a window mode operation: the watchdog time is split to two distinct parts – a closed window, where the watchdog may not be triggered, is followed by an open window where the MCU must send a valid watchdog trigger (see Figure 9).



**Figure 9. Correct watchdog services**

In case the watchdog is not triggered before the timeout or open window elapses (Figure 10, Figure 11), or trigger is sent within the closed window (Figure 12), RSTN signal is generated and then watchdog restarted in the timeout mode again.

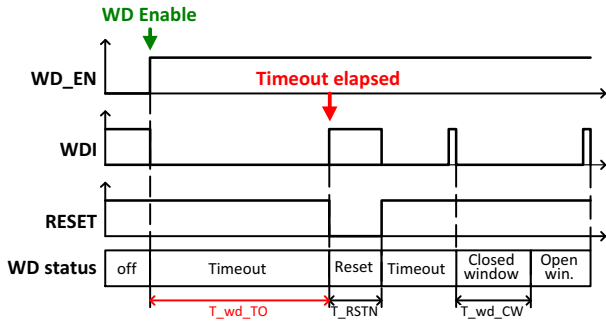

Figure 10. Missed watchdog in Timeout mode

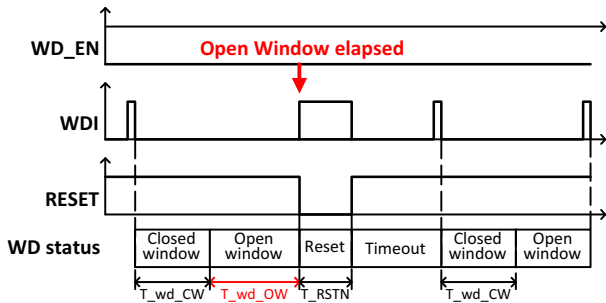

Figure 11. Missed watchdog in Window mode

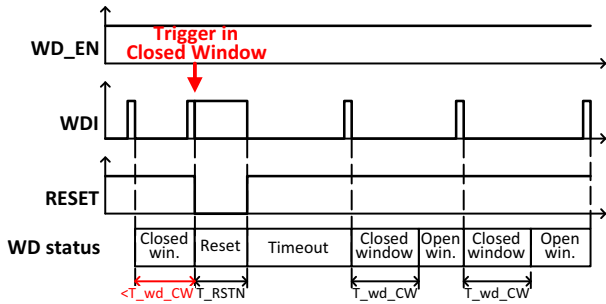

Figure 12. Watchdog service during closed window

The WD\_EN pin has an integrated pull-up source to enable the watchdog in case the pin is disconnected from the application. To reduce the power consumption in the low-power mode (watchdog, CAN and HS driver disabled), the WD\_EN pull-up current source is switched on for  $T_{on\_pullup\_WDEN}$  time with period of  $T_{per\_pullup\_WDEN}$ . The pin state is sampled in the end of the current source activation. Once High level is detected on the WD\_EN pin, the current source is activated permanently.

To ensure the High level is correctly detected if the pin becomes floating, external WD\_EN capacity should stay below 50 pF.

After the rising edge on WD\_EN pin, the MCU should wait  $T_{per\_pullup\_WDEN}$  before the first watchdog service.

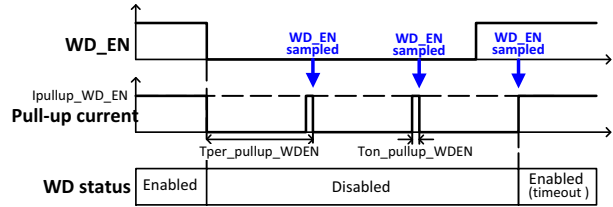

Figure 13. WD\_EN pull-up current source activation

**Thermal Protection**

The device junction temperature is monitored in order to avoid permanent degradation or damage. Two distinct junction temperature levels are provided – thermal shutdown level 1  $T_{sd1}$  (typ. 155°C) and thermal shutdown level 2  $T_{sd2}$  (typ. 175°C).

When the junction temperature exceeds the first thermal shutdown level, the high-side driver is disabled while VR1 and CAN transceiver keeps running so that the MCU can still take appropriate actions. The junction temperature above the second shutdown level leads to complete device de-activation, VR1 included; the device recovers automatically after the junction temperature drops below  $T_{sd1}$  level and  $T_{off\_VR1}$  (typ. 1 second) elapses. HS driver functionality is recovered when the junction temperature drops below  $T_{sd1\_off}$ .

The details of the thermal protection handling are shown in Figure 14.

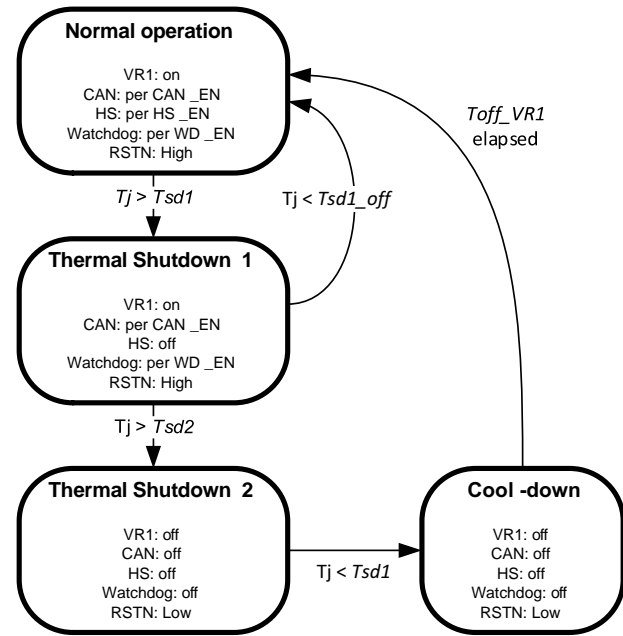

Figure 14. Thermal monitoring flow chart

Table 8. ISO11898–2:2016 parameter cross–reference table

ISO 11898–2:2016 Specification		NCV7450 Datasheet
Parameter	Notation	Symbol
<b>Dominant output characteristics</b>		
Single ended voltage on CAN_H	$V_{CAN\_H}$	$V_{o(dom)}(CANH)$
Single ended voltage on CAN_L	$V_{CAN\_L}$	$V_{o(dom)}(CANL)$
Differential voltage on normal bus load	$V_{Diff}$	$V_{o(dom)}(diff)$
Differential voltage on effective resistance during arbitration	$V_{Diff}$	$V_{o(dom)}(diff\_arb)$
Optional: Differential voltage on extended bus load range	$V_{Diff}$	$V_{o(dom)}(diff)$
<b>Driver symmetry</b>		
Driver symmetry	$V_{SYM}$	$V_{o(dom)}(sym)$
<b>Driver output current</b>		
Absolute current on CAN_H	$I_{CAN\_H}$	$I_{o(SC)}(CANH)$
Absolute current on CAN_L	$I_{CAN\_L}$	$I_{o(SC)}(CANL)$
<b>Receiver output characteristics, bus biasing active</b>		
Single ended output voltage on CAN_H	$V_{CAN\_H}$	$V_{o(rec)}(CANH)$
Single ended output voltage on CAN_L	$V_{CAN\_L}$	$V_{o(rec)}(CANL)$
Differential output voltage	$V_{Diff}$	$V_{o(rec)}(diff)$
<b>Receiver output characteristics, bus biasing inactive</b>		
Single ended output voltage on CAN_H	$V_{CAN\_H}$	$V_{o(off)}(CANH)$
Single ended output voltage on CAN_L	$V_{CAN\_L}$	$V_{o(off)}(CANL)$
Differential output voltage	$V_{Diff}$	$V_{o(off)}(dif)$
<b>Optional transmit dominant timeout</b>		
Transmit dominant timeout, long	$t_{dom}$	$T_{dom}(TxDC)$
Transmit dominant timeout, short	$t_{dom}$	NA
<b>Static receiver input characteristics, bus biasing active</b>		
Recessive state differential input voltage range	$V_{Diff}$	$V_{i(rec)}(diff) \_ NORM$
Dominant state differential input voltage range	$V_{Diff}$	$V_{i(dom)}(diff) \_ NORM$
<b>Static receiver input characteristics, bus biasing inactive</b>		
Recessive state differential input voltage range	$V_{Diff}$	$V_{i(rec)}(diff) \_ WU$
Dominant state differential input voltage range	$V_{Diff}$	$V_{i(dom)}(diff) \_ WU$
<b>Receiver input resistance</b>		
Differential internal resistance	$R_{Diff}$	$R_{i(diff)}$
Single ended internal resistance	$R_{CAN\_H}$ $R_{CAN\_L}$	$R_{i(cm)}(CANH)$ $R_{i(cm)}(CANL)$
<b>Receiver input resistance matching</b>		
Matching a of internal resistance	$m_R$	$R_{i(cm)}(m)$
<b>Implementation loop delay requirement</b>		
Loop delay	$t_{Loop}$	$t_{pd\_rd}$ $t_{pd\_dr}$
<b>Optional implementation data signal timing requirements for use with bit rates above 1 Mbit/s and up to 2 Mbit/s</b>		
Transmitted recessive bit width @ 2 Mbit/s	$t_{Bit}(Bus)$	$t_{Bit}(Vi(diff))$
Received recessive bit width @ 2 Mbit/s	$t_{Bit}(RXD)$	$t_{Bit}(RxD)$
Receiver timing symmetry @ 2 Mbit/s	$\Delta t_{Rec}$	$\Delta t_{Rec}$

Table 8. ISO11898–2:2016 parameter cross–reference table

Parameter	Notation	Symbol
<b>Optional implementation data signal timing requirements for use with bit rates above 2 Mbit/s and up to 5 Mbit/s</b>		
Transmitted recessive bit width @ 5 Mbit/s	$t_{\text{Bit(Bus)}}$	$t_{\text{Bit(Vi(diff))}}$
Transmitted recessive bit width @ 5 Mbit / s	$t_{\text{Bit(RxD)}}$	$t_{\text{Bit(RxD)}}$
Received recessive bit width @ 5 Mbit / s	$\Delta t_{\text{Rec}}$	$\Delta t_{\text{Rec}}$
<b>Maximum ratings of <math>V_{\text{CAN\_H}}</math>, <math>V_{\text{CAN\_L}}</math> and <math>V_{\text{Diff}}</math></b>		
Maximum rating $V_{\text{Diff}}$	$V_{\text{Diff}}$	$V_{\text{max\_diff}}$
General maximum rating $V_{\text{CAN\_H}}$ and $V_{\text{CAN\_L}}$	$V_{\text{CAN\_H}}$ $V_{\text{CAN\_L}}$	$V_{\text{CANH}}$ $V_{\text{CANL}}$
Optional: Extended maximum rating $V_{\text{CAN\_H}}$ and $V_{\text{CAN\_L}}$	$V_{\text{CAN\_H}}$ $V_{\text{CAN\_L}}$	NA
<b>Maximum leakage currents on CAN_H and CAN_L, unpowered</b>		
Leakage current on CAN_H, CAN_L	$I_{\text{CAN\_H}}$ , $I_{\text{CAN\_L}}$	$I_{\text{LI}}$
<b>Bus biasing control timings</b>		
CAN activity filter time, long	$t_{\text{Filter}}$	NA
CAN activity filter time, short	$t_{\text{Filter}}$	$t_{\text{wake\_filt}}$
Optional: Wake–up timeout, short	$t_{\text{Wake}}$	$t_{\text{wake\_to}}$
Optional: Wake–up timeout, long	$t_{\text{Wake}}$	$t_{\text{wake\_to}}$
Timeout for bus inactivity (Required for selective wake–up implementation only)	$t_{\text{Silence}}$	NA
Bus Bias reaction time (Required for selective wake–up implementation only)	$t_{\text{Bias}}$	NA

# NCV7450

## PACKAGE DIMENSIONS

### TSSOP16, 4.4x5 EXPOSED PAD CASE 948BV ISSUE O

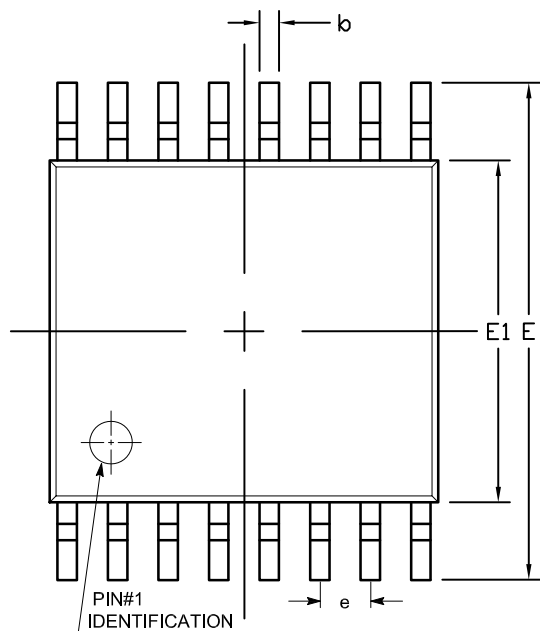

TOP VIEW

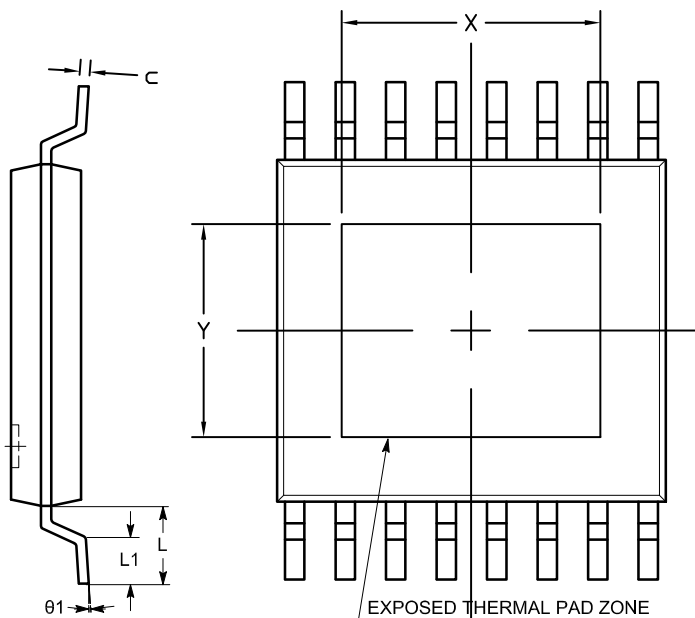

END VIEW

BOTTOM VIEW

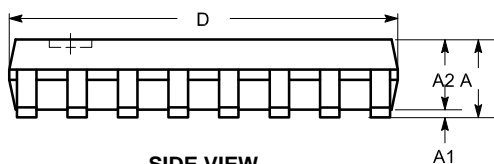

SIDE VIEW

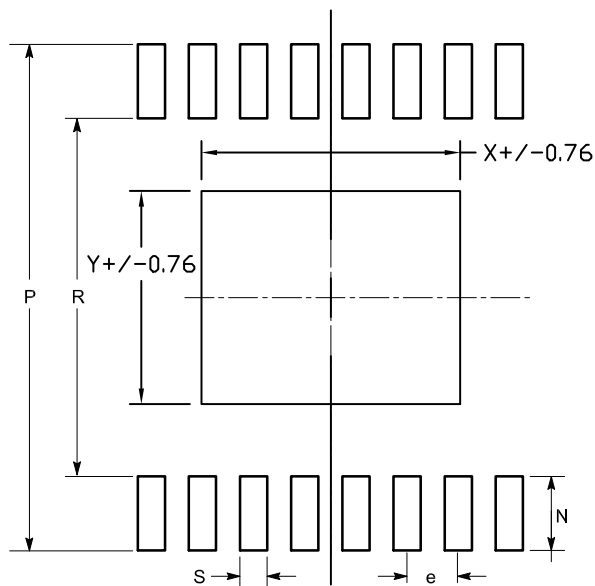

LAND PATTERN

SYMBOL	MIN	NOM	MAX
A			1.10
A1	0.05		0.15
A2	0.85		0.95
b	0.19		0.30
c	0.13		0.20
D	4.90		5.10
E	6.30		6.50
E1	4.30		4.50
e	0.65 BSC		
L	1.00 REF		
L1	0.45		0.75
N	0.90		1.00
P	6.50		6.70
R	4.60		4.80
S	0.37		0.47
theta	0°		8°
X		3.33 REF	
Y		2.76 REF	

**Notes:**

- (1) All dimensions are in millimeters. Angles in degrees.
- (2) Complies with JEDEC MO-153 variations ABT.

ON Semiconductor and  are trademarks of Semiconductor Components Industries, LLC dba ON Semiconductor or its subsidiaries in the United States and/or other countries. ON Semiconductor owns the rights to a number of patents, trademarks, copyrights, trade secrets, and other intellectual property. A listing of ON Semiconductor's product/patent coverage may be accessed at [www.onsemi.com/site/pdf/Patent-Marking.pdf](http://www.onsemi.com/site/pdf/Patent-Marking.pdf). ON Semiconductor reserves the right to make changes without further notice to any products herein. ON Semiconductor makes no warranty, representation or guarantee regarding the suitability of its products for any particular purpose, nor does ON Semiconductor assume any liability arising out of the application or use of any product or circuit, and specifically disclaims any and all liability, including without limitation special, consequential or incidental damages. Buyer is responsible for its products and applications using ON Semiconductor products, including compliance with all laws, regulations and safety requirements or standards, regardless of any support or applications information provided by ON Semiconductor. "Typical" parameters which may be provided in ON Semiconductor data sheets and/or specifications can and do vary in different applications and actual performance may vary over time. All operating parameters, including "Typicals" must be validated for each customer application by customer's technical experts. ON Semiconductor does not convey any license under its patent rights nor the rights of others. ON Semiconductor products are not designed, intended, or authorized for use as a critical component in life support systems or any FDA Class 3 medical devices or medical devices with a same or similar classification in a foreign jurisdiction or any devices intended for implantation in the human body. Should Buyer purchase or use ON Semiconductor products for any such unintended or unauthorized application, Buyer shall indemnify and hold ON Semiconductor and its officers, employees, subsidiaries, affiliates, and distributors harmless against all claims, costs, damages, and expenses, and reasonable attorney fees arising out of, directly or indirectly, any claim of personal injury or death associated with such unintended or unauthorized use, even if such claim alleges that ON Semiconductor was negligent regarding the design or manufacture of the part. ON Semiconductor is an Equal Opportunity/Affirmative Action Employer. This literature is subject to all applicable copyright laws and is not for resale in any manner.

## PUBLICATION ORDERING INFORMATION

### LITERATURE FULFILLMENT:

Literature Distribution Center for ON Semiconductor  
19521 E. 32nd Pkwy, Aurora, Colorado 80011 USA  
**Phone:** 303-675-2175 or 800-344-3860 Toll Free USA/Canada  
**Fax:** 303-675-2176 or 800-344-3867 Toll Free USA/Canada  
**Email:** [orderlit@onsemi.com](mailto:orderlit@onsemi.com)

**N. American Technical Support:** 800-282-9855 Toll Free  
USA/Canada  
**Europe, Middle East and Africa Technical Support:**  
Phone: 421 33 790 2910

**ON Semiconductor Website:** [www.onsemi.com](http://www.onsemi.com)

**Order Literature:** <http://www.onsemi.com/orderlit>

For additional information, please contact your local Sales Representative