

DK relay socket



TYPES AND RELAY COMPATIBILITY

| Relay | | Socket | 1 Form A | | 1 Form A 1 Form B, 2 Form A | |
|----------------------------|-------------------------|--------|-------------------------|----------------------|-----------------------------|----------------------|
| | | | Single side stable type | 2 coil latching type | Single side stable type | 2 coil latching type |
| 1 Form A | Single side stable type | | DK1a-PS | DK1a-PSL2 | — | — |
| | 2 coil latching type | | — | DK1a-PSL2 | — | — |
| 1 Form A 1 Form B 2 Form A | Single side stable type | | — | — | DK2a-PS | DK2a-PSL2 |
| | 2 coil latching type | | — | — | — | DK2a-PSL2 |

SPECIFICATIONS

| | |
|-------------------------|--|
| Breakdown voltage*1 | 4,000 Vrms (Except the portion between coil terminals) |
| Insulation resistance | Min. 1,000 mΩ (at 500 V DC) |
| Heat resistance | 150°C (for 1 hour) |
| Max. continuous current | 10 A (DK1a-PS, DK1a-PSL2), 8 A (DK2a-PS, DK2a-PSL2) |

Remarks

*1 Detection current: 10 mA

DIMENSIONS

mm inch

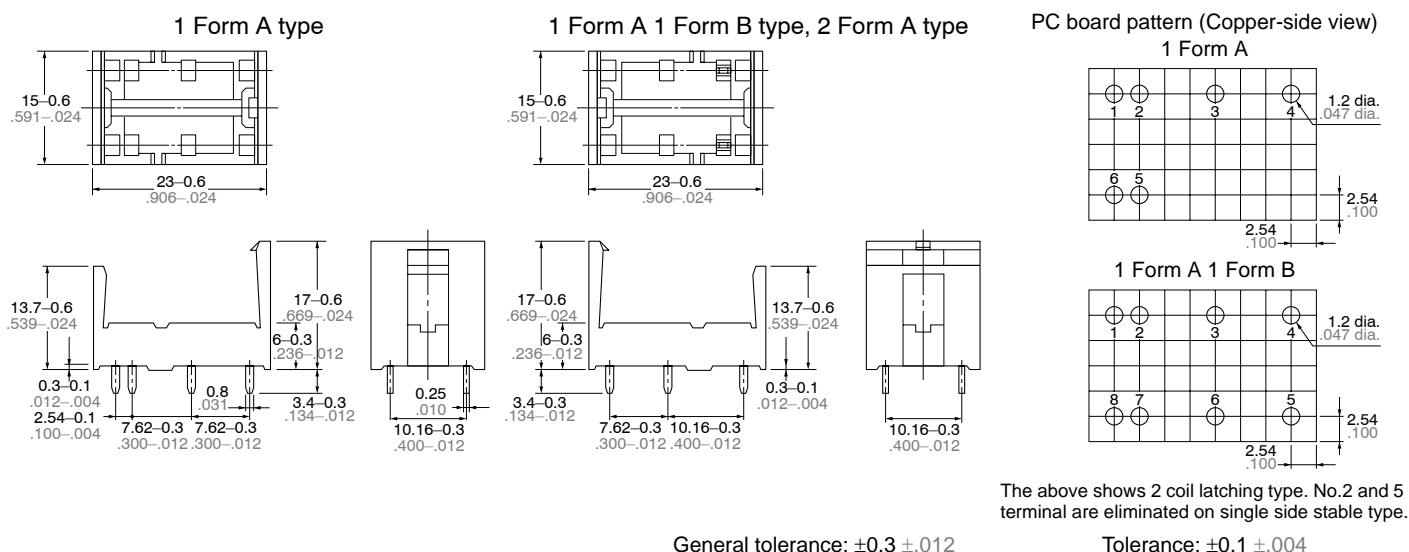

FIXING AND REMOVAL METHOD

1. Match the direction of relay and socket.
2. Both ends of the relay are to be secured firmly so that the socket hooks on the top surface of the relay.
3. Remove the relay, applying force in the direction shown below.
4. In case there is not enough space to grasp relay with fingers, use screwdrivers in the way shown below.

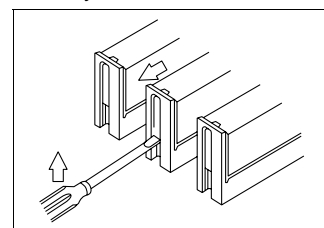
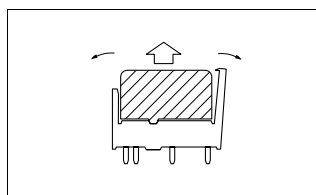
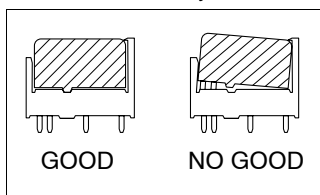
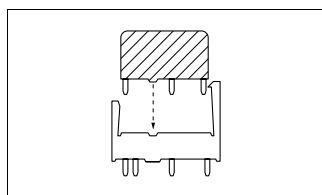

NOTES

1. Phase synchronization of AC-load switching
In case of switching the contact synchronized with phase of load voltage, the life of contact might be shorter or contact failure might be caused. Please confirm this matter in the actual system in this case. If necessary, the phase control would be recommended.

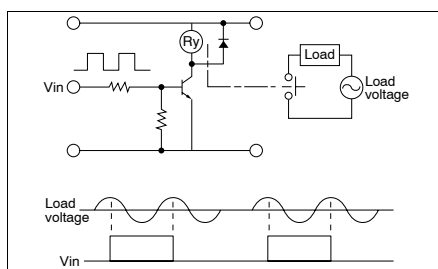

2. Soldering should be done under the following conditions:
250°C 482°F within 10s
300°C 572°F within 5s
350°C 662°F within 3s

For Cautions for Use, see [Relay Technical Information](#).