



Product Change Notification

Current Date: 15-Nov-2018

TE Connectivity

Product Change Notification: P-18-016546

PCN Date: 07-NOV-18

Customer: TTI Inc(0000139702)

Location: WORLDWIDE

Agreement: Agreement Unknown

TE would like to inform you of the following change(s) to the listed TE Connectivity Product. In case of any further questions about this change(s), please contact your TE Connectivity Sales Engineer. Affected part, drawing and/or specification numbers are listed on the attached sheet(s).

General Product Description:
AMP MCP 6.3/4.8K - Application Specification 114-18388

Description of Changes
New Application Specification version Rev G.; New PN s added (2333550, 2333551, 2333552, 2324131, 2324132 and 2327632); New crimp heights added to meet the requirements of Slow Motion Bending, PN 1241400 (0.22mm and 0.35mm) and PN 1241410 (0.35mm); Crimp height was changed for 1.0mm (1.52mm +/-0.05 to 1.54mm +/-0.03 on PN 1241402, 2208460 and 1241412) to improve the conductor pull out strength, still same maximum crimp height to meet the requirements of Slow Motion Bending;
Other attachments:
Application Specification 114-18388 Rev G

Reason for Changes:	
Part status change.	
Estimated Dates:	
Last Order Date (Obsolete Parts Only):	First Date To Ship (Changed Parts Only):

Last Ship Date (Obsolete Parts Only):	Last Date for Mixed Shipments: (Changed Parts Only):
	No Mixed Shipments

Part Number(s) being Modified:

Part Number	Part Discontinued per PCN	Customer Drawing	Customer Part Number	Alias Part Number(s)	Substitute Part Number	Substitute Alias Part Number(s)	Description Of Difference
1241402-1	NO						
1241402-3	NO						
1241404-1	NO						
1241404-3	NO						
1241406-1	NO						
1241408-1	NO						
1241412-1	NO						
1241414-1	NO						
1241416-1	NO						
1241418-4	NO						
2-1241408-3	NO						

The documents listed below are being modified. Related parts that are not explicitly listed on this PCN are not being modified or discontinued as per the PCN. The Last Order Date, Last Ship Date, First Date to Ship Changed Parts and last date for Mixed Shipments apply only to parts explicitly listed on this PCN.

Document(s) Being Modified:

Documents Number	Related Part Number	Customer Part Number	Current Revision	New Revision
114-18388	1241402-1, 1241406-1		G	

Customer: TTI Electronics Asia Pte Ltd. (1407161)

Location: Kowloon Bay

Agreement Number: Agreement Unknown

Part Number(s) being Modified:

Part Number	Part Discontinued per PCN	Customer Drawing	Customer Part Number	Alias Part Number(s)	Substitute Part Number	Substitute Alias Part Number(s)	Description Of Difference
1241404-1	NO						

Customer: TTI Inc (1281288)

Location: Fort Worth

Agreement Number: Agreement Unknown

Part Number(s) being Modified:

Part Number	Part Discontinued per PCN	Customer Drawing	Customer Part Number	Alias Part Number(s)	Substitute Part Number	Substitute Alias Part Number(s)	Description Of Difference
1241406-1	NO						
1241414-1	NO						
1241416-1	NO						
1241418-4	NO						

The documents listed below are being modified. Related parts that are not explicitly listed on this PCN are not being modified or discontinued as per the PCN. The Last Order Date, Last Ship Date, First Date to Ship Changed Parts and last date for Mixed Shipments apply only to parts explicitly listed on this PCN.

Document(s) Being Modified:

Documents Number	Related Part Number	Customer Part Number	Current Revision	New Revision
114-18388	1241406-1		G	

Customer: TTI Inc. (1305175)

Location: Maisach-gernlinden

Agreement Number: TTI001

Part Number(s) being Modified:

Part Number	Part Discontinued per PCN	Customer Drawing	Customer Part Number	Alias Part Number(s)	Substitute Part Number	Substitute Alias Part Number(s)	Description Of Difference
1241402-1	NO		TYC1241402-1				
1241402-3	NO						

1241404-1	NO		TYC1241404-1				
1241404-3	NO		TYC1241404-3				
1241406-1	NO		TYC1241406-1				
1241408-1	NO		TYC1241408-1				
1241412-1	NO		TYC1241412-1				
1241414-1	NO		TYC1241414-1				
1241416-1	NO		TYC1241416-1				
1241418-4	NO		TYC1241418-4				
2-1241408-3	NO						

The documents listed below are being modified. Related parts that are not explicitly listed on this PCN are not being modified or discontinued as per the PCN. The Last Order Date, Last Ship Date, First Date to Ship Changed Parts and last date for Mixed Shipments apply only to parts explicitly listed on this PCN.

Document(s) Being Modified:

Documents Number	Related Part Number	Customer Part Number	Current Revision	New Revision
114-18388	1241402-1	TYC1241402-1	G	

Customer: TTI Inc (168830)

Location: Fort Worth

Agreement Number: Agreement Unknown

Part Number(s) being Modified:

Part Number	Part Discontinued per PCN	Customer Drawing	Customer Part Number	Alias Part Number(s)	Substitute Part Number	Substitute Alias Part Number(s)	Description Of Difference
1241406-1	NO						
1241414-1	NO						
1241416-1	NO						
1241418-4	NO						

Customer: TTI Inc. (3057778)

Location: Maisach-gernlinden

Agreement Number: Agreement Unknown

Part Number(s) being Modified:

Part Number	Part Discontinued per PCN	Customer Drawing	Customer Part Number	Alias Part Number(s)	Substitute Part Number	Substitute Alias Part Number(s)	Description Of Difference
1241402-3	NO						
1241404-1	NO		TYC1241404-1				
1241404-3	NO		TYC1241404-3				
1241406-1	NO		TYC1241406-1				
1241412-1	NO		TYC1241412-1				
1241416-1	NO		TYC1241416-1				
1241418-4	NO		TYC1241418-4				
2-1241408-3	NO						



AMP MCP6.3/4.8K CONTACT SYSTEM AMP MCP6.3/4.8K Kontaktsystem

Contents	Page	Inhaltsverzeichnis	Seite
1. SCOPE	2	1. ZWECK	2
2. REFERENCED DOCUMENTS	2	2. ZUSÄTZLICHE UNTERLAGEN	2
2.1 Customer drawings	2	2.1 Kundenzeichnungen	2
2.2 Product specifications	2	2.2 Produktspezifikationen	2
2.3 Application specifications	2	2.3 Verarbeitungsspezifikationen	2
2.4 Customer information	2	2.4 Kundenbroschüren	2
2.5 National / international standards	2	2.5 Nationale / Internationale Normen	2
3. DESCRIPTION	3	3. BESCHREIBUNG	3
3.1 Contacts with insulation crimp	3	3.1 Kontakte mit Isolationscrimp	3
3.2 Contacts with crimp for single wire seal	4	3.2 Kontakte mit Crimp für Einzelleiterdichtung	4
4. REQUIREMENTS	5	4. ANFORDERUNGEN	5
4.1 Cables	5	4.1 Leitungen	5
4.2 Cut off and burr	5	4.2 Trennsteg und Grat	5
4.3 Conductor crimp	5	4.3 Drahtcrimp	5
4.4 Insulation crimp / crimp for single wire seal	5	4.4 Isolationscrimp / Crimp für Einzelleiterdichtung	5
4.5 Contact body	6	4.5 Kontaktkörper	6
4.6 Shape and position tolerances of the crimped contact	6	4.6 Form- und Lagetoleranzen des gecrimpten Kontaktes	6
5. CRIMPING DATA	8	5. CRIMPDATEN	8
Table 1: Contacts with insulation crimp	8	Tabelle 1: Kontakte mit Isolationscrimp	8
Table 2: Contacts with crimp for single wire seal	9	Tabelle 2: Kontakte mit Crimp für Einzelleiterdichtung	9
Table 3: Single wire seals	10	Tabelle 3: Einzelleiterdichtungen	10
6. DEAD END PLUGS ASSEMBLY	10	6. MONTAGE VON BLINDSTOPFEN	10
7. AUXILIARY TOOLS	11	7. HILFSWERKZEUGE	11
7.1 Extraction tool	11	7.1 Ausdrückwerkzeug	11
7.2 Assembly tool	11	7.2 Montagehilfe	11



1. SCOPE

This specification covers the special guidelines for the application of the **AMP MCP6.3/4.8K contact system**.

Only specified TE crimp tools have to be used for application of contacts.

2. REFERENCED DOCUMENTS

2.1 Customer drawings

The customer drawing **1241438** shows the dimensions and materials for each part number. In the case of a conflict between this document and the customer drawing, the customer drawing takes precedence.

2.2 Product specifications

The electrical and mechanical attributes of the contacts are defined in product specification **108-18718** for application with Tabs as far as **108-94427** for application with Type C Fuses (MEDIUM).

In case of conflict, these take precedence over the general guidelines contained in this specification.

2.3 Application specifications

The general guidelines laid down in application specifications **114-18022** and **114-18018** also apply to the crimp quality.

2.4 Customer information

408-10389 describes the OCEAN side-feed crimping tool.

2.5 National / international standards

LV112-1	2001-01
DIN 72 551	T5/02.93 Unscreened Low Tension Cables (FLR)
DIN 72 551	T6/10.96 Unscreened Low Tension Cables (FLR)
ISO 6722-3:	1993-02 Unscreened Low Tension Cables (FL)

1. ZWECK

Diese Spezifikation beinhaltet die Richtlinien zur Verarbeitung des **AMP MCP6.3/4.8K Kontakt-systems**.

Es müssen die spezifizierten TE Crimpwerkzeuge zur Verarbeitung verwendet werden.

2. ZUSÄTZLICHE UNTERLAGEN

2.1 Kundenzeichnungen

Die Kundenzeichnung **1241438** zeigt die Maße und Werkstoffe der Kontakte. Bei eventuell auftretenden Unterschieden zwischen dem vorliegenden Dokument und der Kundenzeichnung sind die Daten, die in der Kundenzeichnung enthalten sind, vorrangig maßgebend.

2.2 Produktspezifikationen

Die elektrischen und mechanischen Eigenschaften der Kontakte sind in den Produktspezifikationen **108-18718** für die Anwendung mit Flachsteckern, sowie in **108-94427** für Anwendung mit Typ C Sicherungen (MEDIUM) beschrieben.

Diese haben im Zweifelsfall Vorrang vor den hier gemachten allgemeinen Angaben.

2.3 Verarbeitungsspezifikationen

Für die Crimpqualität gelten zusätzlich die allgemeinen Richtlinien nach Spezifikation **114-18022** und **114-18018**.

2.4 Kundenbroschüren

408-10389 beschreibt das OCEAN Side-feed Crimpwerkzeug.

2.5 Nationale / Internationale Normen

LV112-1	2001-01
DIN 72 551	T5/02.93 Ungeschirmte Niederspannungsleitungen (FLR)
DIN 72 551	T6/10.96 Ungeschirmte Niederspannungsleitungen (FLR)
ISO 6722-3:	1993-02 Ungeschirmte Niederspannungsleitungen (FL)

3. DESCRIPTION

The terms shown below are used in the specification.

3.1 Contacts with insulation crimp

3. BESCHREIBUNG

Die aufgeführten Bezeichnungen werden in der Spezifikation verwendet.

3.1 Kontakte mit Isolationscrimp

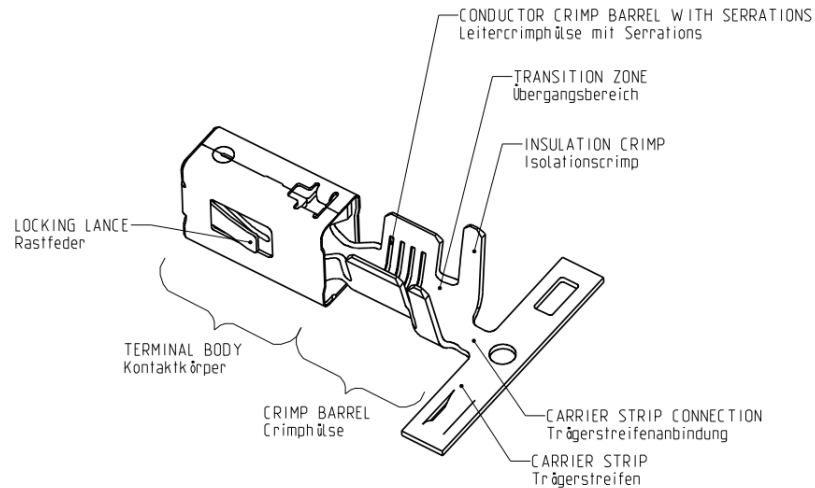

Figure 1 / Bild 1
 Uncrimped contact / ungecrimpter Kontakt

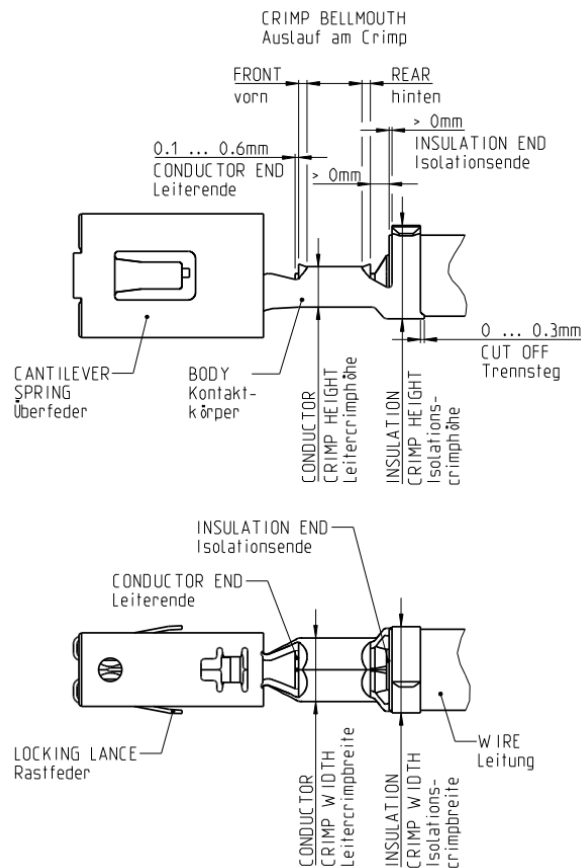

Figure 2 / Bild 2

3.2 Contacts with crimp for single wire seal

3.2 Kontakte mit Crimp für Einzelleiterdichtungen

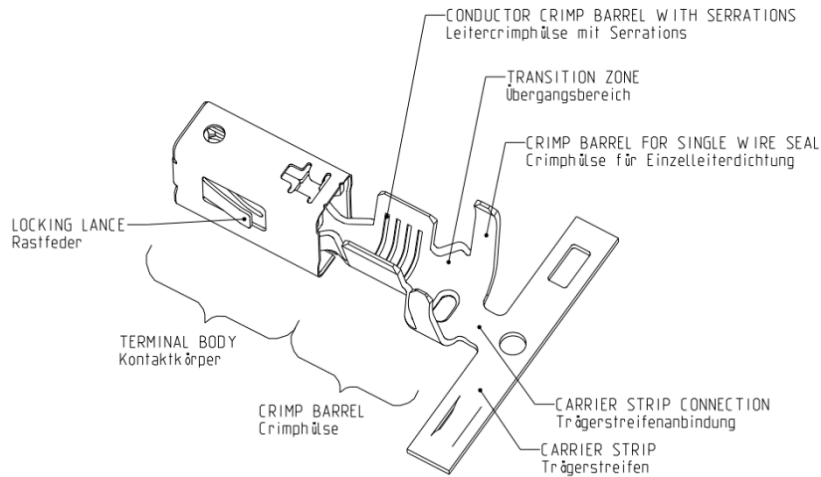

Figure 3 / Bild 3
 Uncrimped contact / ungecrimpter Kontakt

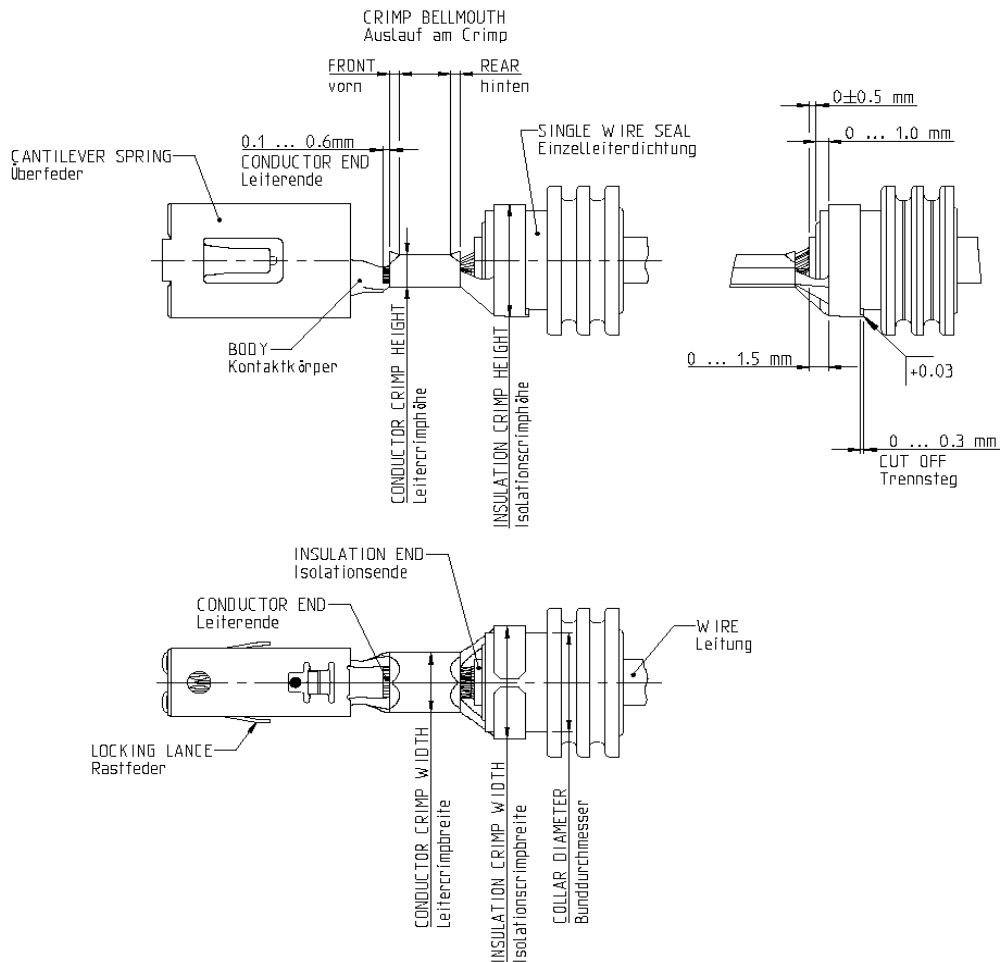

Figure 4 / Bild 4

4. REQUIREMENTS

4.1 Cables

Only FLR conductors acc. DIN 72551 part 5 and 6 or LV112-1 as well as FL conductors acc. ISO 6722-3 may be used in accordance with the data out of table 1 and 2. Other conductors require the approval of the TE engineering department. Single termination is preferred. Double termination within the conductor range is possible only with restrictions.

The cable must be stripped to the lengths shown in tables 1 and 2. Take care that the individual strands of the conductor are not bent or cut off.

For single wire seal, take care that the insulation of the cable in the sealing area is not damaged, compressed or deformed. The insulation must be clean and free of contamination.

4.2 Cut off and burr

The data acc. figure 2 and 4 are valid.

4.3 Conductor crimp

The conductor position data acc. figure 2 and 4 are valid.

In no case may the end of the insulation be crimped in the conductor crimp.

The shape, height and width of the crimp and the conductor range is shown in tables 1 and 2.

The crimp width is determined by the crimping tool and is defined as the distance between the tangent points of the two rolling radii with the vertical. The data is only a check dimension to check whether the correct tool is used. It is no quality measuring criterion.

4.4 Insulation crimp / crimp for single wire seal

The shape and width of the crimp and the insulation diameter are shown in tables 1 and 2. Due to the large tolerances of the insulation diameters, no crimp height is specified.

The position of the isolation end for contacts with insulation crimp are defined in spec. 114-18022. For single wire seal data defined in spec 114-18018 but with partly different dimensions acc. figure 4 are valid.

4. ANFORDERUNGEN

4.1 Leitung

Es dürfen nur FLR Leitungen nach DIN 72551 Teil 5 und 6 bzw. LV112-1 sowie FL Leitungen nach ISO 6722-3 nach Angabe aus Tabelle 1 und 2 verwendet werden. Andere Leitungen benötigen die Freigabe der TE Entwicklungsabteilung. Die Leitungen selbst werden vorzugsweise als Einzelanschlüsse verarbeitet. Doppelanschlüsse sind innerhalb des Drahtgrößenbereichs nur bedingt möglich.

Die Leitung wird nach den Längenangaben in Tabelle 1 und 2 abisoliert. Einzeldrähte dürfen dabei weder beschädigt noch aufgespleißt oder abgeschnitten werden. Bei Verarbeitung mit Einzeldichtungen darf die Isolation im Dichtbereich nicht beschädigt oder verformt sein. Die Oberfläche muss frei von Verunreinigungen und Rückständen sein.

4.2 Trennsteg und Grat

Es gelten die Angaben nach Bild 2 und 4.

4.3 Drahtcrimp

Für die Lage der Leiter gelten die Angaben nach Bild 2 und 4.

Das Isolationsende darf keinesfalls im Drahtcrimp eingecrimpt werden.

Die Crimpform, -höhe und -breite sowie Leiterquerschnitte sind in Tabelle 1 und 2 aufgeführt.

Die Crimpbreite ist ein werkzeuggebundenes Maß und als Abstand der Tangentenpunkte beider Einrollradien zu den Senkrechten definiert. Die Angabe ist nur ein Prüfmaß, ob das richtige Crimpwerkzeug verwendet wird. Sie ist kein Qualitätsmesskriterium.

4.4 Isolationscrimp / Crimp für Einzelleiterdichtung

Die Crimpform und die Crimpbreite sowie die Isolationsdurchmesser sind in Tabelle 1 und 2 aufgeführt. Eine Isolationscrimphöhe wird wegen der großen Toleranzen des Isolationsdurchmessers nicht vorgegeben.

Die Lage des Isolationsendes für Kontakte mit Isolationscrimp ist in der Spez. 114-18022 definiert. Für Einzelleiterdichtungen gelten die Angaben nach Spez. 114-18018, jedoch mit teils abweichenden Maßen, welche in Bild 4 definiert sind.

Qualified single wire seals are defined in table 3.

Die freigegebenen Einzelleiterdichtungen sind in Tabelle 3 definiert.

For position of single wire seals data acc. figure 4 are valid.

Für die Position der Einzelleiterdichtungen gelten die Angaben nach Bild 4.

4.5 Contact body

4.5 Kontaktkörper

Contact body, cantilever spring, locking lances as well as the transition of the crimp barrel to the contact body may neither be bent nor deformed during the crimping process.

Kontaktkörper, Überfeder, Rastfeder sowie der Übergang der Crimphülse zum Kontaktkörper dürfen durch den Crimpvorgang weder verbogen noch deformiert werden.

4.6 Shape and position tolerances of the crimped contact

4.6 Form- und Lagetoleranzen des gecrimpten Kontakts

A. Contacts with Insulation crimp

A. Kontakte mit Isolationscrimp

Referring to the symmetry of the crimp the details acc. to figure 5 are valid.

Bezüglich der Symmetrie des Crimps gelten die Angaben nach Bild 5.

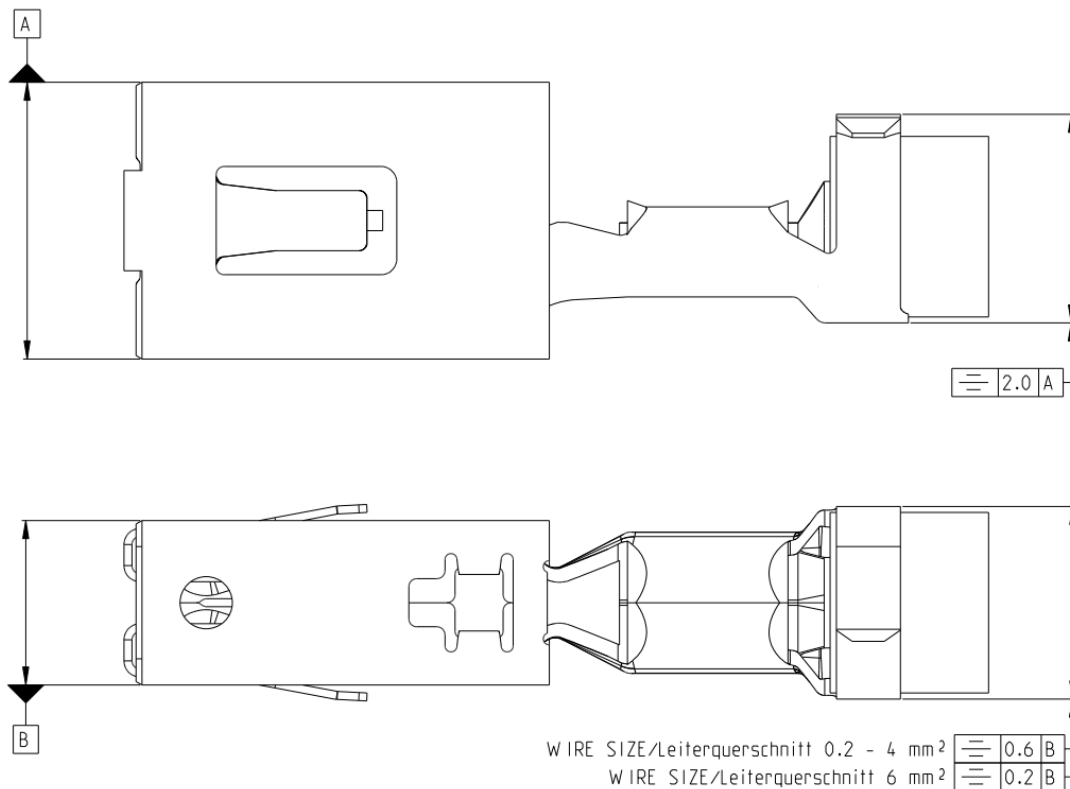

Figure 5 / Bild 5

B. Contacts with crimp for single wire seals

B. Kontakte mit Crimp für Einzelleiterdichtungen

Referring to the symmetry of the crimp the details acc. to figure 6 are valid.

Bezüglich der Symmetrie des Crimps gelten die Angaben nach Bild 6.

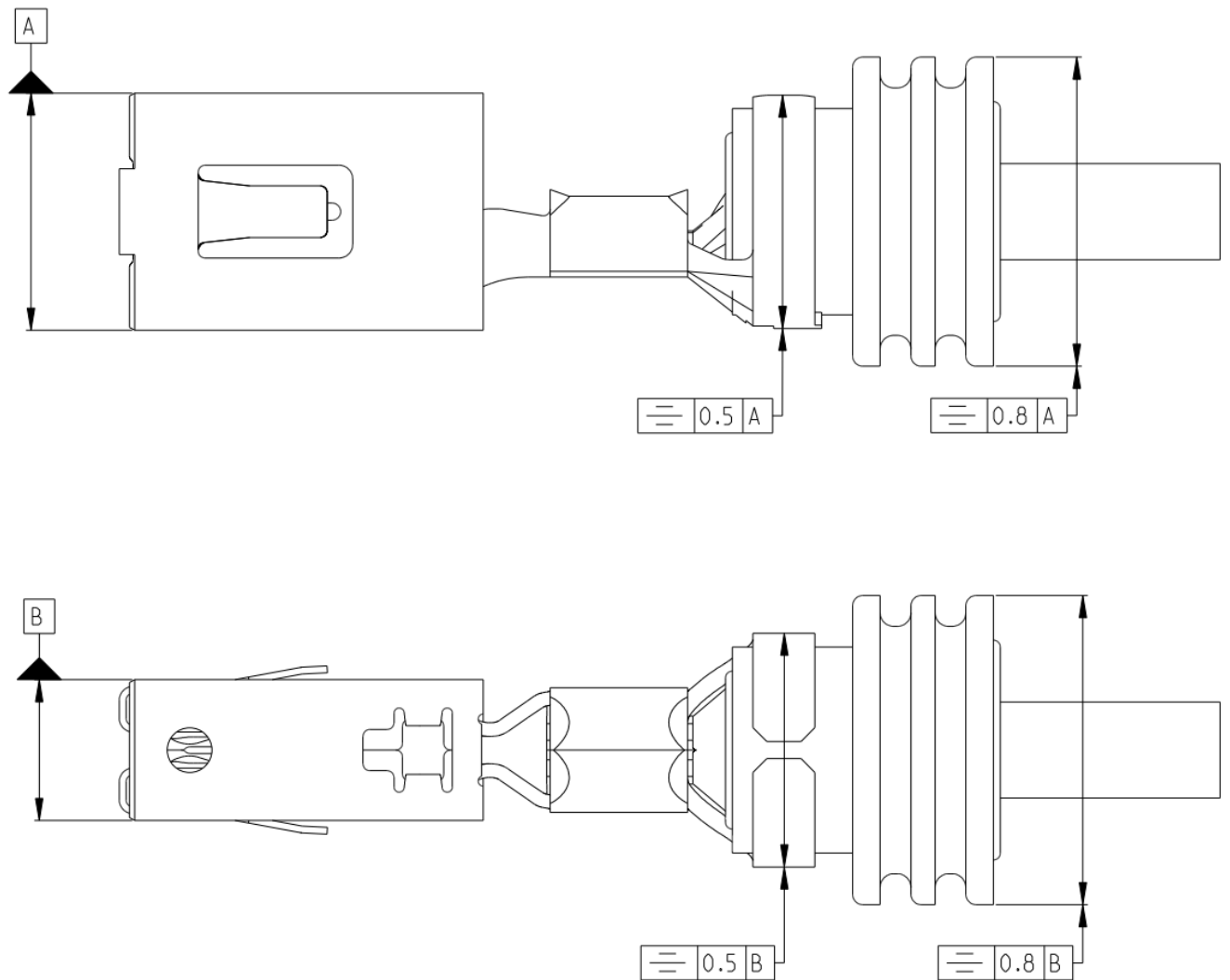

Figure 6 / Bild 6

5. CRIMPING DATA

5. CRIMPDATEN

Table 1: Contacts with insulation crimp

Tabelle 1: Kontakte mit Isolationscrimp

Order No. Bestell-Nr.		Conductor Size Range Leiterquerschnitt	Cable Type Leitungs- typ	Insulation Range Isolations- Ø [mm]	Stripped Length Abisolier- länge [mm]	Conductor Crimp Leitercrimp			Insulation Crimp Isolationscrimp		Application Tool Anschlag- werkzeug	Die for Hand Tool Matrize für Handzange Basis Hand Tool Basis Handzange 539635-1
Strip Form Bandware	Loose Piece Einzel- ware	nominal [mm ²]				Width (inch) Breite (mm) CB ₁	Height Höhe CH ₁ [mm]		Shape Form	Width (inch) Breite (mm) CB ₂		
1241400	1241401	0,22	FLR	1,1 - 1,6	3,3 +/-0,3	1,78 (.070")	1,13 +/-0,03		F	2,29 (.090")	O WRAP	x-2151200-x
		0,25					1,15 +/- 0,03					
		0,35					1,19 +/-0,03					
		0,5					1,26 +/-0,05					
1241402	1241403	0,5	FLR	1,4 - 2,1	3,8 +/-0,3	2,03 (.080")	1,43 +/-0,05		F	2,79 (.110")	OVL	x-2151190-x
2208459	---	0,75					1,52 +/-0,05	1,47 +/-0,05				
---	1,0	1,61 +/-0,05					1,54 +/-0,03					
1241404	1241405	1,5	FLR	2,2 - 3,0	4,3 +/-0,03	2,79 (.110")	1,76 +/-0,05	1,64 +/-0,05	F	3,56 (.140")	OVL	x-2151059-x
2208460	---	2,0					1,90 +/-0,05					
2333550	---	2,5					2,04 +/-0,05	1,89 +/-0,05				
1241406	1241407	3,0	FLR (FL)	3,4 - 4,4	4,8 +/-0,3	3,30 (.130")	2,13 +/-0,05		F	4,57 (.180")	OVL	x-2151070-x
2208461	---	3,5					2,24 +/-0,05					
2333551	---	4,0					2,35 +/-0,05	2,22 +/-0,05				
1241408	1241409	4,0	FLR	3,4 - 4,3	5,4 +/-0,3	4,06 (.160")	2,20 +/-0,05	2,06 +/-0,05	F	4,83 (.190")	OVL	x-2151254-x
2177995	---	6,0					2,58 +/-0,05					
2333552	---	6,0	FLR	3,4 - 4,3	5,4 +/-0,3	4,06 (.160")	2,58 +/-0,05		F	4,83 (.190")	OVL	x-2151254-x

- 1) Current standard / aktueller Standard
- 2) Preferred standard to meet new requirement @ LV214-2 Slow motion bending test / Bevorzugter Standard um den neuen Anforderungen der LV214-2 Slow Motion Prüfung zu genügen

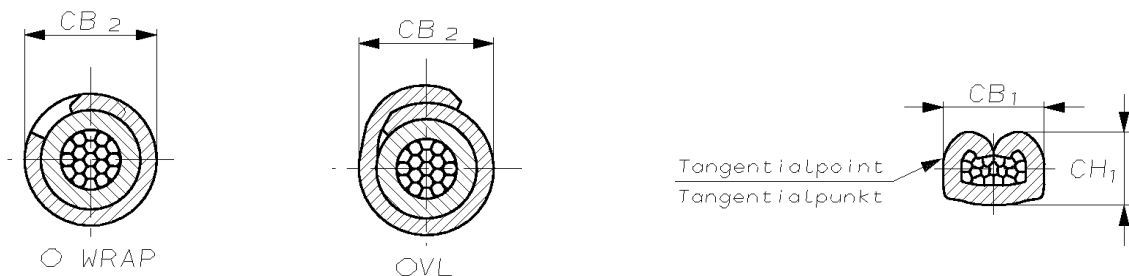

Figure 7 / Bild 7

Table 2: Contacts with crimp for single wire seal

Tabelle 2: Kontakte mit Crimp für Einzelleiterdichtung

Order No. Bestell-Nr.		Conductor Size Range Leiterquerschnitt	Cable Type Leitungs- typ	Insulation Range Isolations- Ø [mm]	Stripped Length Abisolier- länge [mm]	Conductor Crimp Drahtcrimp			Crimp for single wire seal Crimp für Einzelleiterdichtung		Application Tool Anschlag- werkzeug	Die for Hand Tool Matrize für Handzange	
Strip Form Bandware	Loose Piece Einzel- ware	nominal [mm ²]				Width (inch) Breite (mm) CB ₁	Height Höhe CH ₁ [mm]		Shape Form	Width (inch) Breite (mm) CB ₂			Shape Form
						1)	2)						
1241410	1241411	0.35 0.5	FLR (FL)	1,2 - 2,3	3,7 +/-0,3	1,78 (.070")	1,19 +/-0,03 1,26 +/-0,05		F	6,35 (.250")	O SWS	x-2151695-x	539955-2
1241412	1241413	0.5 0,75 1,0	FLR (FL)	1,4 - 2,7	4,2 +/-0,3	2,03 (.080")	1,43 +/-0,05 1,52 +/-0,05 1,47 +/-0,05 1,61 +/-0,05 1,54 +/-0,03		F	6,35 (.250")	O SWS	x-2151234-x	
1241414 2324131	1241415	1,5 2,0 2,5	FLR (FL)	2,2 - 3,7	4,7 +/-0,3	2,79 (.110")	1,76 +/-0,05 1,64 +/-0,05 1,90 +/-0,05 2,04 +/-0,05 1,89 +/-0,05		F	6,60 (.260")	O SWS	x-2151177-x	
1241416 2324132	1241417	4,0	FLR (FL)	3,4 - 4,4	5,0 +/-0,3	3,30 (.130")	2,35 +/- 0,05	2,22 +/- 0,05	F	6,86 (.270")	O SWS	x-2151151-x	
1241418 2327632	1241419	4,0 6,0	FLR	3,4 - 4,3	5,4 +/-0,3	4,06 (.160")	2,20 +/-0,05 2,06 +/-0,05 2,58 +/-0,05		F	6,86 (.270")	O SWS	x-2151466-x	3-1579021-7

- 1) Current standard / aktueller Standard
- 2) Preferred standard to meet new requirement @ LV214-2 Slow motion bending test /
 Bevorzugter Standard um den neuen Anforderungen der LV214-2 Slow Motion Prüfung zu genügen

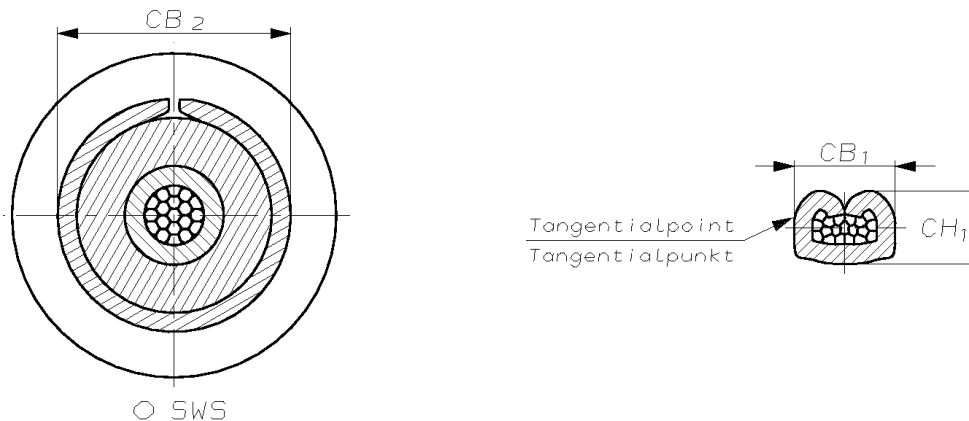

Figure 8 / Bild 8

Table 3: Single wire seals

Tabelle 3: Einzelleiterdichtungen

SINGLE WIRE SEALS / Einzelleiterdichtungen			
Bestell-Nr. / NO	ORDER	Isolations - Ø / INSULATION - Ø	Farbe / COLOUR
2177018-1		1,2-2,0	Gelb / YELLOW
1394511-1		2,0-2.7	Weiss / WHITE
1823111-1		2,7-3,0	Rotbraun / REDBROWN
1394512-1		3,4-3,7	Blau / BLUE
1719043-1		4,0-4,5	Gruen / GREEN

6. Dead end plugs assembly

Dead end plugs are available to seal cavities which are not occupied by contacts. The dead end plug is positioned in the contact cavity as shown in figure 9:

Order-No.: 967652-1

6. Montage von Blindstopfen

Zur Abdichtung von Kontaktkammern, welche nicht mit Kontakten belegt sind, stehen Blindstopfen zur Verfügung. Die Position der Blindstopfen in der Kontaktkammer wird in Bild 9 gezeigt:

Bestell Nr.: 967652-1

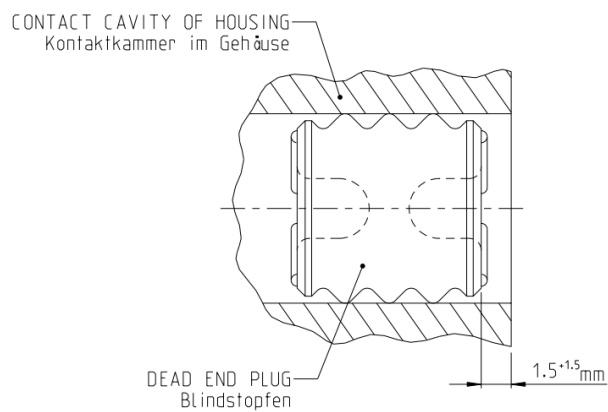

Figure 9 / Bild 9

7. AUXILIARY TOOLS

7.1 Extraction tool

To unlock the contacts from housing use extraction tool with order no. 1-1579007-3.

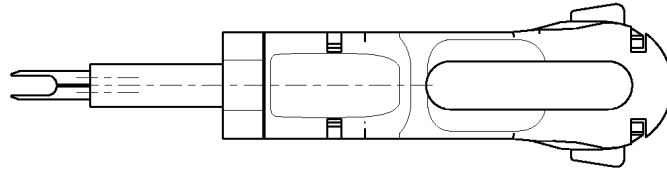

Figure 10 / Bild 10

7.2 Assembly tool

If necessary, an assembly tool can be used for insertion of contacts with single wire seals into the housings.
Order no.: 6-1579018-3

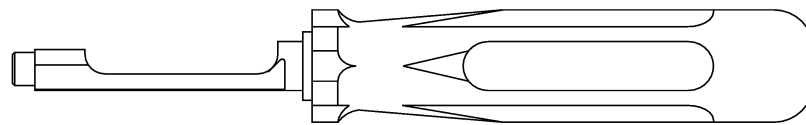

Figure 11 / Bild 11

7. HILFSWERKZEUGE

7.1 Ausdrückwerkzeug

Die Entriegelung der Kontakte aus den Gehäusen erfolgt mit dem Entriegelungswerkzeug.
Bestell - Nr. 1-1579007-3.

7.2 Montagehilfe

Zur Gehäusebestückung von Kontakten mit Einzelleiterdichtung kann im Bedarfsfall eine Montagehilfe, eingesetzt werden.
Bestell - Nr.: 6-1579018-3

<u>LTR</u>	<u>REVISION RECORD</u>	<u>DWN</u>	<u>APP</u>	<u>DATE</u>
G	New PN's added; New crimp height for SMBT added PN 1241400 (0.22mm ² and 0.35mm ²) and PN 1241410 (0.35mm ²); Crimp height change PN 1241402, PN 2208460 and PN 1241412 (1.0mm ²) to 1.54mm+/-0.03;	S. Beck	S. Spegel E. Glombitza O. Graf	29OCT2018
F	Crimp heights for SMBT added	S. Beck	S. Spegel E. Glombitza M. Jost	08MAY2017
E	Crimp heights for PN1241402/1241412 conform to previous data from Rev C; Remarks added at table 1 and 2	S. Beck	S. Spegel E. Glombitza M. Jost	19MAY2016
D	PN's 2208459, 2208460, 2208461, 2177995 added; New tables 1 and 2; new pictures 1-6; deleted all points which are define in general crimp spec. 114-18018 and 114-18022	S. Beck	S. Spegel E. Glombitza M. Jost	15APRIL2016
C	Dimension for bell mouth expand to 6mm ² wire size; OCEAN APPLICATORS added; crimp heights PN 1241408/1241418 for 4mm ² applications added; single wire seals updated	A. Mairoser		22NOV2012
B	PN 1241418 added, see table Page 10 Paragraph 8.1, Push Out test added, see page 12 and 13	R. Liebing		16OCT2006