



PNEUMATIC TURBINE VIBRATORS

MODEL GT

- Aluminium Body
- Rotary Vibrator
- Frequency / Force adjustable by air pressure
- Suitable for temperature up to 150°C
- Noise level 60—70 dBA with silencer fitted
- Force 135 N to 12000 N
- No Lubrication Required

On request can be supplied with ATEX certification
To ATEX 95 94/9/EC  II 2 G & D Zone 1, 2 & 21, 22

20 CECIL PASHLEY WAY, SHOREHAM AIRPORT, SHOREHAM, BN43 5FF, ENGLAND

Tel. +44(0) 1273 430977 Fax. +44 (0) 1273 430978

Web. www.vibtec.com E-mail. sales@vibtec.com

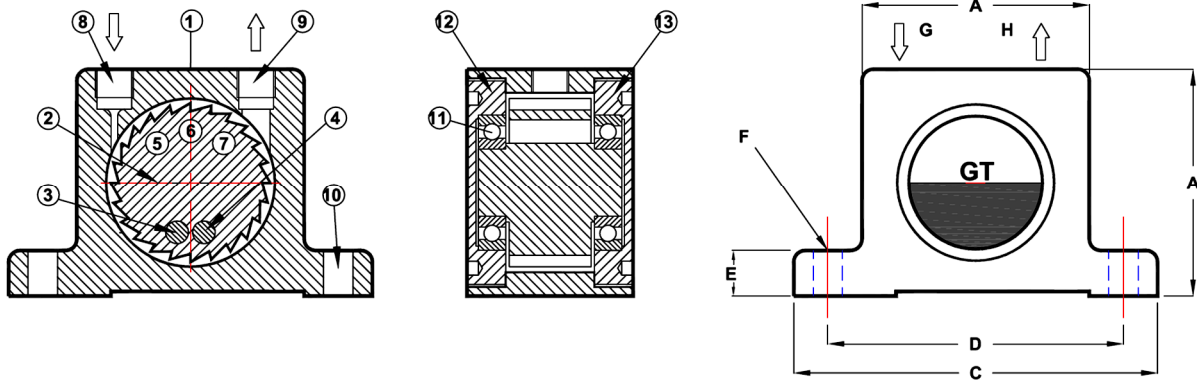

1. Extruded Aluminium Alloy Body
2. Hard Coated Aluminium Turbine Wheel
- 3/4. High Density Mass Positive Movement
- 5-7. Cavities Giving Negative Moment
8. Air Inlet
9. Air Exhaust

10. Base Mounting Holes
11. Special Pre-Lubricated Matched Sealed Bearings

Hard Coated Aluminium Endplates

12. With Left Hand Thread
13. With Right Hand Thread

PERFORMANCE DATA

Type	Frequency V.P.M.			Centrifugal Force						Air Consumption / Minute					
	2 Bar 29 PSI	4 Bar 58 PSI	6 Bar 87 PSI	2 Bar N	29 PSI lbs	4 Bar N	58 PSI lbs	6 Bar N	87 PSI lbs	2 Bar litr	29 PSI CF	4 Bar litr	58 PSI CF	6 Bar litr	87 PSI CF
GT4	14000	14430	15000	135	30	180	40	200	44	33	1.1	58	2	83	2.9
GT6	11500	12000	12500	130	29	175	39	210	47	33	1.1	58	2	83	2.9
GT8	36000	42000	46000	990	222	2060	462	2910	652	46	1.6	80	2.8	112	3.9
GT10	27500	35000	37500	840	188	1390	312	2400	538	46	1.6	80	2.8	112	3.9
GT10S	17000	23000	25000	650	146	1350	303	1950	437	46	1.6	80	2.8	112	3.9
GT13	26000	30000	33000	1400	313	2440	574	3730	836	120	4.2	200	7.0	290	10.2
GT16	17000	21500	24000	1220	274	2090	469	3160	708	120	4.2	200	7.0	290	10.2
GT16S	11500	15500	17000	1100	247	1900	426	2700	605	120	4.2	200	7.0	290	10.2
GT20	17000	20000	23000	2170	487	4040	906	5520	1238	185	6.6	325	11.4	455	15.9
GT25	12000	15500	17000	2120	475	3510	787	5070	1137	185	6.6	325	11.4	455	15.9
GT25S	8500	11000	13000	2250	504	3600	807	4900	1098	185	6.6	325	11.4	455	15.9
GT30	13000	14000	16000	3380	578	5430	1217	7540	1690	330	11.5	530	18.5	745	26.0
GT36	8000	10000	13000	3290	738	5360	1202	7190	1612	330	11.5	530	18.5	745	26.0
GT36S	6100	7200	8300	4100	919	6200	1390	7500	1681	330	11.5	530	18.5	745	26.0
GT40	7700	8800	9500	4300	964	7300	1636	9800	2197	425	15	700	24.7	970	34.2
GT48	6000	7500	9700	4900	1098	7700	1726	10500	2354	425	15	700	24.7	970	34.2
GT48S	-	5600	6300	-	-	7500	1681	12000	2691	425	15	700	24.7	970	34.2

DIMENSIONS

Type	A		B (Width)		C		D		E		F (Hole Diameter)		G/H	Weight	
	mm	inch	mm	inch	mm	inch	mm	inch	mm	inch	mm	inch	BSP	kg	lbs
GT4	40	1.57	28	1.10	70	2.75	56	2.20	10	0.39	6	0.23	1/8"	.167	.37
GT6	40	1.57	28	1.10	70	2.75	56	2.20	10	0.39	6	0.23	1/8"	.161	.35
GT8	50	1.97	33	1.30	86	3.38	68	2.68	12	0.47	7	0.27	1/8"	.255	.56
GT10	50	1.97	33	1.30	86	3.38	68	2.68	12	0.47	7	0.27	1/8"	.258	.57
GT10S	50	1.97	33	1.30	86	3.38	68	2.68	12	0.47	7	0.27	1/8"	.270	.59
GT13	65	2.56	42	1.65	113	4.45	90	3.54	16	0.63	9	0.35	1/4"	.555	1.22
GT16	65	2.56	42	1.65	113	4.45	90	3.54	16	0.63	9	0.35	1/4"	.566	1.25
GT16S	65	2.56	42	1.65	113	4.45	90	3.54	16	0.63	9	0.35	1/4"	.603	1.33
GT20	80	3.15	56	2.20	128	5.04	104	4.09	16	0.63	9	0.35	1/4"	1.076	2.37
GT25	80	3.15	56	2.20	128	5.04	104	4.09	16	0.63	9	0.35	1/4"	1.112	2.45
GT25S	80	3.15	56	2.20	128	5.04	104	4.09	16	0.63	9	0.35	1/4"	1.193	2.62
GT30	100	3.94	73	2.87	160	6.30	130	5.12	20	0.79	11	0.43	3/8"	2.201	4.84
GT36	100	3.94	73	2.87	160	6.30	130	5.12	20	0.79	11	0.43	3/8"	2.301	5.06
GT36S	100	3.94	73	2.87	160	6.30	130	5.12	20	0.79	11	0.43	3/8"	2.525	5.56
GT40	120	4.72	86	3.26	194	7.63	152	5.98	24	0.94	17	0.66	3/8"	3.696	8.13
GT48	120	4.72	86	3.26	194	7.63	152	5.98	24	0.94	17	0.66	3/8"	3.858	8.49
GT48S	120	4.72	86	3.26	194	7.63	152	5.98	24	0.94	17	0.66	3/8"	4.274	9.40

Data obtained on a heavy laboratory test block. Frequency and force will decrease on a less rigid mounting while the noise level will increase.