



Operating Parameters & Specifications

- ◆ Temperature range: 0°C - 40°C
- ◆ Response time: 0.2ms
- ◆ Input: 5VDC-24VDC
- ◆ Output: 3.3 V TTL Logic

AD-101 Air Bubble Detector

Bubble detection is critical in applications such as infusion pumps, hemodialysis and blood flow monitoring. TE Connectivity (TE) has developed a new compact AD-101 Air Bubble Detector (ABD) for non-invasive continuous monitoring of fluid for air bubble detection. Using ultrasonic technology the AD-101 sensor is capable of positively identifying the presence of a break in flow of any type of liquid.

Features

- ◆ Detects bubble size as small as 70% of tubing inner diameter
- ◆ Sensor can be customized to fit tube or pipe
- ◆ Tubing size from 3 mm to 10 mm
- ◆ Non-invasive design eliminates sterility and fluid compatibility concerns
- ◆ High noise immunity to EMI/RFI
- ◆ Acoustic coupling agent not required
- ◆ Integral electronics
- ◆ Power-on and continuous self-diagnostic tests to confirm functionality

Applications

- ◆ Infusion Pump
- ◆ Hemodialysis
- ◆ Apheresis/Auto-transfusion
- ◆ IN-VIVO Detection of Gas
- ◆ Biotech/DNA Analysis
- ◆ Hydroponics
- ◆ Blood Processing
- ◆ Smart Farming
- ◆ Immunoassay
- ◆ Food Processing
- ◆ Chemical Analysis

AD-101

Air Bubble Detector

Dimensions

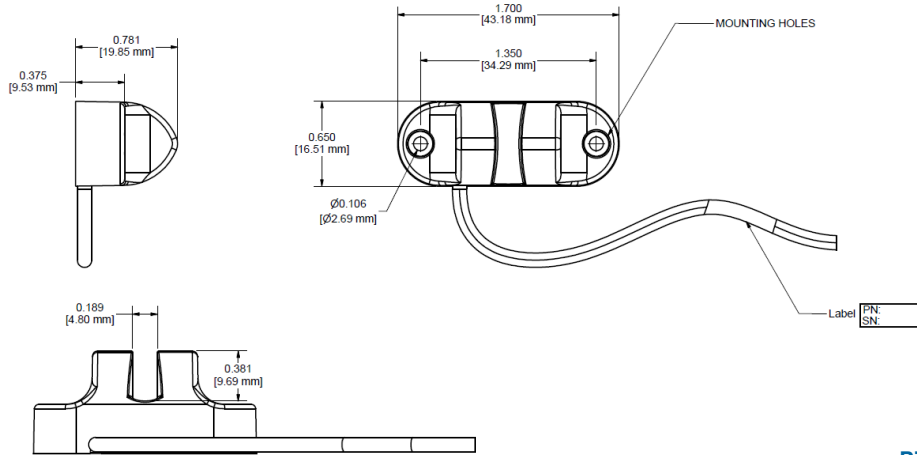

Schematic

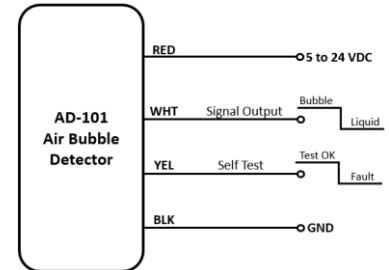

Specifications

Input	Red = 5 – 24 VDC Black = GND
Sensor Output	White = Output 3.3V TTL, Low When Liquid Present, High When Bubble Present
Self-Test Output	Yellow = Self-test output, 3.3V TTL, High When Pass, Low When Fault
Response Time	0.22 Milliseconds
Temp. Range	0 to 40°C
Bubble Size	Smallest bubble detected =70% of tubing I.D.
Material	ABS/PC (55/45) Plastic Blend, Injection Molded Parts, UL 94 V-2 Rated
Cable	4 Conductor 28AWG, 350mm Long UL Style Number 2725
Electronics	Integral

Pin Out

Pin	Color	Function
1	Black	GND
2	White	Output
3	Yellow	Self-test
4	Red	5 - 24 VDC

Part Number

Part Number	Description
071-06403	AD-101 compact ABD assembly 4MM
071-06402	AD-101 compact ABD assembly 6MM

NORTH AMERICA

Measurement Specialties, Inc.,
a TE Connectivity Company
Tel 800-522-06752 (option 2)
customercare.hmpt@te.com

EUROPE

Measurement Specialties, (Europe) Ltd.,
a TE Connectivity Company
Tel +31-73-624-6999
customercare.dtmtd@te.com

ASIA

Measurement Specialties (China), Ltd.,
a TE Connectivity Company
Tel 400-820-6049
customercare.shzn@te.com

TE.com/sensorsolutions

TE Connectivity, TE connectivity (logo), and Measurement Specialties are trademarks. All other logos, products and/or company names referred to herein might be trademarks of their respective owners.

The information given herein, including drawings, illustrations and schematics which are intended for illustration purposes only, is believed to be reliable. However, TE Connectivity makes no warranties as to its accuracy or completeness and disclaims any liability in connection with its use. TE Connectivity's obligations shall only be as set forth in TE Connectivity's Standard Terms and Conditions of Sale for this product and in no case will TE Connectivity be liable for any incidental, indirect or consequential damages arising out of the sale, resale, use or misuse of the product. Users of TE Connectivity products should make their own evaluation to determine the suitability of each such product for the specific application.

© 2017 TE Connectivity. All Rights Reserved.