

Long-Life DC Tubular Solenoid



Model LT12x13

Features:

- Long life construction
- Plunger stop for quiet operation
- DC solenoid applications only
- UL recognized
- Stainless steel guide tube
- Teflon coated plunger



Electrical:

- Coil Voltages: 6, 12, 24, 48, 110 VDC standard
- Coil Termination: 6.5" Wire leads
22 AWG (standard)
- Duty Cycle: 100% Continuous, 25% Intermittent,
10% Intermittent, 1% Pulse
- Coil treatment: Tape Wrapped
- Insulation Class: Class A Rating - 105°C (221°F)
- Dielectric Strength: 1500V 60 Hz

Mechanical:

- Size: 1.63" (L) x 1.5" (D)
- Plunger Diameter: 0.5"
- Plunger Guide Material: Stainless Steel
- Mounting: Hex Nut
- Weight: Plunger 1.8 oz, Total 10.6 oz
- Life Expectancy: 10 Million Cycles¹

¹ - Dependent on load conditions

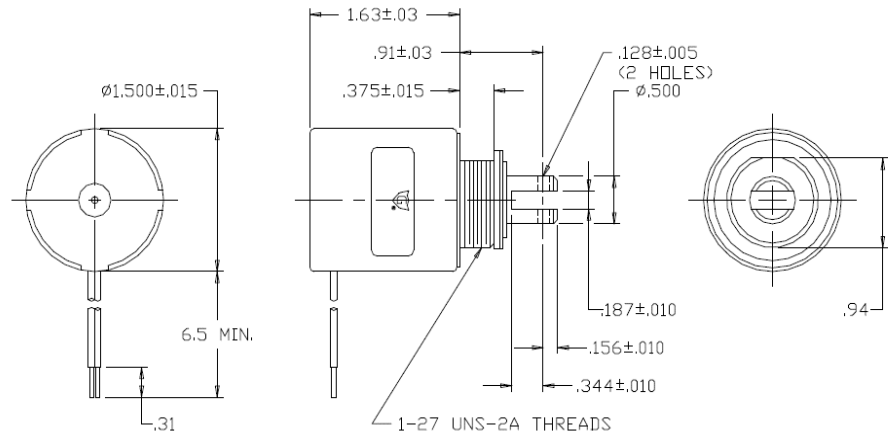

Standard Part Numbers

Model No.	Part No.	Duty Cycle	Voltage	Resistance ² (Ω)	Power (W)	Current
LT12x13-C-12D	A420-064858-00	Cont.	12VDC	18.3	8.3	656 mA
LT12x13-I-12D	A420-064859-00	Inter.	12VDC	5.9	25.6	2.03 A
LT12x13-C-24D	A420-064860-00	Cont.	24VDC	71.2	8.5	337 mA
LT12x13-I-24D	A420-064861-00	Inter.	24VDC	22	27.5	1.09 A

² - Coil resistance tolerance +/- 5%

Contact us for custom voltages or duty cycles

Solenoid shown energized with plunger fully seated
Supplied with mounting bracket, hex nut and lock washer shipped loose

Available Customization:

- Plunger
- Lead and Connector
- DC Voltage
- Duty Cycle
- Insulation systems up to class H 180° C (356° F)
* Minimum quantities apply

Stroke (in.)	Typical Pull Force Ounces [N] @ 20°C (68°F) (Distance from fully seated position)								HOLDING FORCE Ounces [N]	Power (W)
	0.050	0.125	0.250	0.375	0.500	0.625	0.750			
Continuous 100%	90 [25]	45 [12.5]	20 [5.6]	15 [4.2]	5 [1.4]	3 [0.8]	1.5 [0.4]	100 [27.8]	8.3	
Intermittent 25%	160 [44.5]	118 [32.8]	67 [18.6]	40 [11.1]	20 [5.6]	10 [2.8]	7 [1.9]	144 [40]	26	
Intermittent 10% ³	221 [61.4]	185 [51.4]	143 [39.8]	107 [29.7]	94 [26.1]	45 [12.5]	25 [7]	387 [107.6]	78.5	
Pulse 1% ³	275 [76.5]	250 [69.5]	210 [58.4]	165 [45.9]	115 [32.]	75 [20.9]	48 [13.3]	N/A	156.1	

Continuous Duty 100% = 100% On Time
Intermittent Duty 25% = 25% On Time (100 Seconds On Max Followed By 300 Seconds Off)
Intermittent Duty 10% = 90% On Time (10 Seconds On Max Followed By 90 Seconds Off)
Pulse Duty 1% = 99% On Time (1 Second On Max Followed By 99 Seconds Off)

³ - Calculated force values to be verified in application

Optional Return Spring Kit

A490-367460-19



GUARDIAN-ELECTRIC.COM

1425 Lake Ave - Woodstock IL 60098 - Phone: 800-762-0369
The information is subject to change without notice. © Guardian Electric

